



Price | 20  
List | 25

**W**  
**WEBERT**

Made in Italy with Passion

#Think  
DIFFERENT

## ITALIAN CONCEPT, DESIGN AND MANUFACTURE

La nostra storia ruota intorno alla passione. Innanzi tutto quella che in Webert mettiamo nel nostro lavoro di squadra, che consiste nel creare linee che esprimono eleganza, dando spazio ad un design giovane, moderno ed emergente. Ma la passione per ciò che realizziamo ci porta anche a nutrire un assoluto rispetto per chi sceglie i nostri prodotti. Ai quali il nostro cliente chiede raffinatezza, affidabilità, funzionalità e il giusto rapporto tra ciò che acquista e ciò che spende. È dal 1975 che questi valori ci guidano. Hanno fatto di Webert un'azienda che, nell'arredobagno italiano, significa innovazione, qualità e rigore. Sono le caratteristiche che ritrovate anche oggi nella nuova gamma di prodotti presentata in queste pagine.

.....

The history of Webert revolves around passion. Primarily the passion that we put into our teamwork, which involves creating lines that embody elegance while giving space to young, modern and emerging designs. This passion for our creations goes hand-in-hand with total respect for the people who choose our products. Our customers want refinement, reliability, functionality and value for money. These have been our guiding values since 1975. These values have turned Webert into an Italian hallmark for innovation, quality and precision. These are the values you can still find all these admirable qualities today in our new range of products.



Hotel Melodia del Bosco  
Badia, Italy



Lusail Stadium  
Lusail, Qatar



Aquagrand  
Lindos, Greece



Govone 33  
Milan, Italy



Hampton  
Quinto, Ecuador



Entre Hôtes  
La Rochelle, France



# Primavera

COLLEZIONE



.260  
BLU NOTTE



.215  
TURCHESE

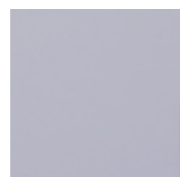

.220  
GLICINE



.225  
CIPRIA



.230  
TORTORA



.235  
BORGOGNA



.240  
OCRA



.255  
SMERALDO



.245  
ACQUAMARINA



.250  
LIME



.330  
ARDESIA



.355  
NICKEL



.340  
TERRA DI SIENA



.370  
PORPORA



.400  
ARANCIONE



.385  
COBALTO



.380  
VERDE GIADA



.335  
CELESTE



.365  
PERLA ROSA



.320  
ROSA ANTICO



.390  
ORO SCURO



.360  
ORO CHIARO

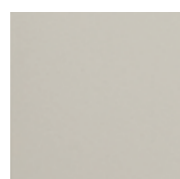

.325  
CHAMPAGNE



.395  
ARGENTO



.375  
SATINATO

## Matt COLORS

# COLOR Lab



.263  
NERO / BLU NOTTE



.218  
NERO / TURCHESE



.223  
NERO / GLICINE



.228  
NERO / CIPRIA



.230  
NERO / TORTORA



.238  
NERO / BORGOGNA



.243  
NERO / OCRA



.258  
NERO / SMERALDO



.248  
NERO / ACQUAMARINA



.253  
NERO / LIME

## Met COLORS



# Finishings

## FINITURE \_ FINISHINGS

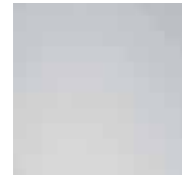

**.015**  
CROMO / CHROME  
CHROMÉ / VERCHROMT  
CROMO

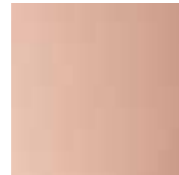

**.980**  
ORO ROSA / ROSE GOLD  
OR ROSE / ROSE GOLD  
ORO ROSA



**.010**  
ORO / GOLD  
DORÉ / GOLD  
ORO



**.017**  
CROMO-ORO / CHROME-GOLD  
CHROMÉ-OR / CHROM-GOLD  
CROMO-ORO



**.345**  
ACCIAIO SPAZZOLATO  
BRUSHED NICKEL  
ACIER BROSSÉ  
EDELSTAHL OPTIK  
ACERO CEPILLADO



**.065**  
BRONZATO / BRONZE  
BRONZE / BRONZE  
BRONZE



**.560**  
NERO OPACO  
MATT BLACK  
NOIR MAT  
MATT SCHWARZ  
NEGRO MATE

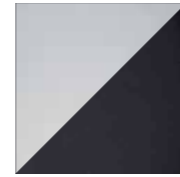

**.564**  
NERO OPACO-CROMO  
MATT BLACK-CHROME  
NOIR MAT-CHROMÉ  
MATT SCHWARZ-CHROM  
NEGRO MATE-CROMADO



**.441**  
ACCIAIO + NERO  
STEEL + BLACK  
ACIER + NOIR  
STAHL + SCHWARZ  
ACERO+ NEGRO



**.741**  
ACCIAIO + BIANCO  
STEEL + WHITE  
ACIER + BLANC  
STAHL + WEISS  
ACERO + BLANCO



**.740**  
BIANCO OPACO  
MATT WHITE  
BLANC MAT  
MATT WEISS  
BLANCO MATE



**.844**  
BIANCO LUCIDO-CROMO  
SHINY WHITE-CHROME  
BLANC BRILLANT-CHROMÉ  
GLÄNZEND WEISS-CHROM  
BLANCO BRILLANTE-CROMADO



**.440**  
ACCIAIO INOX  
STAINLESS STEEL  
ACIER INOX  
EDELSTAHL  
ACERO



**.722**  
NERO OPACO + RAME PVD  
MATT BLACK + COPPER PVD  
NOIR MAT + CUIVRE PVD  
MATT SCHWARZ + KUPFER PVD  
NEGRO MATE + COBRE PVD



**.723**  
NERO OPACO + ORO PVD  
MATT BLACK + GOLD PVD  
NOIR MAT + OR PVD  
MATT SCHWARZ + GOLD PVD  
NEGRO MATE + ORO PVD

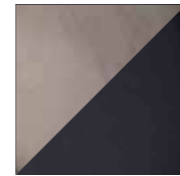

**.724**  
NERO OPACO + ANTRACITE PVD  
MATT BLACK + ANTRACITE PVD  
NOIR MAT + ANTRACITE PVD  
MATT SCHWARZ + ANTHRAZIT PVD  
NEGRO MATE + ANTRACITA PVD



**.081**  
TALCO



**.082**  
POMICE



**.083**  
BRINA



**.084**  
ARENARIA



**.085**  
CACAO



**.086**  
BASALTO

## LEGENDA

AC	Accessori	EN	Essential	OM	Omega
AI	Aria	EP	Elio Slim	ON	One-A
AA	Azeta New	HB	Habitat	OR	Ombra
AM	Armony	IB	Ibiza	OT	Ottocento
AZ	Azeta	KA	Karenina	OX	One-x
BA	Baltimora	KE	Keo	PR	Praga
BY	Byblos	KI	Kimono	SN	Springy
CN	Conic	LM	Lima	SP	Semplice
CO	Coral	LO	London	SX	Sax
DA	Dado	LS	Lisbona	SY	Sidney
DD	Diadema	LV	Living	VA	Valentino
DH	Doha	MT	Malta	VP	Viper
DO	Dorian	NB	One-B	WO	Wolo
DR	Doremi	OA	Opera	WD	Window
EA	Elio Steel	OB	Oblique	YN	Yen
EL	Elio	OE	Opera Moderna		

## VARIANTI / VERSIONS / VERSIONS / VARIANTEN / VARIANTES



Articolo con flessibile con attacco da 1/2".  
Item with 1/2" flex. hose.  
Article avec flexible 1/2".  
Artikel mit flex. Anschlussschlauch 1/2".  
Artículo con tubo flexible, unión de 1/2".



Peso confezione singola.  
Single package weight.  
Poids de chaque pièce.  
Einzelstück Gewicht.  
Peso caja individual.



Quantità pezzi per box.  
Pieces for box.  
Pièces par boîte.  
Stuecken pro Schachtel.  
Piezas por caja.



Aeratore.  
Aerator.  
Aérateur.  
Mischdüse.  
Aireador.



Chiave per ghiera serraggio cartuccia.  
Key for cartridge sealing nut.  
Clé pour écrou de serrage cartouche.  
Kartuscheandruckhuelse.  
Llave para virola fijación cartucho.



Flessibile attacco muro.  
Wall flexible hose.  
Flexible d'alimentation.  
Anschlussschlauch.  
Tubo flexible de acero.



Articolo con eccentrici interasse fisso 153 mm.  
Item with 153 mm connections.  
Article avec raccords à rosace 153 mm.  
Artikel mit verdeckten Anschlüssen 153 mm Abstand.  
Artículo con excéntricos, distancia entre los ejes fija 153 mm.

# Index



Diadema	12
Elio Slim	22
Elio Steel	34
Ombr	46
Ombr Plus	62
One-X	76
One-B	86
One-A	94
Essential	96
Aria	98
Coral	110
Opera	120
Opera Moderna	134
Living	142
Wolo	154
Elio	164
Azeta New	180
Pegaso	186
Doremi	196
Kimono	210
Ottocento	216
Karenina	228
Dorian	240
Accessori bagno	250
Easy Bathroom	260
Shower set	300
Kitchen	332
Accessories & Spare parts	352

DIADEMA

CUSTOMIZATION

ELE

STYLE



GAN

CE

SINOUSITY





CROMO  
CHROME

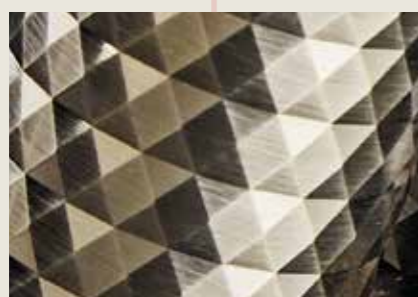

ACCIAIO  
STEEL



GRAFITE  
GRAPHITE



CROMO NERO  
BLACK CHROME



NERO OPACO  
MATT BLACK



LEVE DISPONIBILI  
AVAILABLE LEVERS



Le leve in 5 finiture sono disponibili per tutti i prodotti della serie.  
Levers in 5 finishes are available for all products in the series.



## DD830101

Kg 1,3  
Box pcs 5



Miscelatore lavabo, scarico click-clack spessore regolabile, flex antitorsione cm 50 3/8" F.

One hole basin mixer, click-clack waste, antitorsion flex cm 50 3/8" F.

Mitigeur lavabo, vidage click-clack, flexibles antitorsion cm 50 3/8" F.

Einhebelmischer Waschtischbatterie mit up & down Ablaufgarnitur, mit flex. Anschlussschläuchen cm 50 3/8" F.

Monomando para lavabo con valvula click-clack, tubo flexible inoxidable de 50 cm, empalme 3/8" F.

Corpo cromo / Chrome body	.015	Leva cromo / Chrome lever	€ 198,00
	.587	Leva Nero opaco / Matt black lever	€ 198,00
	.588	Leva Simil acciaio / Steel lever	€ 198,00
	.589	Leva Cromo nero / Black chrome lever	€ 198,00
	.590	Leva Grafite / Graphite lever	€ 198,00

Corpo Nero opaco / Matt black body	.591	Leva cromo / Chrome lever	€ 238,00
	.560	Leva Nero opaco / Matt black lever	€ 238,00
	.592	Leva Simil acciaio / Steel lever	€ 238,00
	.593	Leva Cromo nero / Black chrome lever	€ 238,00
	.594	Leva Grafite / Graphite lever	€ 238,00

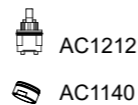
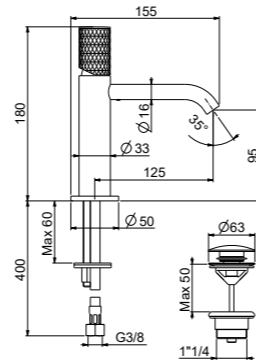

DD830102

## DD833101

Kg 1,5  
Box pcs 5



Miscelatore lavabo medio, scarico click-clack spessore regolabile, flex antitorsione cm 50 3/8" F.

One hole medium basin mixer, click-clack waste, antitorsion flex cm 50 3/8" F.

Mitigeur lavabo, vidage click-clack, flexibles antitorsion cm 50 3/8" F.

Einhebelmischer Waschtischbatterie mit up & down Ablaufgarnitur, mit flex. Anschlussschläuchen cm 50 3/8" F.

Monomando para lavabo con valvula click-clack, tubo flexible inoxidable de 50 cm, empalme 3/8" F.

Corpo cromo / Chrome body	.015	Leva cromo / Chrome lever	€ 213,00
	.587	Leva Nero opaco / Matt black lever	€ 213,00
	.588	Leva Simil acciaio / Steel lever	€ 213,00
	.589	Leva Cromo nero / Black chrome lever	€ 213,00
	.590	Leva Grafite / Graphite lever	€ 213,00

Corpo Nero opaco / Matt black body	.591	Leva cromo / Chrome lever	€ 256,00
	.560	Leva Nero opaco / Matt black lever	€ 256,00
	.592	Leva Simil acciaio / Steel lever	€ 256,00
	.593	Leva Cromo nero / Black chrome lever	€ 256,00
	.594	Leva Grafite / Graphite lever	€ 256,00

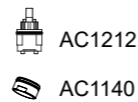
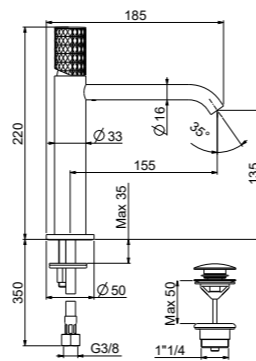

DD833102

## DD830401

Kg 2  
Box pcs 5



Miscelatore lavabo alto, scarico click-clack spessore regolabile, flex antitorsione cm 70 3/8" F.

One hole high basin mixer, click-clack waste, antitorsion flex cm 70 3/8" F.

Mitigeur lavabo haut, vidage click-clack, flexibles antitorsion cm 70 3/8" F.

Einhebelmischer Waschtischbatterie, mit hoher Ausführung, mit up & down Ablaufgarnitur, mit Flex. Anschlussschläuchen cm 70 3/8" F.

Monomando para lavabo alto con valvula click-clack, tubo flexible inoxidable de 70 cm, empalme 3/8" F.

Corpo cromo / Chrome body	.015	Leva cromo / Chrome lever	€ 222,00
	.587	Leva Nero opaco / Matt black lever	€ 222,00
	.588	Leva Simil acciaio / Steel lever	€ 222,00
	.589	Leva Cromo nero / Black chrome lever	€ 222,00
	.590	Leva Grafite / Graphite lever	€ 222,00

Corpo Nero opaco / Matt black body	.591	Leva cromo / Chrome lever	€ 266,00
	.560	Leva Nero opaco / Matt black lever	€ 266,00
	.592	Leva Simil acciaio / Steel lever	€ 266,00
	.593	Leva Cromo nero / Black chrome lever	€ 266,00
	.594	Leva Grafite / Graphite lever	€ 266,00

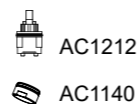
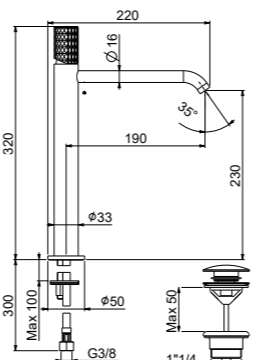

DD830402

## DD840101

Kg 1,3  
Box pcs 5



Miscelatore bidet, scarico click-clack spessore regolabile, flex antitorsione cm 50 3/8" F.

One hole bidet mixer, click-clack waste, antitorsion flex cm 50 3/8" F.

Mitigeur bidet, vidage click-clack, flexibles antitorsion cm 50 3/8" F.

Einhebelmischer Bidetbatterie mit up & down Ablaufgarnitur 1" 1/4, mit flex. Anschlussschläuchen cm 50 3/8" F.

Monomando para bidé con desagüe up & down, tubo flexible inoxidable de 50 cm, empalme 3/8" F.

Corpo cromo / Chrome body	.015	Leva cromo / Chrome lever	€ 198,00
	.587	Leva Nero opaco / Matt black lever	€ 198,00
	.588	Leva Simil acciaio / Steel lever	€ 198,00
	.589	Leva Cromo nero / Black chrome lever	€ 198,00
	.590	Leva Grafite / Graphite lever	€ 198,00

Corpo Nero opaco / Matt black body	.591	Leva cromo / Chrome lever	€ 238,00
	.560	Leva Nero opaco / Matt black lever	€ 238,00
	.592	Leva Simil acciaio / Steel lever	€ 238,00
	.593	Leva Cromo nero / Black chrome lever	€ 238,00
	.594	Leva Grafite / Graphite lever	€ 238,00

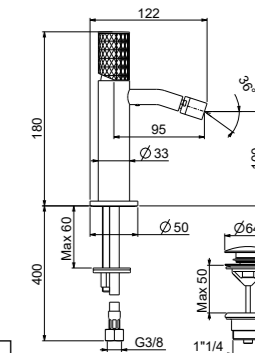

DD840102

## DD830606

Kg 2,1  
Box pcs 12



Miscelatore monocomando per lavabo incasso muro, con piastra orizzontale, senza scarico e flessibili.

Concealed single lever washbasin mixer, horizontal cover plate, without pop-up waste and flex hoses.

Mitigeur de lavabo à encastrer, rosace horizontale, sans vidage et flexibles.

Einhebelmischer Unterputz-Waschtischbatterie waagerechte Rosette, ohne Ablaufgarnitur und flex. Anschlussschläuchen.

Monomando empotrable para lavabo, de pared, con placa horizontal, sin desagüe ni tubos flexibles.

Corpo cromo / Chrome body	.015	Leva cromo / Chrome lever	€ 159,00
	.587	Leva Nero opaco / Matt black lever	€ 159,00
	.588	Leva Simil acciaio / Steel lever	€ 159,00
	.589	Leva Cromo nero / Black chrome lever	€ 159,00
	.590	Leva Grafite / Graphite lever	€ 159,00

Corpo Nero opaco / Matt black body	.591	Leva cromo / Chrome lever	€ 223,00
	.560	Leva Nero opaco / Matt black lever	€ 223,00
	.592	Leva Simil acciaio / Steel lever	€ 223,00
	.593	Leva Cromo nero / Black chrome lever	€ 223,00
	.594	Leva Grafite / Graphite lever	€ 223,00

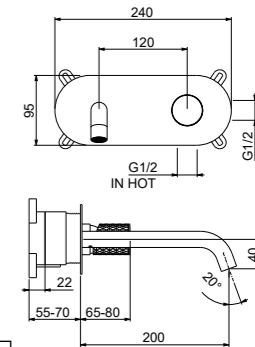

PER FINITURE CONSULTARE SEZIONE EASY BATHROOM A PAG. 260  
.....  
FOR ALL AVAILABLE FINISHINGS PLEASE GO TO EASY BATHROOM P. 260

## DD830609

Kg 2,1  
Box pcs 12



Miscelatore monocomando per lavabo incasso muro, con piastre separate, senza scarico e flessibili.

Concealed single lever washbasin mixer, with 2 plates, without pop-up waste and flex hoses.

Mitigeur de lavabo à encastrer, avec 2 rosaces, sans vidage et flexibles.

Einhebelmischer Unterputz-Waschtischbatterie, mit getrennten Platten, ohne Ablaufgarnitur und flex. Anschlussschläuchen.

Monomando empotrable para lavabo de pared, con 2 placas, sin desagüe ni tubos flexibles.

Corpo cromo / Chrome body	.015	Leva cromo / Chrome lever	€ 156,00
	.587	Leva Nero opaco / Matt black lever	€ 156,00
	.588	Leva Simil acciaio / Steel lever	€ 156,00
	.589	Leva Cromo nero / Black chrome lever	€ 156,00
	.590	Leva Grafite / Graphite lever	€ 156,00

Corpo Nero opaco / Matt black body	.591	Leva cromo / Chrome lever	€ 218,00
	.560	Leva Nero opaco / Matt black lever	€ 218,00
	.592	Leva Simil acciaio / Steel lever	€ 218,00
	.593	Leva Cromo nero / Black chrome lever	€ 218,00
	.594	Leva Grafite / Graphite lever	€ 218,00

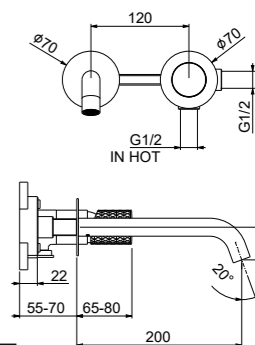

PER FINITURE CONSULTARE SEZIONE EASY BATHROOM A PAG. 260  
.....  
FOR ALL AVAILABLE FINISHINGS PLEASE GO TO EASY BATHROOM P. 260

## DD880101

 Kg 1,1

Miscelatore monocomando per doccia incasso, con piastra, senza flessibile, doccetta e gancio.

Concealed single lever shower mixer with cover plate, without shower set.

Mitigeur de douche à encastrer avec rosace, sans garniture de douche.

Einhebelmischer Unterputz-Brausebatterie, mit Rosette ohne Brausegarnitur.

Monomando empotrable para ducha, con placa, sin tubo flexible, ducha ni gancho.

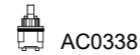
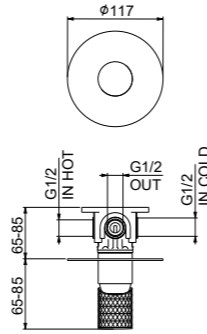

Corpo cromo / Chrome body	.015	Leva cromo / Chrome lever	€ 82,00
	.587	Leva Nero opaco / Matt black lever	€ 82,00
	.588	Leva Simil acciaio / Steel lever	€ 82,00
	.589	Leva Cromo nero / Black chrome lever	€ 82,00
	.590	Leva Grafite / Graphite lever	€ 82,00

Corpo Nero opaco / Matt black body	.591	Leva cromo / Chrome lever	€ 115,00
	.560	Leva Nero opaco / Matt black lever	€ 115,00
	.592	Leva Simil acciaio / Steel lever	€ 115,00
	.593	Leva Cromo nero / Black chrome lever	€ 115,00
	.594	Leva Grafite / Graphite lever	€ 115,00

PER FINITURE CONSULTARE SEZIONE EASY BATHROOM A PAG. 260

FOR ALL AVAILABLE FINISHINGS PLEASE GO TO EASY BATHROOM P. 260

## DD860901

 Kg 3,2

Miscelatore doccia incasso con deviatore ceramico, due uscite.

2-way built-in shower mixer with ceramic diverter.

Mitigeur douche à encastrer avec inverseur en céramique, deux sorties.

2-Weg Unterputz Duschenmischer mit Keramikumsteller.

Mezclador ducha empotrable con desviador cerámico, dos vías.

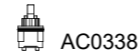
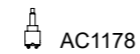
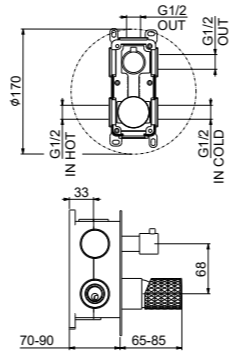

Corpo cromo / Chrome body	.015	Leva cromo / Chrome lever	€ 130,00
	.587	Leva Nero opaco / Matt black lever	€ 130,00
	.588	Leva Simil acciaio / Steel lever	€ 130,00
	.589	Leva Cromo nero / Black chrome lever	€ 130,00
	.590	Leva Grafite / Graphite lever	€ 130,00

Corpo Nero opaco / Matt black body	.591	Leva cromo / Chrome lever	€ 182,00
	.560	Leva Nero opaco / Matt black lever	€ 182,00
	.592	Leva Simil acciaio / Steel lever	€ 182,00
	.593	Leva Cromo nero / Black chrome lever	€ 182,00
	.594	Leva Grafite / Graphite lever	€ 182,00

PER FINITURE CONSULTARE SEZIONE EASY BATHROOM A PAG. 260

FOR ALL AVAILABLE FINISHINGS PLEASE GO TO EASY BATHROOM P. 260

## DD880601

 Kg 3,5

Miscelatore doccia incasso con deviatore ceramico, tre uscite.

3-way built-in shower mixer with ceramic diverter.

Mitigeur douche à encastrer avec inverseur en céramique, trois sorties.

3-Weg Unterputz Duschenmischer mit Keramikumsteller.

Mezclador ducha empotrable con desviador cerámico, tres vías.

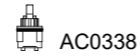
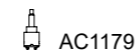
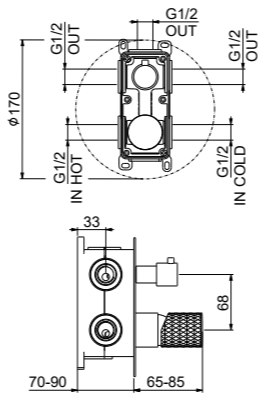

Corpo cromo / Chrome body	.015	Leva cromo / Chrome lever	€ 207,00
	.587	Leva Nero opaco / Matt black lever	€ 207,00
	.588	Leva Simil acciaio / Steel lever	€ 207,00
	.589	Leva Cromo nero / Black chrome lever	€ 207,00
	.590	Leva Grafite / Graphite lever	€ 207,00

Corpo Nero opaco / Matt black body	.591	Leva cromo / Chrome lever	€ 290,00
	.560	Leva Nero opaco / Matt black lever	€ 290,00
	.592	Leva Simil acciaio / Steel lever	€ 290,00
	.593	Leva Cromo nero / Black chrome lever	€ 290,00
	.594	Leva Grafite / Graphite lever	€ 290,00

PER FINITURE CONSULTARE SEZIONE EASY BATHROOM A PAG. 260

FOR ALL AVAILABLE FINISHINGS PLEASE GO TO EASY BATHROOM P. 260

MINIMAL





ELIO  
SLIM

— MET.





PORTA SALVIETTA / TOWEL HOLDER  
ART. ACB400.390  
ORO SCURO



DISPENSER / SOAP DISPENSER  
ART. ACB210.390  
ORO SCURO

ELIO  
SLIM

MET.



LAVABO / BASIN MIXER  
ART. EP830101.390  
ORO SCURO

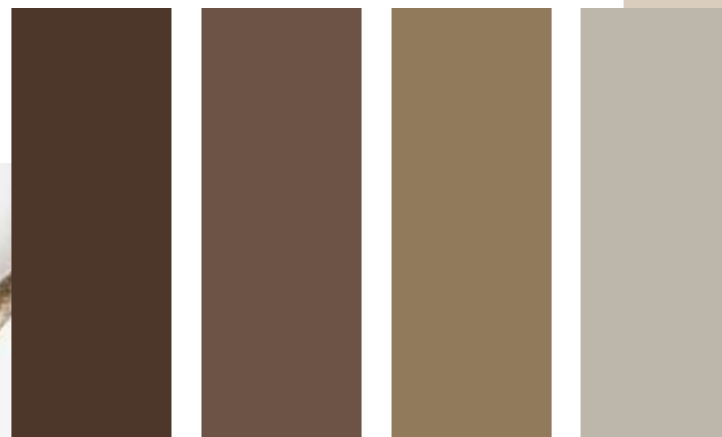

*Oro scuro*



# blu notte



ELIO SLIM



MATT.

KIT DOCCETTA / SHOWER KIT  
ART. AC0982.260

BRACCIO DOCCIA CON SOFFIONE /  
SHOWER ARM WITH SHOWER HEAD  
ART. AC0398.260



## EP830101

 Kg 1,3  
Box pcs 5



Miscelatore lavabo, scarico click-clack spessore regolabile, flex antitorsione cm 50 3/8" F.

One hole basin mixer, click-clack waste, antitorsion flex cm 50 3/8" F.

Mitigeur lavabo, vidage click-clack, flexibles antitorsion cm 50 3/8" F.

Einhebelmischer Waschtischbatterie mit up & down Ablaufgarnitur, mit flex. Anschlussschläuchen cm 50 3/8" F.

Monomando para lavabo con valvula click-clack, tubo flexible inoxidable de 50 cm, empalme 3/8" F.

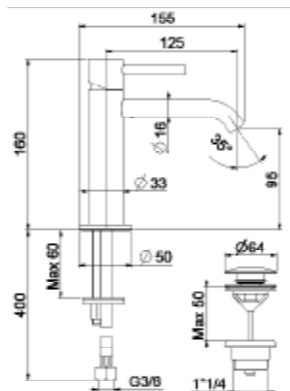

.015 Cromo / Chrome / Chromée / Verchromt / Cromo € 198,00

.560 Nero opaco / Matt black / Noir mat / Matt schwarz / Negro mate € 238,00

Collezione Primavera € 298,00

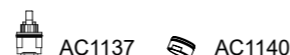

 EP830102

## EP833101

 Kg 1,5  
Box pcs 5



Miscelatore lavabo medio, scarico click-clack spessore regolabile, flex antitorsione cm 50 3/8" F.

One hole medium basin mixer, click-clack waste, antitorsion flex cm 50 3/8" F.

Mitigeur lavabo, vidage click-clack, flexibles antitorsion cm 50 3/8" F.

Einhebelmischer Waschtischbatterie mit up & down Ablaufgarnitur, mit flex. Anschlussschläuchen cm 50 3/8" F.

Monomando para lavabo con valvula click-clack, tubo flexible inoxidable de 50 cm, empalme 3/8" F.

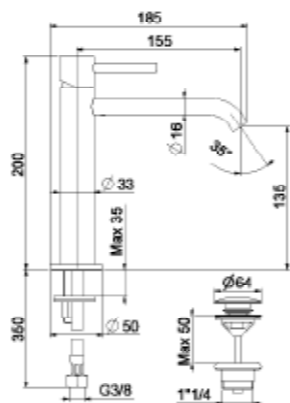

.015 Cromo / Chrome / Chromée / Verchromt / Cromo € 213,00

.560 Nero opaco / Matt black / Noir mat / Matt schwarz / Negro mate € 256,00

Collezione Primavera € 319,00

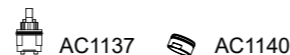

 EP833102

## EP830401

 Kg 2  
Box pcs 5



Miscelatore lavabo alto, scarico click-clack spessore regolabile, flex antitorsione cm 70 3/8" F.

One hole high basin mixer, click-clack waste, antitorsion flex cm 70 3/8" F.

Mitigeur lavabo haut, vidage click-clack, flexibles antitorsion cm 70 3/8" F.

Einhebelmischer Waschtischbatterie, mit hoher Ausführung, mit up & down Ablaufgarnitur, mit Flex. Anschlussschläuchen cm 70 3/8" F.

Monomando para lavabo alto con valvula click-clack, tubo flexible inoxidable de 70 cm, empalme 3/8" F.

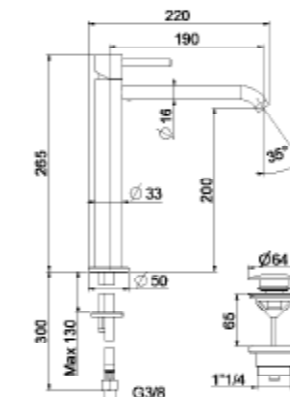

.015 Cromo / Chrome / Chromée / Verchromt / Cromo € 222,00

.560 Nero opaco / Matt black / Noir mat / Matt schwarz / Negro mate € 266,00

Collezione Primavera € 333,00

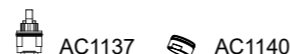

 EP830402

## EP840101

 Kg 1,3  
Box pcs 5



Miscelatore bidet, scarico click-clack spessore regolabile, flex antitorsione cm 50 3/8" F.

One hole bidet mixer, click-clack waste, antitorsion flex cm 50 3/8" F.

Mitigeur bidet, vidage click-clack, flexibles antitorsion cm 50 3/8" F.

Einhebelmischer Bidetbatterie mit up & down Ablaufgarnitur 1" 1/4, mit flex. Anschlussschläuchen cm 50 3/8" F.

Monomando para bidet con desagüe up & down, tubo flexible inoxidable de 50 cm, empalme 3/8" F.

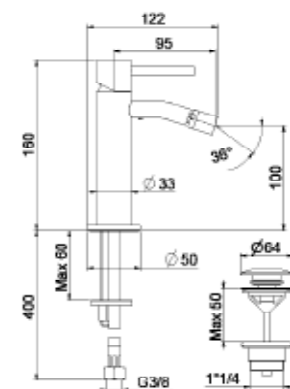

.015 Cromo / Chrome / Chromée / Verchromt / Cromo € 198,00

.560 Nero opaco / Matt black / Noir mat / Matt schwarz / Negro mate € 238,00

Collezione Primavera € 298,00

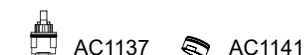

 EP840102

## EL830606

 Kg 2,1  
Box pcs 12



Miscelatore monocomando per lavabo incasso muro, con piastra orizzontale, senza scarico e flessibili.

Concealed single lever washbasin mixer, horizontal cover plate, without pop-up waste and flex hoses.

Mitigeur de lavabo à encastrer, rosace horizontale, sans vidage et flexibles.

Einhebelmischer Unterputz-Waschtischbatterie waagerechte Rosette, ohne Ablaufgarnitur und flex. Anschlussschläuchen.

Monomando empotrable para lavabo, de pared, con placa horizontal, sin desagüe ni tubos flexibles.

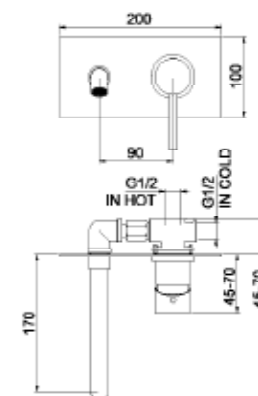

PER FINITURE CONSULTARE SEZIONE EASY BATHROOM A PAG. 260

FOR ALL AVAILABLE FINISHINGS PLEASE GO TO EASY BATHROOM P. 260

.015 Cromo / Chrome / Chromée / Verchromt / Cromo € 207,00



## EL830609

 Kg 2,1  
Box pcs 12



Miscelatore monocomando per lavabo incasso muro, con piastre separate, senza scarico e flessibili.

Concealed single lever washbasin mixer, with 2 cover plates, without pop-up waste and flex hoses.

Mitigeur de lavabo à encastrer, avec 2 rosaces, sans vidage et flexibles.

Einhebelmischer Unterputz-Waschtischbatterie, mit getrennten Platten, ohne Ablaufgarnitur und flex Anschlussschläuchen.

Monomando empotrable para lavabo de pared, con 2 placas, sin desagüe ni tubos flexibles.

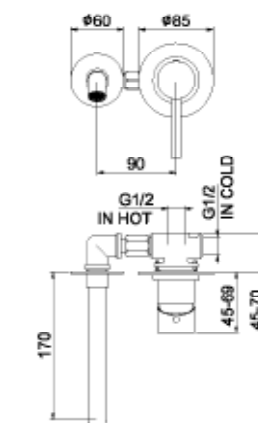

PER FINITURE CONSULTARE SEZIONE EASY BATHROOM A PAG. 260

FOR ALL AVAILABLE FINISHINGS PLEASE GO TO EASY BATHROOM P. 260

.015 Cromo / Chrome / Chromée / Verchromt / Cromado € 207,00



## EL850101

Kg 2,9  
Box pcs 6



Miscelatore monocomando per vasca esterno completo con flessibile in ottone da 150 cm doccetta multifunzione anticalcare e supporto.

Single lever bath mixer with shower set complete of brass hose 150 cm, multifunction handshower and holder.

Mitigeur bain-douche complet de flexible 150 cm, douchette multijet et support mural.

Einhebelmischer Badebatterie mit Brausegarnitur bestehend aus Metall-Brauseschlauch 150 cm, Massagehandbrause und Wandhalterung.

Monomando esterno para bañera completo, con tubo flexible de latón de 150 cm, ducha masaje antical y soporte.

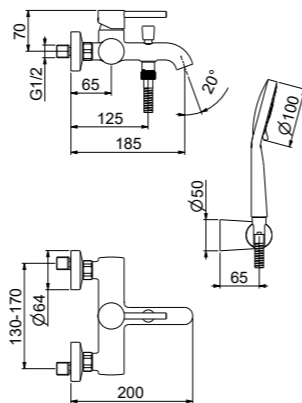

.015	Cromo / Chrome / Chromée / Verchromt / Cromo	€ 363,00
.560	Nero opaco / Matt black / Noir mat / Matt schwarz / Negro mate	€ 508,00
	Collezione Primavera	€ 580,00

Ø 35 mm  
AC0338000

153 + € 15,00

## EL850701

Kg 4,5  
Box pcs 6



Gruppo per bordo vasca 4 fori completo con flessibile in ottone da 150 cm e doccetta.

4-holes deck mounted bath mixer complete of brass hose 150 cm and handshower.

Mélangeur bain-douche 4-trous, flexible 150 cm et douchette.

4-Loch-Wannenrandarmatur mit Metallbrauseschlauch 150 cm und Handbrause.

Grupo para borde de bañera, 4 agujeros, con tubo flexible de latón, flexibles 150 cm y ducha.

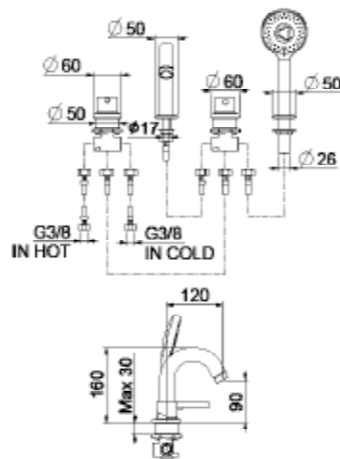

.015	Cromo / Chrome / Chromée / Verchromt / Cromo	€ 403,00
.560	Nero opaco / Matt black / Noir mat / Matt schwarz / Negro mate	€ 564,00
	Collezione Primavera	€ 644,00

Ø 35 mm  
AC0329000

AC0463015

Ø 35 mm  
AC0338000

Diametro foratura pannello vasca A-B-C-D = 28 mm  
Massimo spessore pannello vasca 40 mm / Diameter of the bath deck drilling A-B-C-D = 28 mm. Largest thickness of the bath deck 40 mm / Diamètre perçage du bord de la baignoire A-B-C-D=28 mm. Maximum épaisseur du bord de la baignoire 40 mm / Bohrungsdurchmesser der Wannenrandarmatur A-B-C-D=28 mm. Grösste Dicke der Wannenrandarmatur 40 mm / Diámetro agujero borde de bañera A-B-C-D = 28 mm. Máximo espesor borde de bañera 40 mm

## EL870102

Kg 2,2  
Box pcs 12



Miscelatore monocomando per doccia esterno; senza flessibile, doccetta e gancio di supporto.

Single lever shower mixer without shower set.

Mitigeur de douche sans garniture de douche.

Einhebelmischer Brausebatterie ohne Brausegarnitur.

Monomando esterno para ducha, sin tubo flexible, ducha ni gancho de soporte.

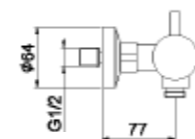
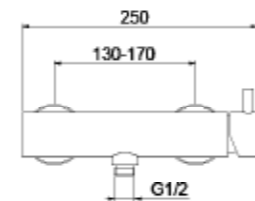

.015	Cromo / Chrome / Chromée / Verchromt / Cromo	€ 214,00
.560	Nero opaco / Matt black / Noir mat / Matt schwarz / Negro mate	€ 300,00
	Collezione Primavera	€ 312,00

Ø 35 mm  
AC0338000

153 + € 15,00

## EL851101

Kg 13  
Box pcs 1



Miscelatore monocomando per vasca a pavimento con flessibile, doccetta.

Single lever floor bath mixer with flexible hose, handshower.

Mitigeur baignoire au sol avec flexible, douchette.

Einhebelmischer Stand-Badebatterie mit Brauseschlauch, Handbrause.

Monomando para bañera de suelo, con flexible y ducha de mano.

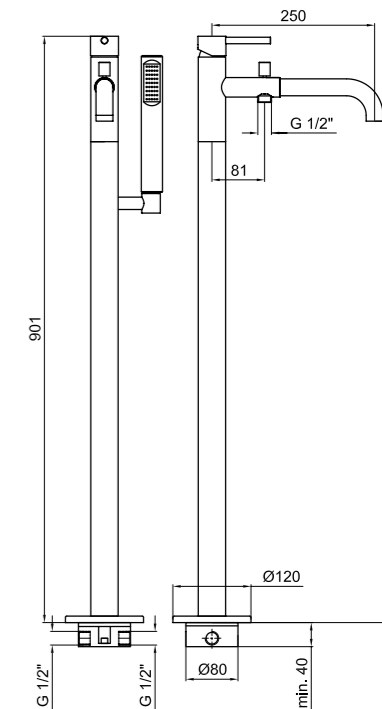

.015	Cromo / Chrome / Chromée / Verchromt / Cromo	€ 973,00
.560	Nero opaco / Matt black / Noir mat / Matt schwarz / Negro mate	€ 1.362,00
	Collezione Primavera	€ 1.557,00

AC0823015

AC0471000

Ø 35 mm  
AC0361

## EL880101

Kg 1,1  
Box pcs 12



Miscelatore monocomando per doccia incasso, con piastra, senza flessibile, doccetta e gancio.

Concealed single lever shower mixer with cover plate, without shower set.

Mitigeur de douche à encastrer avec rosace, sans garniture de douche.

Einhebelmischer Unterputz-Brausebatterie, mit Rosette, ohne Brausegarnitur.

Monomando empotrable para ducha, con placa, sin tubo flexible, ducha ni gancho.

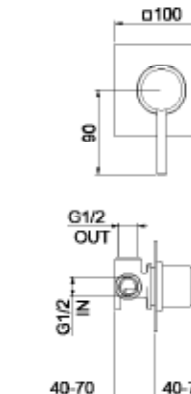

PER FINITURE CONSULTARE  
SEZIONE EASY BATHROOM A PAG. 260

FOR ALL AVAILABLE FINISHINGS  
PLEASE GO TO EASY BATHROOM P. 260

.015	Cromo / Chrome / Chromée / Verchromt / Cromo	€ 122,00
------	--	----------

AC0359015

Ø 35 mm  
AC0338000

# EL860101

Kg 3,2  
Box pcs 6



Miscelatore monocomando per vasca incasso, con deviatore, piastra orizzontale, senza flessibile doccia e gancio di supporto.

Concealed single lever bath mixer with diverter, horizontal cover plate, without shower set.

Mitigeur bain-douche à encastrer avec inverseur, rosace horizontale, sans garniture de douche.

Einhebelmischer Unterputz-Badebatterie mit Umstellung, waagerechte Rosette, ohne Brausegarnitur.

Monomando empotrable para bañera, con desviador, placa horizontal, sin tubo flexible, ducha ni gancho de soporte.

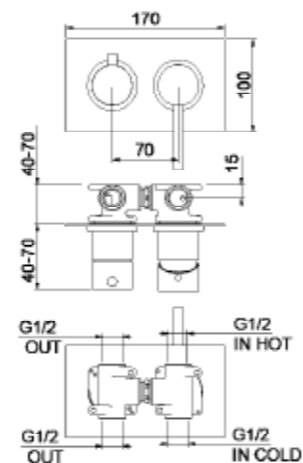

PER FINITURE CONSULTARE  
SEZIONE EASY BATHROOM A PAG. 260

FOR ALL AVAILABLE FINISHINGS  
PLEASE GO TO EASY BATHROOM P. 260

.015 Cromo / Chrome / Chromée / Verchromt / Cromo

€ 224,00

Ø 35 mm  
AC0329000

Ø 35 mm  
AC0338000

AC0357015





LAVABO / BASIN MIXER  
ART. EA830101.440

LAVABO ALTO / HIGH BASIN MIXER  
ART. EA830401.440

# ELIO STEEL

100 %  
STAINLESS  
STEEL 316L



Elio Steel permette, con la sua gamma completa in acciaio inox 316L, di realizzare il proprio bagno utilizzando solo articoli prodotti con questo materiale: dai lavabi con il rispettivo scarico, ai miscelatori esterni, ai doccia con tutti i relativi accessori.

With its full range in 316L stainless steel, Elio Steel allows you to create your own bathroom by exclusively using items made of this material: from washbasin mixers with their wastes, to external mixers, to shower mixers with all their accessories.

## EA830101

1,9 kg



Miscelatore lavabo, testa cieca, flex antitorsione cm 50 3/8"F.

One hole basin mixer, without waste, antitorsion flex cm 50 3/8"F.

Mitigeur lavabo, sans vidage, flexibles antitorsion cm 50 3/8"F.

Waschtischmischer ohne Ablaufgarnitur, Anti-Torsion Schläuche 50 cm 3/8"F.

Mezclador lavabo sin desagüe, flexibles antitorsión cm 50 3/8"F.

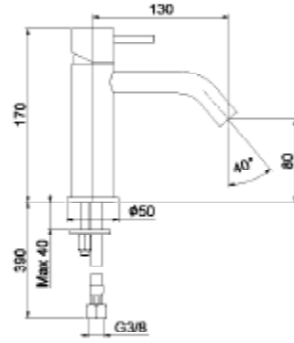

EA830102

.440 Acciaio inox 316L  
Stainless steel 316L

€ 339,00

AC1144

## EA830401

2,8 kg



Miscelatore lavabo alto, testa cieca, flex antitorsione cm 70 3/8"F.

One hole high basin mixer, without waste, antitorsion flex cm 70 3/8"F.

Mitigeur lavabo haut, sans vidage, flexibles antitorsion cm 70 3/8"F.

Höher Waschtischmischer ohne Ablaufgarnitur, Anti-Torsion Schläuche 70 cm 3/8"F.

Mezclador lavabo sin desagüe, flexibles antitorsión cm 70 3/8"F.

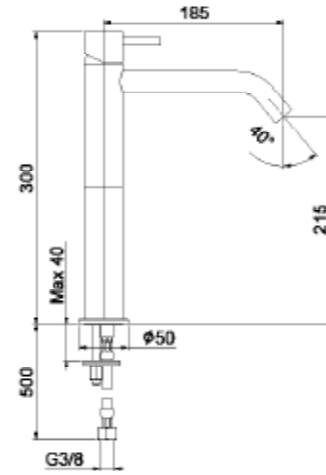

EA830402

.440 Acciaio inox 316L  
Stainless steel 316L

€ 509,00

AC1144

## EA840101

1,9 kg



Miscelatore bidet, testa cieca, flex antitorsione cm 50 3/8"F.

One hole bidet mixer, without waste, antitorsion flex cm 50 3/8"F.

Mitigeur bidet, sans vidage, flexibles antitorsion cm 50 3/8"F.

Bidetmischer ohne Ablaufgarnitur, Anti-Torsion Schläuche 50 cm 3/8"F.

Mezclador de bidé sin desagüe, flexibles antitorsión cm 50 3/8"F.

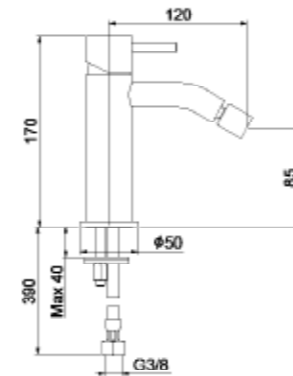

EA840102

.440 Acciaio inox 316L  
Stainless steel 316L

€ 408,00

AC1144

## EA830616

2 kg



Miscelatore monocomando per lavabo a muro.

Concealed single lever washbasin mixer, with cover plates.

Mitigeur de lavabo à encastrer, avec 2 rosaces.

Einhebelmischer Unterputz-Waschtischbatterie, mit getrennten Platten.

Monomando empotrable para lavabo de pared, con 2 placas.

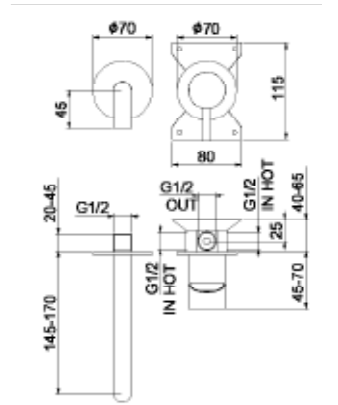

.440 Acciaio inox 316L  
Stainless steel 316L

€ 598,00

AC0338

## EA832101

9 kg



Miscelatore lavabo a pavimento.

Floor-mounted wash basin mixer.

Mitigeur lavabo pour montage en îlot.

Einhebelmischer Stand-Waschtischbatterie.

Monomando de pie para lavabo.

## AC1100



Corpo incasso.

Built-in body.

Corps intégré.

Einbaukörper.

Cuerpo empotrado.

€ 234,00

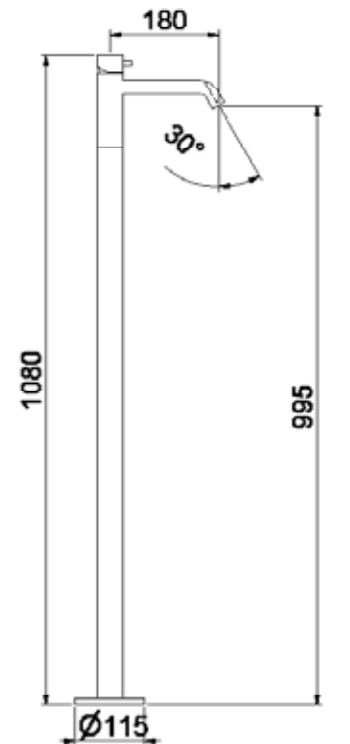

.440 Acciaio inox 316L  
Stainless steel 316L

€ 1.550,00

AC1144

## EA851101

10 kg



Miscelatore vasca a pavimento con duplex.  
Floor-mounted bath mixer with shower set.  
Mitigeur bain douche pour montage en flot.

Einhebelmischer Stand-Badebatterie mit Brauseschlauch, Handbrause.

Monomando para bañera de pie, con flexible y ducha.

### AC1100



Corpo incasso.  
Built-in body.  
Corps intergré.  
Einbaukörper.  
Cuerpo empotrado.

€ 234,00

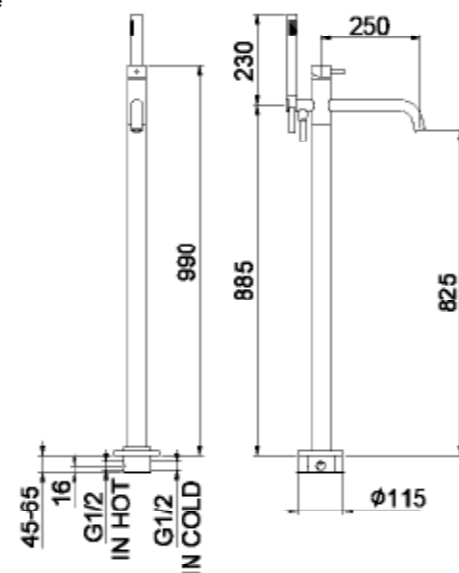

.440 Acciaio inox 316L  
Stainless steel 316L

€ 1.958,00



AC1165

## EA850102

3 kg



Miscelatore vasca senza duplex.  
Bath mixer without shower set.  
Mitigeur bain douche sans garniture.

Einhebelmischer Badebatterie ohne Brausegarnitur.

Monomando esterno para bañera, sin tubo flexible, ducha ni gancho de soporte.

N.B  
Corpo esterno in acciaio inossidabile 316L, anima interna in ottone  
316L stainless steel outer body, internal core in brass

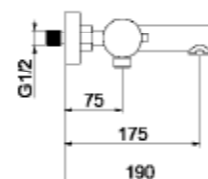
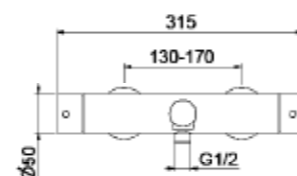

.440 Acciaio inox 316L  
Stainless steel 316L

€ 1.040,00



AC0338

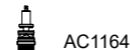

AC1164

## EA980201

3 kg



Miscelatore termostatico vasca esterno senza duplex.  
Thermostatic bath mixer without shower set.  
Mitigeur thermostatique bain douche sans garniture.  
Thermostat Wannenmischer ohne Brausegarnitur.  
Mezclador termostático para bañera exterior sin kit de ducha.

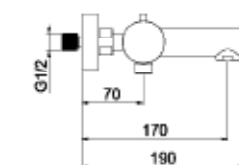
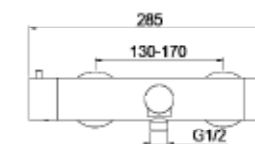

.440 Acciaio inox 316L  
Stainless steel 316L

€ 1.076,00



AC1167



AC1166

## EA850701

4 kg



Miscelatore bordo vasca 4 fori con doccia.  
4-hole bath mixer with shower.  
Mitigeur bain douche à 4 trous avec douche.

4-Loch Wannenmischer mit Handbrause.

Mezclador para borde de bañera, 4 agujeros, con ducha.

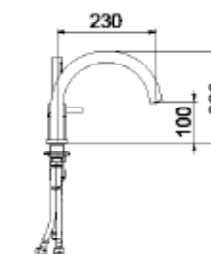
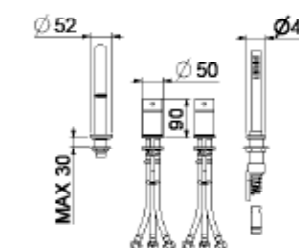

.440 Acciaio inox 316L  
Stainless steel 316L

€ 1.208,00

## EA870102

2,7 kg



Miscelatore doccia esterno senza duplex.  
External shower mixer without shower set.  
Mitigeur douche extérieur sans garniture.

Einhebelmischer Brausebatterie ohne Brausegarnitur.

Monomando esterno para ducha, sin tubo flexible, ducha ni gancho de soporte.

N.B  
Corpo esterno in acciaio inossidabile 316L, anima interna in ottone  
316L stainless steel outer body, internal core in brass

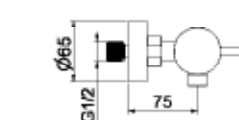
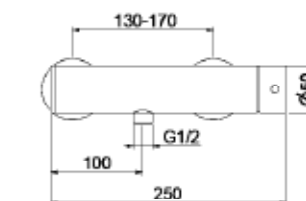

.440 Acciaio inox 316L  
Stainless steel 316L

€ 836,00



AC0338

## EA980102

2,7 kg



Miscelatore termostatico doccia esterno senza duplex.  
 Thermostatic external mixer without shower set.  
 Mitigeur thermostatique douche sans garniture.  
 Thermostat Brausebatterie ohne Brausegarnitur.  
 Mezclador termostatico externo para ducha, sin tubo flexible.

N.B  
 Corpo esterno in acciaio inossidabile 316L, anima interna in ottone  
 316L stainless steel outer body, internal core in brass

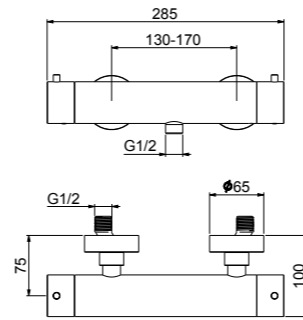

.440 Acciaio inox 316L  
 Stainless steel 316L

€ 876,00

AC1167

AC1166

## AC1097

0,6 kg



Supporto, doccetta monogetto e flessibile satilux.  
 Shower set composed of holder, monospray handshower and satilux flex hose.  
 Garniture de douche composée de support mural, douchette mono-jet et flexible satilux.  
 Brausehalter, Einstrahl-Handbrause und Satilux-Schlauch.  
 Soporte, ducha un chorro y flexible Satilux.



.440 Acciaio inox 316L  
 Stainless steel 316L

€ 143,00

## EA880101

1,5 kg



Miscelatore doccia incasso con corpo in acciaio inox.  
 Built-in shower mixer with stainless steel with built-in body.  
 Mitigeur douche à encastrer avec corps à encastrer en inox..  
 Einhebelmischer Unterputz-Brausebatterie, mit Rosette ohne Brausegarnitur mit Edelstahl Körper.  
 Monomando empotrable para ducha, con cuerpo empotrado en acer.

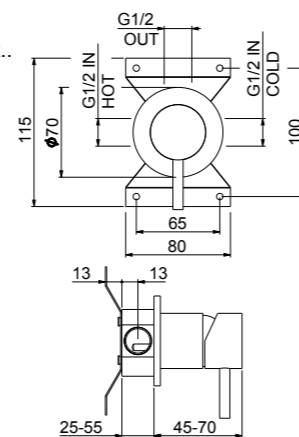

.440 Acciaio inox 316L  
 Stainless steel 316L

€ 433,00

AC0338

## EA881301

1,5 kg



Miscelatore doccia incasso con corpo in ottone.  
 Built-in shower mixer with brass built-in body.  
 Mitigeur douche à encastrer avec corps en laiton.  
 Unterputz Duschenmischer mit Messingkörper.  
 Mezclador ducha empotrable con cuerpo empotrado en latón.

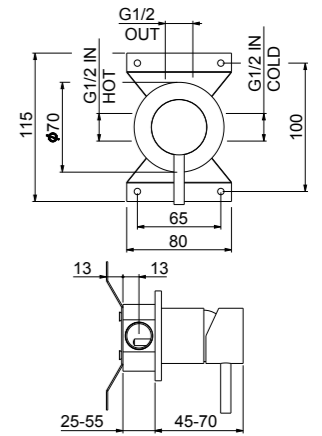

.440 Acciaio inox 316L  
 Stainless steel 316L

€ 340,00

AC0338

## EA860122

2,5 kg



Miscelatore doccia incasso con deviatore, due uscite, con corpo in acciaio inox  
 2-way built-in shower mixer with diverter, with stainless steel built-in body.  
 Mitigeur douche à encastrer avec inverseur, deux sorties, avec corps à encastrer en inox.  
 Einhebelmischer Unterputz-Badebatterie mit 2 Weg Umstellung, ohne Brausegarnitur mit Edelstahl Körper.  
 Monomando empotrable para baño-ducha, con desviador 2 vías, con cuerpo empotrado en acero.

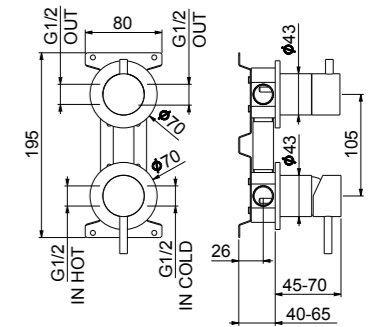

.440 Acciaio inox 316L  
 Stainless steel 316L

€ 881,00

AC0338

## EA861301

2,5 kg



Miscelatore doccia incasso con deviatore, due uscite con corpo in ottone.  
 2-way built-in shower mixer with diverter, brass built-in body.  
 Mitigeur douche à encastrer avec inverseur, deux sorties, corps en laiton.  
 2-Weg Unterputz Duschenmischer mit Umsteller und Messingkörper.  
 Mezclador ducha empotrable con desviador, dos vías, con cuerpo empotrado en latón.

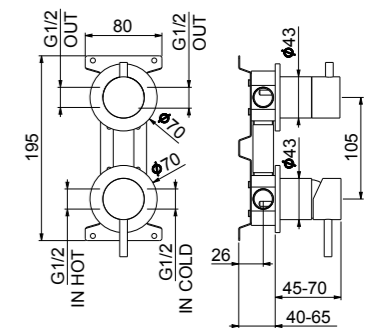

.440 Acciaio inox 316L  
 Stainless steel 316L

€ 664,00

AC0338

## AC1092

0,8 kg



Kit supporto doccetta e flessibile satilux con presa acqua.

Shower set composed of holder, hand shower, satilux flex and intake of water.

Garniture de douche composée de support mural, douchette, flexible satilux et prise d'eau.

Brausegarnitur bestehend aus Wandhalterung, 1 Funktion Handbrause, Schlauch und Anschlusswinkel.

Kit de ducha con soporte, ducha, tubo flexible y toma de agua.

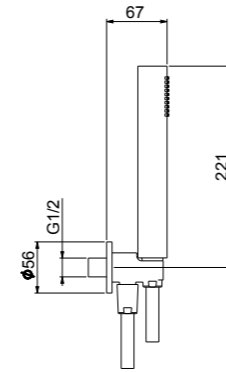

.440 Acciaio inox 316L  
Stainless steel 316L

€ 328,00

## AC1094

1,8 kg



Soffione tondo Ø 200 mm ultra sottile con braccio alimentazione laterale 350 mm.

Ultra-thin round shower head Ø 200 mm in with horizontal inlet arm 350 mm.

Pomme de douche ronde Ø 200 mm ultrafine avec bras mural 350 mm.

Runder ultradünner Duschkopf Ø200 mm mit Seitenarm 350 mm.

Rociador redondo Ø 200 mm ultra fino con brazo de alimentación lateral de 350 mm.

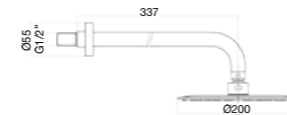

.440 Acciaio inox 316L  
Stainless steel 316L

€ 315,00

## AC1095

1,8 kg



Soffione tondo Ø 200 mm ultra sottile con braccio alimentazione verticale 300 mm.

Ultra-thin round shower head Ø 200 mm with ceiling inlet arm 300 mm.

Pomme de douche ronde Ø 200 mm ultrafine avec bras d'alimentation vertical 300 mm.

Runder ultradünner Duschkopf Ø200 mm mit Deckenarm 300 mm.

Rociador redondo Ø 200 mm ultra fino con brazo de alimentación vertical de 300 mm.

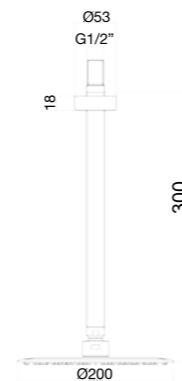

.440 Acciaio inox 316L  
Stainless steel 316L

€ 269,00

## AC1093

2 kg



Set saliscendi con doccia Minimal 1g. flex satilux.

Sliding rail set with single jet minimal shower, satilux flexible.

Kit barre de douche avec douchette minimale 1 jet, flexible satilux.

Gleitstange mit minimaler Einstrahl-Handbrause, Satilux-Schlauch.

Conjunto de barra de ducha con ducha Minimal un chorro y flexible Satilux..

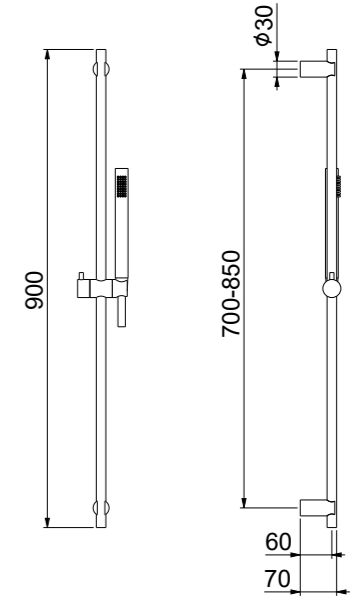

.440 Acciaio inox 316L  
Stainless steel 316L

€ 682,00

## EA980507

12 kg



Miscelatore termostatico per doccia esterno, versione completa di colonna telescopica, soffione e doccetta monogetto.

Thermostatic shower mixer with telescopic column, shower head and monospray handshower.

Colonne de douche télescopique thermostatique avec pomme de douche et douchette monojet.

Thermostat-Duschenmischer mit teleskopischer Duschsäule, Duschkopf und Einstrahl-Handbrause.

Mezclador termostático para ducha exterior, versión completa de columna telescópica, rociador y ducha un chorro.

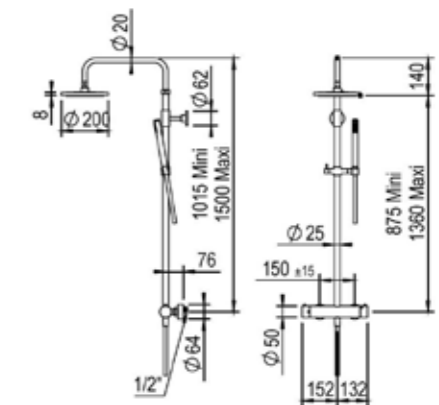

.440 Acciaio inox 316L  
Stainless steel 316L

€ 2.250,00

## AC1096

0,8 kg



Sifone minimal tondo.  
Round minimal siphon.  
Siphon en laiton minimal rond.  
Flaschensifon 1"1/4.  
Sifón de 1"1/4.

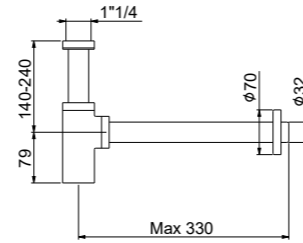

.440 Acciaio inox 316L  
Stainless steel 316L € 226,00

## AC1098

0,3 kg



Scarico "click-clack" spessore regolabile.  
"Click-clack" pop up waste.  
Vidage "click-clack".  
Ablaufventil "Up & Down" 1"1/4 mit Ueberlauf.  
Válvula click-clack con rebosadero de 1"1/4.

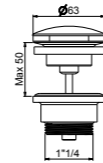

.440 Acciaio inox 316L  
Stainless steel 316L € 48,00



NON -  
TOXIC



L'acciaio inox è un materiale **sano, duraturo, atossico**.

Non contiene tracce di piombo e non rilascia nichel.  
A livello produttivo viene trattato solo meccanicamente, non subisce alcun processo chimico che può essere causa di inquinamento. Garantisce una durata eccezionale, data la sua solidità, ed è uno dei materiali migliori per il contatto con l'acqua potabile.

Stainless steel is a **healthy, durable, non-toxic material**.

It contains no traces of lead and it does not release nickel.  
At the production level it is treated only mechanically; it does not undergo any chemical processes that can cause pollution. It provides exceptional durability, given its strength, and it is one of the best materials for contact with drinking water.

**ACC400.220**  
Porta salviette.  
Towel holder.

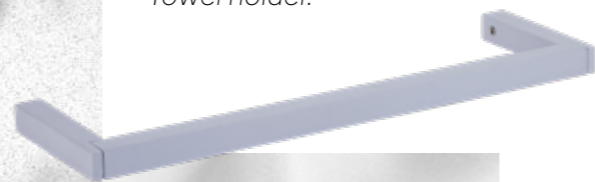

**OR880601.220**

Doccia incasso con deviatore 3 vie.  
3-way built-in shower mixer.



**AC1126.220**

Soffioncino body spray.  
Body jet spray shower.



**AC1045.220**

Kit doccia.  
Shower kit.

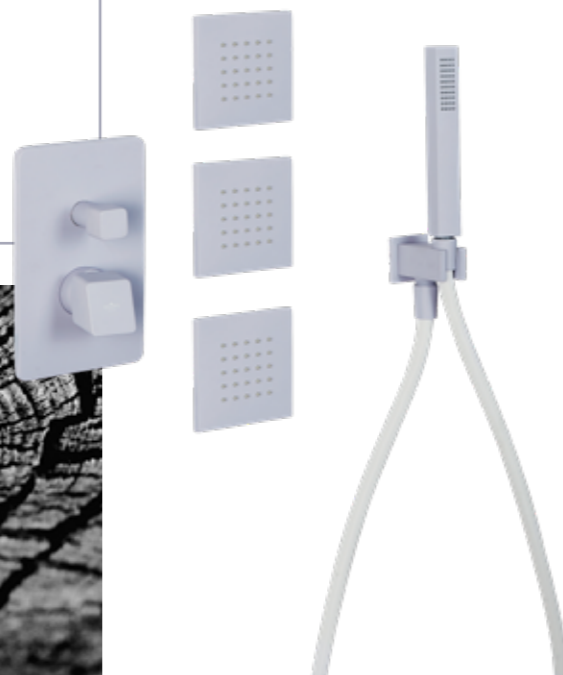

**AC1113.220**

Soffione 300x300 mm.  
Shower head 300x300 mm.

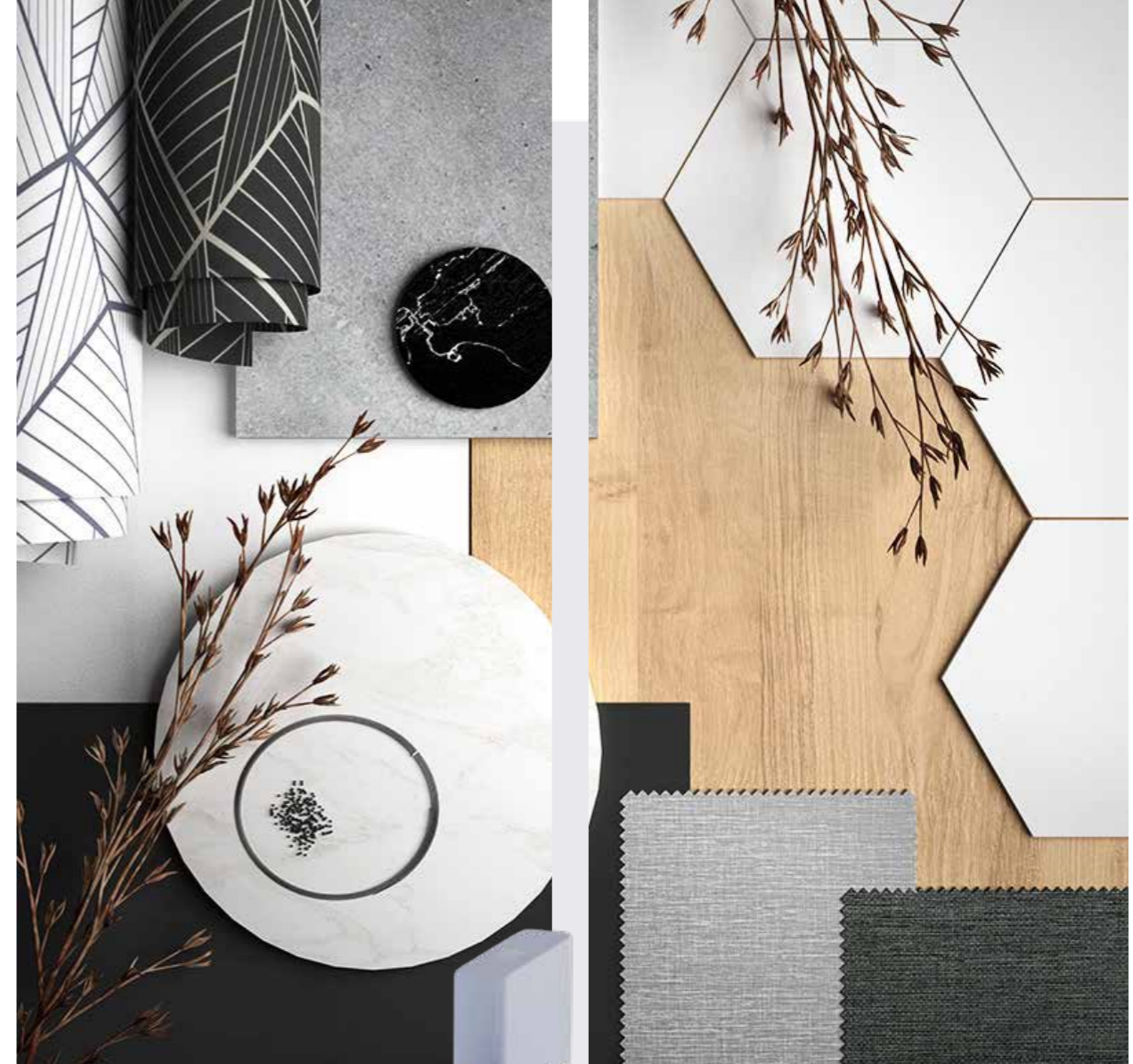

**OR830401.220**  
Miscelatore lavabo alto  
One hole basin mixer, high body.

**OMBRA**

# OMBRA



OR830609.015  
Miscelatore lavabo a muro.  
Wall basin mixer.

Finiture / finishes / finitions / ausföhrungen / acabados

.015	.560	Collezione
Cromo	Nero opaco	Primavera
Chrome	Matt black	
Chromée	Noir mat	
Verchromt	Matt schwarz	
Cromo	Negro mate	

Dall'incontro tra design moderno, passione e una sempre più fondamentale ricerca di essenzialità e bisogno di praticità, nasce Ombra. Dinamismo, sobrietà ed eleganza sono le caratteristiche che più contraddistinguono la nuova serie di Webert. Il design fiero è ideato per garantire la praticità di utilizzo e al contempo appagare i gusti estetici più ricercati, creando ispirazione all'interno dell'ambiente bagno e conferendogli un carattere innato e anticonformista.

Modern design, passion, an increasingly fundamental search for essentiality and the need of practicality meet giving birth to Ombra. Dynamism, sobriety and elegance are the main features of the new series by Webert. Conceived both to guarantee serviceability and to satisfy most refined aesthetic tastes, its proud design creates inspiration in the bathroom environment by endowing it with a natural and unconventional character.



OR880601.015  
Miscelatore doccia incasso con  
deviatore ceramico 3 vie.  
3-way built-in shower mixer with  
ceramic diverter.





## OR830101

1,8 kg



Miscelatore lavabo, scarico click-clack spessore regolabile, flex antitorsione cm 50 3/8" F.

One hole basin mixer, click-clack waste, antitorsion flex cm 50 3/8" F.

Mitigeur lavabo, vidage click-clack, flexibles antitorsion cm 50 3/8" F.

Einhebelmischer Waschtischbatterie mit up & down Ablaufgarnitur, mit flex. Anschlussschläuchen cm 50 3/8" F.

Monomando para lavabo con valvula click-clack, tubo flexible inoxidable de 50 cm, empalme 3/8" F.

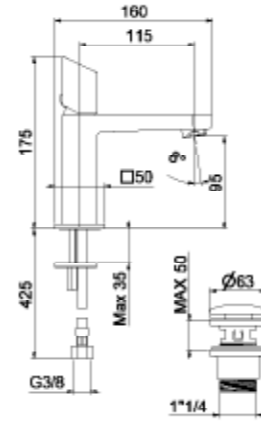

.015	Cromo / Chrome / Chromée / Verchromt / Cromo	€ 102,00
.560	Nero opaco / Matt black / Noir mat / Matt schwarz / Negro mate	€ 142,00
	Collezione Primavera	€ 186,00

OR830102

AC1132 AC0462

## OR830201

1,6 kg



Miscelatore lavabo, testa cieca, flex antitorsione cm 50 3/8" F.

One hole basin mixer, without pop up waste, antitorsion flex cm 50 3/8" F.

Mitigeur lavabo, sans vidage, flexibles antitorsion cm 50 3/8" F.

Einhebelmischer Waschtischbatterie ohne up & down Ablaufgarnitur, mit flex. Anschlussschläuchen cm 50 3/8" F.

Monomando para lavabo sin valvula click-clack, tubo flexible inoxidable de 50 cm, empalme 3/8" F.

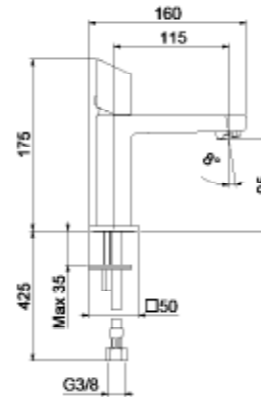

.015	Cromo / Chrome / Chromée / Verchromt / Cromo	€ 90,00
.560	Nero opaco / Matt black / Noir mat / Matt schwarz / Negro mate	€ 108,00
	Collezione Primavera	€ 145,00

OR830202

AC1132 AC0462

## OR833101

2 kg



Miscelatore lavabo medio, scarico click-clack spessore regolabile, flex antitorsione cm 50 3/8" F.

One hole medium basin mixer, click-clack waste, antitorsion flex cm 50 3/8" F.

Mitigeur lavabo, vidage click-clack, flexibles antitorsion cm 50 3/8" F.

Einhebelmischer Waschtischbatterie mit up & down Ablaufgarnitur, mit flex. Anschlussschläuchen cm 50 3/8" F.

Monomando para lavabo con valvula click-clack, tubo flexible inoxidable de 50 cm, empalme 3/8" F.

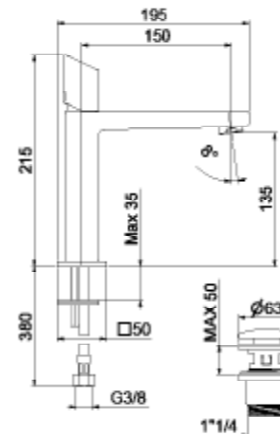

.015	Cromo / Chrome / Chromée / Verchromt / Cromo	€ 117,00
.560	Nero opaco / Matt black / Noir mat / Matt schwarz / Negro mate	€ 164,00
	Collezione Primavera	€ 211,00

OR833102

AC1132 AC0462

## OR833601

1,8 kg



Miscelatore lavabo medio, testa cieca, flex antitorsione cm 50 3/8" F.

One hole medium basin mixer, without pop up waste, antitorsion flex cm 50 3/8" F.

Mitigeur lavabo, sans vidage, flexibles antitorsion cm 50 3/8" F.

Einhebelmischer Waschtischbatterie ohne up & down Ablaufgarnitur, mit flex. Anschlussschläuchen cm 50 3/8" F.

Monomando para lavabo sin valvula click-clack, tubo flexible inoxidable de 50 cm, empalme 3/8" F.

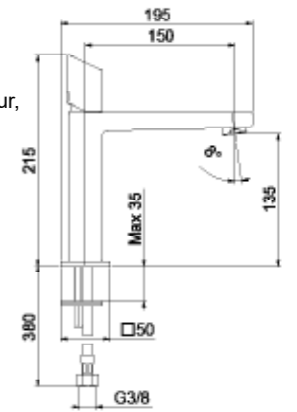

.015	Cromo / Chrome / Chromée / Verchromt / Cromo	€ 107,00
.560	Nero opaco / Matt black / Noir mat / Matt schwarz / Negro mate	€ 128,00
	Collezione Primavera	€ 169,00

OR833602

AC1132 AC0462

## OR830401

2,7 kg



Miscelatore lavabo alto, scarico click-clack spessore regolabile, flex antitorsione cm 70 3/8" F.

One hole high basin mixer, click-clack waste, antitorsion flex cm 70 3/8" F.

Mitigeur lavabo haut, vidage click-clack, flexibles antitorsion cm 70 3/8" F.

Einhebelmischer Waschtischbatterie, mit hoher Ausführung, mit up & down Ablaufgarnitur, mit Flex. Anschlussschläuchen cm 70 3/8" F.

Monomando para lavabo alto con valvula click-clack, tubo flexible inoxidable de 70 cm, empalme 3/8" F.

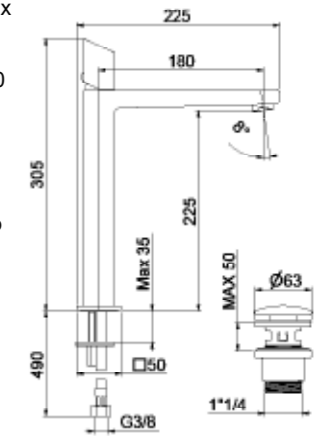

.015	Cromo / Chrome / Chromée / Verchromt / Cromo	€ 185,00
.560	Nero opaco / Matt black / Noir mat / Matt schwarz / Negro mate	€ 259,00
	Collezione Primavera	€ 323,00

OR830402

AC1132 AC0462

## OR833701

2,5 kg



Miscelatore lavabo alto, testa cieca, flex antitorsione cm 70 3/8" F.

One hole high basin mixer, without pop up waste, antitorsion flex cm 70 3/8" F.

Mitigeur lavabo haut, sans vidage, flexibles antitorsion cm 70 3/8" F.

Einhebelmischer Waschtischbatterie ohne up & down Ablaufgarnitur, mit flex. Anschlussschläuchen cm 70 3/8" F.

Monomando para lavabo sin valvula click-clack, tubo flexible inoxidable de 70 cm, empalme 3/8" F.

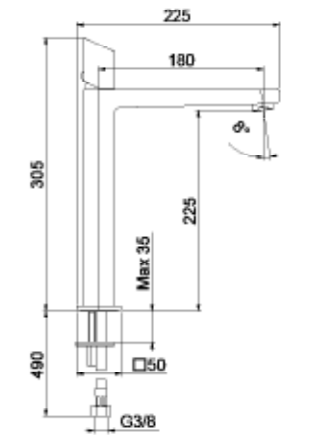

.015	Cromo / Chrome / Chromée / Verchromt / Cromo	€ 174,00
.560	Nero opaco / Matt black / Noir mat / Matt schwarz / Negro mate	€ 209,00
	Collezione Primavera	€ 264,00

OR833702

AC1132 AC0462

## OR840101

1,7 kg



Miscelatore bidet, scarico click-clack spessore regolabile, flex antitorsione cm 50 3/8" F.

One hole bidet mixer, click-clack waste, antitorsion flex cm 50 3/8" F.

Mitigeur bidet, vidage click-clack, flexibles antitorsion cm 50 3/8" F.

Einhebelmischer Bidetbatterie mit up & down Ablaufgarnitur 1" 1/4, mit flex. Anschlussschläuchen cm 50 3/8" F.

Monomando para bidé con desagüe up & down, tubo flexible inoxidable de 50 cm, empalme 3/8" F.

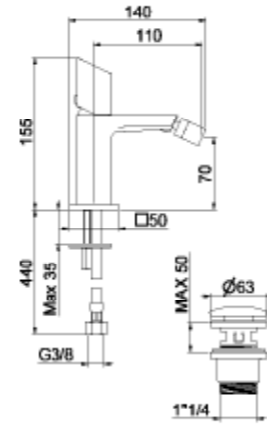

.015 Cromo / Chrome / Chromée / Verchromt / Cromo € 97,00

.560 Nero opaco / Matt black / Noir mat / Matt schwarz / Negro mate € 136,00

Collezione Primavera € 176,00

AC1132 AC0990

OR840102

## OR840201

1,5 kg



Miscelatore bidet, testa cieca, flex antitorsione cm 50 3/8" F.

One hole bidet mixer, without pop up waste, antitorsion flex cm 50 3/8" F.

Mitigeur bidet, sans vidage, flexibles antitorsion cm 50 3/8" F.

Einhebelmischer Bidetbatterie ohne up & down Ablaufgarnitur, mit flex. Anschlussschläuchen cm 50 3/8" F.

Monomando para bidet sin valvula click-clack, tubo flexible inoxidable de 50 cm, empalme 3/8" F.

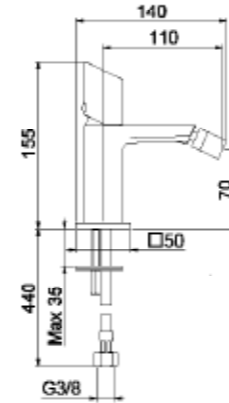

.015 Cromo / Chrome / Chromée / Verchromt / Cromo € 85,00

.560 Nero opaco / Matt black / Noir mat / Matt schwarz / Negro mate € 102,00

Collezione Primavera € 136,00

AC1132 AC0990

OR840202

## OR830701

2 kg



Miscelatore lavabo a due fori.

2-holes washbasin mixer.

Mitigeur de lavabo 2-trous

2-Loch-Einhebelmischer.

Grifo bimando para lavabo, 2 agujeros.

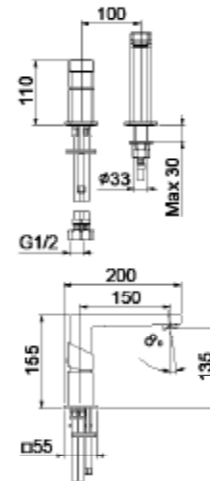

.015 Cromo / Chrome / Chromée / Verchromt / Cromo € 194,00

.560 Nero opaco / Matt black / Noir mat / Matt schwarz / Negro mate € 234,00

Collezione Primavera € 349,00

AC0338 AC0462

## OR750102

2,6 kg



Batteria per lavabo a tre fori completa con scarico up & down.

3-holes washbasin mixer with up & down pop-up waste.

Mélangeur de lavabo 3-trous bec fixe avec vidage up & down.

3-Loch-Waschtischbatterie mit up & down Ablaufgarnitur.

Grifo bimando para lavabo de repisa, 3 agujeros, desagüe up & down.

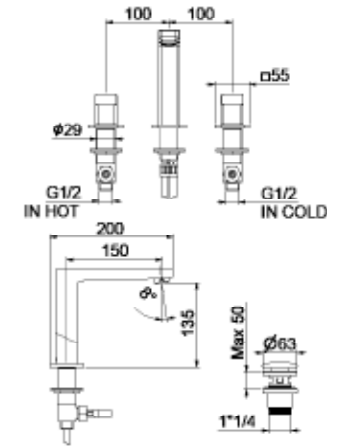

.015 Cromo / Chrome / Chromée / Verchromt / Cromo € 338,00

.560 Nero opaco / Matt black / Noir mat / Matt schwarz / Negro mate € 408,00

Collezione Primavera € 507,00

AC0331 AC0332 AC0462

## OR830606

2 kg



Miscelatore monocomando per lavabo incasso muro, con piastra orizzontale, senza scarico e flessibili.

Concealed single lever washbasin mixer, horizontal cover plate, without pop-up waste and flex hoses.

Mitigeur de lavabo à encastrer, rosace horizontale, sans vidage et flexibles.

Einhebelmischer Unterputz-Waschtischbatterie waagerechte Rosette, ohne Ablaufgarnitur und flex. Anschlussschläuchen.

Monomando empotrable para lavabo de pared, con placa horizontal, sin desagüe ni tubos flexibles.

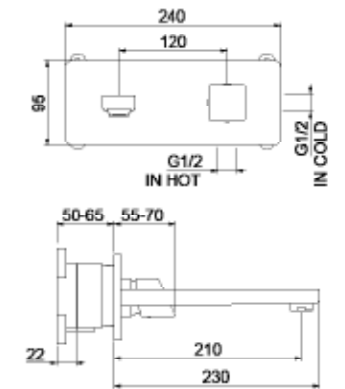

PER FINITURE CONSULTARE SEZIONE EASY BATHROOM A PAG. 260

FOR ALL AVAILABLE FINISHINGS PLEASE GO TO EASY BATHROOM P. 260

.015 Cromo / Chrome / Chromée / Verchromt / Cromo € 176,00

AC0338 AC0462

## OR830609

2 kg



Miscelatore monocomando per lavabo incasso muro, con piastre separate, senza scarico e flessibili.

Concealed single lever washbasin mixer, with cover plates, without pop-up waste and flex hoses.

Mitigeur de lavabo à encastrer, avec 2 rosaces, sans vidage et flexibles.

Einhebelmischer Unterputz-Waschtischbatterie, mit getrennten Platten, ohne Ablaufgarnitur und flex Anschlussschläuchen.

Monomando empotrable para lavabo de pared, con 2 placas, sin desagüe ni tubos flexibles.

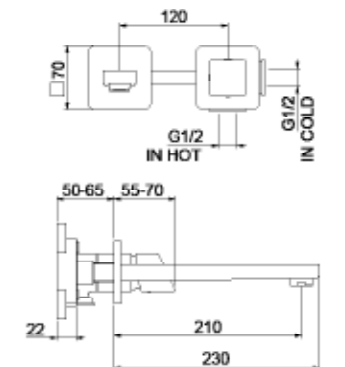

PER FINITURE CONSULTARE SEZIONE EASY BATHROOM A PAG. 260

FOR ALL AVAILABLE FINISHINGS PLEASE GO TO EASY BATHROOM P. 260

.015 Cromo / Chrome / Chromée / Verchromt / Cromo € 166,00

AC0338 AC0462

## OR851101

8,5 kg

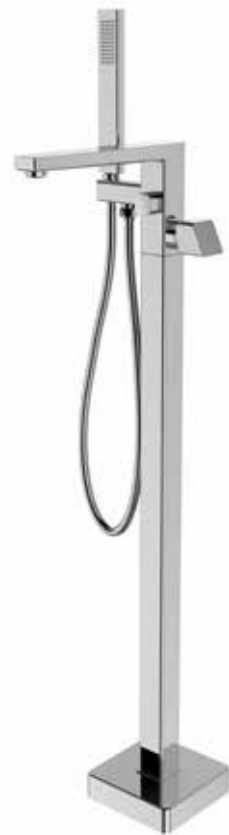

Miscelatore monocomando per vasca a pavimento con flessibile, doccetta.

Single lever floor bath mixer with flexible hose, handshower.

Mitigeur baignoire au sol avec flexible, douchette.

Einhebelmischer Stand-Badebatterie mit Brauseschlauch, Handbrause.

Monomando para bañera de pie, con flexible y ducha.

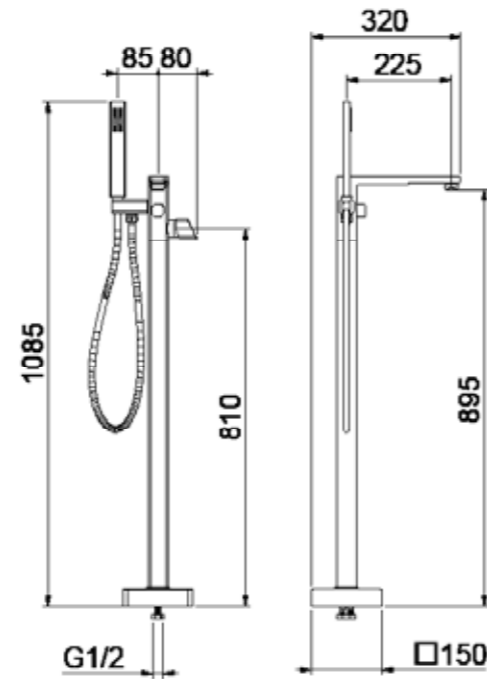

.015 Cromo / Chrome / Chromée / Verchromt / Cromo € 1.038,00

.560 Nero opaco / Matt black / Noir mat / Matt schwarz / Negro mate € 1.453,00

Collezione Primavera € 1.868,00

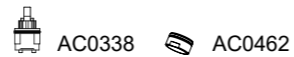

## OR730101

5 kg



Gruppo per bordo vasca 4 fori completo con flessibile da 150 cm e doccetta.

4-holes deck mounted bath mixer complete of hose 150 cm and handshower.

Mitigeur bain-douche 4-trous, flexible 150 cm et douchette.

4-Loch-Wannenrandarmatur mit Metallbrauseschlauch 150 cm. und Handbrause.

Grupo para borde de bañera, 4 agujeros, con tubo flexible, longitud 150 cm y ducha.

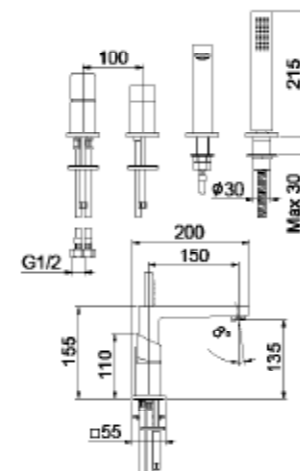

.015 Cromo / Chrome / Chromée / Verchromt / Cromo € 483,00

.560 Nero opaco / Matt black / Noir mat / Matt schwarz / Negro mate € 580,00

Collezione Primavera € 869,00

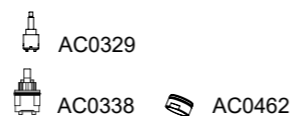

## OR850101

2,8 kg



Miscelatore monocomando per vasca esterno completo con flessibile da 150 cm, doccetta anticalcare e supporto.

Single lever bath mixer with shower set complete of hose 150 cm, handshower and holder.

Mitigeur bain-douche complet de flexible 150 cm, douchette et support mural.

Einhebelmischer Badebatterie mit Brausegarnitur bestehend aus Brauseschlauch 150 cm, Handbrause und Wandhalterung.

Monomando externo para bañera completo, con tubo flexible de 150 cm, ducha antical y soporte.

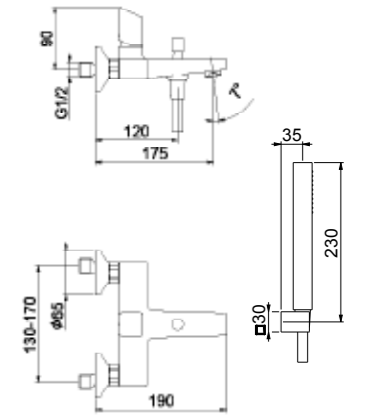

.015 Cromo / Chrome / Chromée / Verchromt / Cromo € 150,00

.560 Nero opaco / Matt black / Noir mat / Matt schwarz / Negro mate € 210,00

Collezione Primavera € 270,00



## OR870101

2,4 kg



Miscelatore monocomando per doccia esterno completo con flessibile da 150 cm, doccetta anticalcare e supporto.

Single lever shower mixer with shower set complete of hose 150 cm, handshower and holder.

Mitigeur de douche complet de flexible 150 cm, douchette et support mural.

Einhebelmischer Brausebatterie mit Brausegarnitur bestehend aus Brauseschlauch 150 cm, Handbrause und Wandhalterung.

Monomando externo para ducha completo, con tubo flexible de 150 cm, ducha antical y soporte.

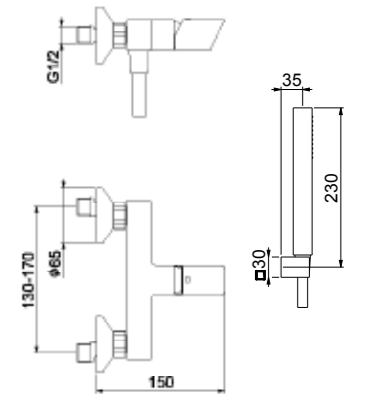

.015 Cromo / Chrome / Chromée / Verchromt / Cromo € 123,00

.560 Nero opaco / Matt black / Noir mat / Matt schwarz / Negro mate € 172,00

Collezione Primavera € 221,00

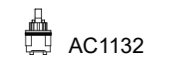

## OR870108

2,2 kg



Miscelatore monocomando per doccia esterno con attacco superiore.

Single lever shower mixer with upper connection.

Mitigeur de douche avec raccord supérieur.

Einhebelmischer Brausebatterie mit Anschluss oben.

Monomando externo para ducha con conexión superior.

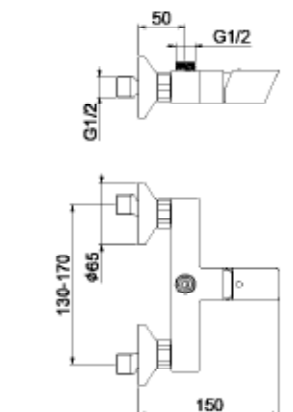

.015 Cromo / Chrome / Chromée / Verchromt / Cromo € 97,00

.560 Nero opaco / Matt black / Noir mat / Matt schwarz / Negro mate € 117,00

Collezione Primavera € 165,00



## OR880101

1 kg



Miscelatore monocomando per doccia incasso, con piastra, senza flessibile, doccetta e gancio.

Concealed single lever shower mixer with cover plate, without shower set.

Mitigeur de douche à encastrer avec rosace, sans garniture de douche.

Einhebelmischer Unterputz-Brausebatterie, mit Rosette ohne Brausegarnitur.

Monomando empotrable para ducha, con placa, sin tubo flexible, ducha ni gancho.

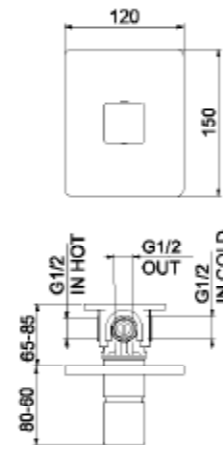

PER FINITURE CONSULTARE SEZIONE EASY BATHROOM A PAG. 260

FOR ALL AVAILABLE FINISHINGS PLEASE GO TO EASY BATHROOM P. 260

.015 Cromo / Chrome / Chromée / Verchromt / Cromo € 66,00



## OR880601

1,9 kg



Miscelatore doccia incasso con deviatore ceramico, tre uscite.

3-way built-in shower mixer with ceramic diverter.

Mitigeur douche à encastrer avec inverseur en céramique, trois sorties.

3-Weg Unterputz Duschenmischer mit Keramikumsteller.

Mezclador ducha empotrable con desviador cerámico, tres vías.

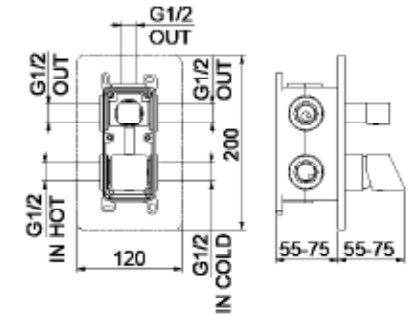

PER FINITURE CONSULTARE SEZIONE EASY BATHROOM A PAG. 260

FOR ALL AVAILABLE FINISHINGS PLEASE GO TO EASY BATHROOM P. 260

.015 Cromo / Chrome / Chromée / Verchromt / Cromo € 121,00

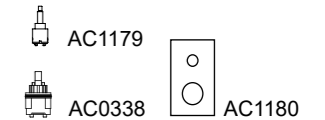

## OR860101

1,5 kg



Miscelatore monocomando per vasca incasso, con deviatore, piastra, senza flessibile doccetta e gancio di supporto.

Concealed single lever bath mixer with diverter, cover plate, without shower set.

Mitigeur bain-douche à encastrer avec inverseur, rosace, sans garniture de douche.

Einhebelmischer Unterputz-Badebatterie mit Umstellung, Rosette, ohne Brausegarnitur.

Monomando empotrable para bañera, con desviador, placa, sin tubo flexible, ducha ni gancho de soporte.

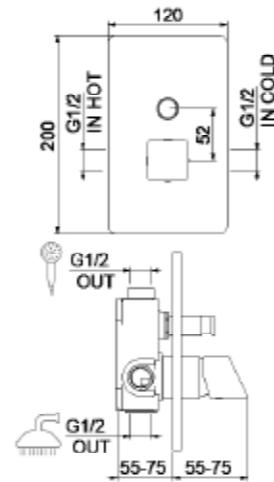

.015 Cromo / Chrome / Chromée / Verchromt / Cromo € 115,00

.560 Nero opaco / Matt black / Noir mat / Matt schwarz / Negro mate € 130,00

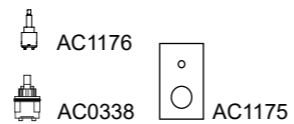

## OR860901

1,6 kg



Miscelatore doccia incasso con deviatore ceramico, due uscite.

2-way built-in shower mixer with ceramic diverter.

Mitigeur douche à encastrer avec inverseur en céramique, deux sorties.

2-Weg Unterputz Duschenmischer mit Keramikumsteller.

Mezclador ducha empotrable con desviador cerámico, dos vías.

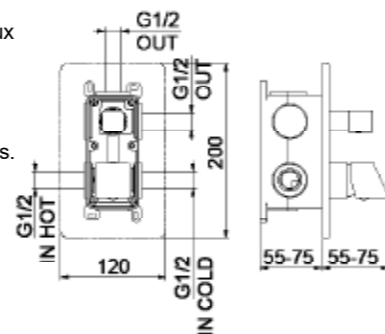

PER FINITURE CONSULTARE SEZIONE EASY BATHROOM A PAG. 260

FOR ALL AVAILABLE FINISHINGS PLEASE GO TO EASY BATHROOM P. 260

.015 Cromo / Chrome / Chromée / Verchromt / Cromo € 117,00

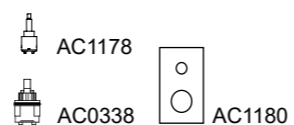

# OMBRA PLUS



Finiture / finishes / finitions / ausföhrungen / acabados

.015  
Cromo  
Chrome  
Chromée  
Verchromt  
Cromo

.560  
Nero opaco  
Matt black  
Noir mat  
Matt schwarz  
Negro mate

Collezione  
Primavera

## OP830101

1,8 kg



Miscelatore lavabo, scarico click-clack spessore regolabile, flex antitorsione cm 50 3/8" F.

One hole basin mixer, click-clack waste, antitorsion flex cm 50 3/8" F.

Mitigeur lavabo, vidage click-clack, flexibles antitorsion cm 50 3/8" F.

Einhebelmischer Waschtischbatterie mit up & down Ablaufgarnitur, mit flex. Anschlussschläuchen cm 50 3/8" F.

Monomando para lavabo con valvula click-clack, tubo flexible inoxidable de 50 cm, empalme 3/8" F.

- .015 Cromo / Chrome / Chromée / Verchromt / Cromo € 102,00
- .560 Nero opaco / Matt black / Noir mat / Matt schwarz / Negro mate € 142,00
- Collezione Primavera € 186,00

OP830102

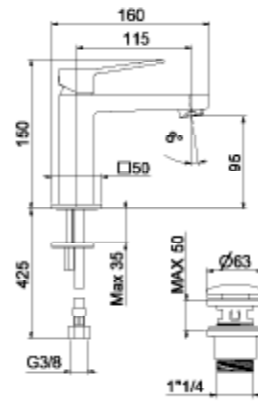

AC1132 AC0462

## OP833601

1,8 kg



Miscelatore lavabo medio, testa cieca, flex antitorsione cm 50 3/8" F.

One hole medium basin mixer, without pop up waste, antitorsion flex cm 50 3/8" F.

Mitigeur lavabo, sans vidage, flexibles antitorsion cm 50 3/8" F.

Einhebelmischer Waschtischbatterie ohne up & down Ablaufgarnitur, mit flex. Anschlussschläuchen cm 50 3/8" F.

Monomando para lavabo sin valvula click-clack, tubo flexible inoxidable de 50 cm, empalme 3/8" F.

- .015 Cromo / Chrome / Chromée / Verchromt / Cromo € 107,00
- .560 Nero opaco / Matt black / Noir mat / Matt schwarz / Negro mate € 128,00
- Collezione Primavera € 169,00

OP833602

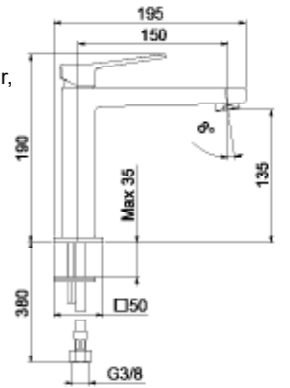

AC1132 AC0462

## OP830201

1,6 kg



Miscelatore lavabo, testa cieca, flex antitorsione cm 50 3/8" F.

One hole basin mixer, without pop up waste, antitorsion flex cm 50 3/8" F.

Mitigeur lavabo, sans vidage, flexibles antitorsion cm 50 3/8" F.

Einhebelmischer Waschtischbatterie ohne up & down Ablaufgarnitur, mit flex. Anschlussschläuchen cm 50 3/8" F.

Monomando para lavabo sin valvula click-clack, tubo flexible inoxidable de 50 cm, empalme 3/8" F.

- .015 Cromo / Chrome / Chromée / Verchromt / Cromo € 90,00
- .560 Nero opaco / Matt black / Noir mat / Matt schwarz / Negro mate € 108,00
- Collezione Primavera € 145,00

OP830202

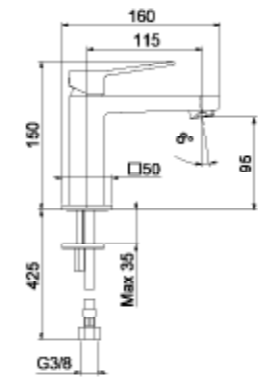

AC1132 AC0462

## OP830401

2,7 kg



Miscelatore lavabo alto, scarico click-clack spessore regolabile, flex antitorsione cm 70 3/8" F.

One hole high basin mixer, click-clack waste, antitorsion flex cm 70 3/8" F.

Mitigeur lavabo haut, vidage click-clack, flexibles antitorsion cm 70 3/8" F.

Einhebelmischer Waschtischbatterie, mit hoher Ausführung, mit up & down Ablaufgarnitur, mit Flex. Anschlussschläuchen cm 70 3/8" F.

Monomando para lavabo alto con valvula click-clack, tubo flexible

- .015 Cromo / Chrome / Chromée / Verchromt / Cromo € 185,00
- .560 Nero opaco / Matt black / Noir mat / Matt schwarz / Negro mate € 259,00
- Collezione Primavera € 323,00

OP830402

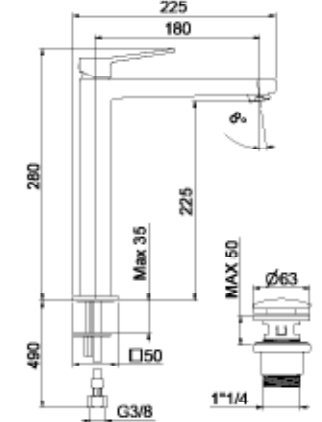

AC1132 AC0462

## OP833101

2 kg



Miscelatore lavabo medio, scarico click-clack spessore regolabile, flex antitorsione cm 50 3/8" F.

One hole medium basin mixer, click-clack waste, antitorsion flex cm 50 3/8" F.

Mitigeur lavabo, vidage click-clack, flexibles antitorsion cm 50 3/8" F.

Einhebelmischer Waschtischbatterie mit up & down Ablaufgarnitur, mit flex. Anschlussschläuchen cm 50 3/8" F.

Monomando para lavabo con valvula click-clack, tubo flexible

- .015 Cromo / Chrome / Chromée / Verchromt / Cromo € 117,00
- .560 Nero opaco / Matt black / Noir mat / Matt schwarz / Negro mate € 164,00
- Collezione Primavera € 211,00

OP833102

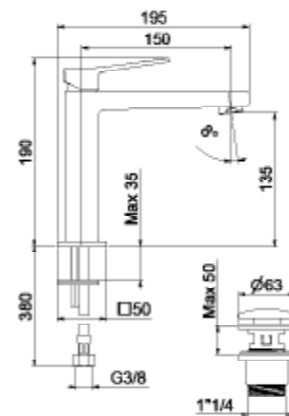

AC1132 AC0462

## OP833701

2,5 kg



Miscelatore lavabo alto, testa cieca, flex antitorsione cm 70 3/8" F.

One hole high basin mixer, without pop up waste, antitorsion flex cm 70 3/8" F.

Mitigeur lavabo haut, sans vidage, flexibles antitorsion cm 70 3/8" F.

Einhebelmischer Waschtischbatterie ohne up & down Ablaufgarnitur, mit flex. Anschlussschläuchen cm 70 3/8" F.

Monomando para lavabo sin valvula click-clack, tubo flexible inoxidable de 70 cm, empalme 3/8" F.

- .015 Cromo / Chrome / Chromée / Verchromt / Cromo € 174,00
- .560 Nero opaco / Matt black / Noir mat / Matt schwarz / Negro mate € 209,00
- Collezione Primavera € 264,00

OP833702

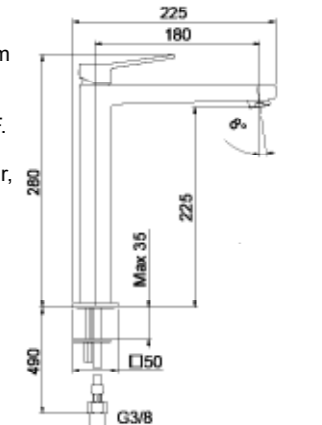

AC1132 AC0462

## OP840101

1,7 kg



Miscelatore bidet, scarico click-clack spessore regolabile, flex antitorsione cm 50 3/8" F.

One hole bidet mixer, click-clack waste, antitorsion flex cm 50 3/8" F.

Mitigeur bidet, vidage click-clack, flexibles antitorsion cm 50 3/8" F.

Einhebelmischer Bidetbatterie mit up & down Ablaufgarnitur 1" 1/4, mit flex. Anschlussschläuchen cm 50 3/8" F.

Monomando para bidé con desagüe up & down, tubo flexible inoxidable de 50 cm, empalme 3/8" F.

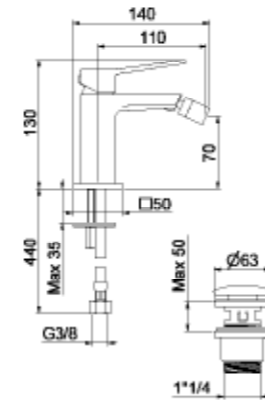

.015 Cromo / Chrome / Chromée / Verchromt / Cromo € 97,00

.560 Nero opaco / Matt black / Noir mat / Matt schwarz / Negro mate € 136,00

Collezione Primavera € 176,00

AC1132 AC0990

OP840102

## OP840201

1,5 kg



Miscelatore bidet, testa cieca, flex antitorsione cm 50 3/8" F.

One hole bidet mixer, without pop up waste, antitorsion flex cm 50 3/8" F.

Mitigeur bidet, sans vidage, flexibles antitorsion cm 50 3/8" F.

Einhebelmischer Bidetbatterie ohne up & down Ablaufgarnitur, mit flex. Anschlussschläuchen cm 50 3/8" F.

Monomando para bidet sin valvula click-clack, tubo flexible inoxidable de 50 cm, empalme 3/8" F.

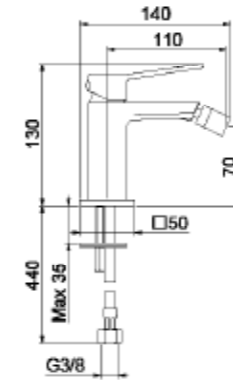

.015 Cromo / Chrome / Chromée / Verchromt / Cromo € 85,00

.560 Nero opaco / Matt black / Noir mat / Matt schwarz / Negro mate € 102,00

Collezione Primavera € 136,00

AC1132 AC0990

OP840202

## OP830701

2 kg



Miscelatore per lavabo a due fori.

2-holes washbasin mixer.

Mitigeur de lavabo 2-trous

2-Loch-Einhebelmischer.

Grifo bimando para lavabo, 2 agujeros.

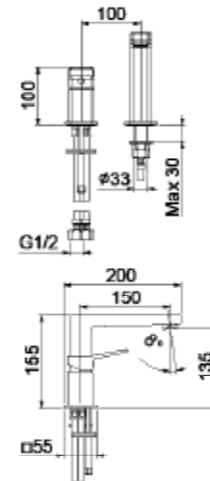

.015 Cromo / Chrome / Chromée / Verchromt / Cromo € 194,00

.560 Nero opaco / Matt black / Noir mat / Matt schwarz / Negro mate € 234,00

Collezione Primavera € 349,00

AC0338 AC0462

## OP750102

2,6 kg



Batteria per lavabo a tre fori completa con scarico up & down.

3-holes washbasin mixer with up & down pop-up waste.

Mélangeur de lavabo 3-trous bec fixe avec vidage up & down.

3-Loch-Waschtischbatterie mit up & down Ablaufgarnitur.

Grifo bimando para lavabo de repisa, 3 agujeros, desagüe up & down.

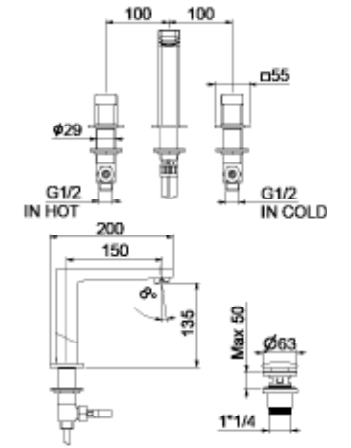

.015 Cromo / Chrome / Chromée / Verchromt / Cromo € 338,00

.560 Nero opaco / Matt black / Noir mat / Matt schwarz / Negro mate € 408,00

Collezione Primavera € 507,00

AC0331 AC0332 AC0462

## OP830606

2 kg



Miscelatore monocomando per lavabo incasso muro, con piastra orizzontale, senza scarico e flessibili.

Concealed single lever washbasin mixer, horizontal cover plate, without pop-up waste and flex hoses.

Mitigeur de lavabo à encastrer, rosace horizontale, sans vidage et flexibles.

Einhebelmischer Unterputz-Waschtischbatterie waagerechte Rosette, ohne Ablaufgarnitur und flex. Anschlussschläuchen.

Monomando empotrable para lavabo de pared, con placa horizontal, sin desagüe ni tubos flexibles.

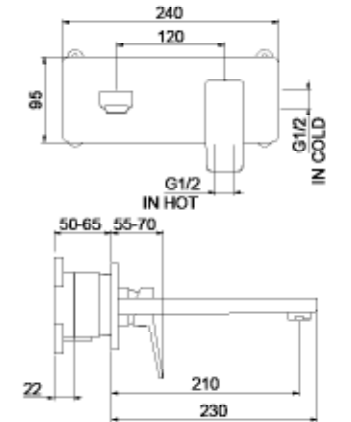

PER FINITURE CONSULTARE SEZIONE EASY BATHROOM A PAG. 260

FOR ALL AVAILABLE FINISHINGS PLEASE GO TO EASY BATHROOM P. 260

.015 Cromo / Chrome / Chromée / Verchromt / Cromo € 176,00

AC0338 AC0462

## OP830609

2 kg



Miscelatore monocomando per lavabo incasso muro, con piastre separate, senza scarico e flessibili.

Concealed single lever washbasin mixer, with cover plates, without pop-up waste and flex hoses.

Mitigeur de lavabo à encastrer, avec 2 rosaces, sans vidage et flexibles.

Einhebelmischer Unterputz-Waschtischbatterie, mit getrennten Platten, ohne Ablaufgarnitur und flex Anschlussschläuchen.

Monomando empotrable para lavabo de pared, con 2 placas, sin desagüe ni tubos flexibles.

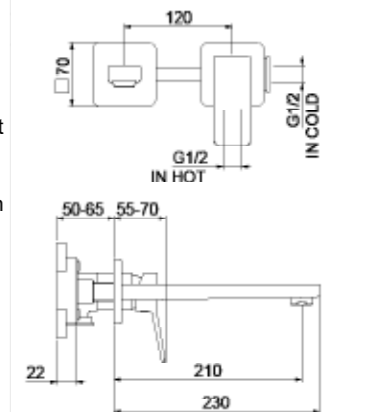

PER FINITURE CONSULTARE SEZIONE EASY BATHROOM A PAG. 260

FOR ALL AVAILABLE FINISHINGS PLEASE GO TO EASY BATHROOM P. 260

.015 Cromo / Chrome / Chromée / Verchromt / Cromo € 166,00

AC0338 AC0462

## OP851101

8,5 kg

Miscelatore monocomando per vasca a pavimento con flessibile, doccetta.

Single lever floor bath mixer with flexible hose, handshower.

Mitigeur baignoire au sol avec flexible, douchette.

Einhebelmischer Stand-Badebatterie mit Brauseschlauch, Handbrause.

Monomando para bañera de pie, con flexible y ducha.

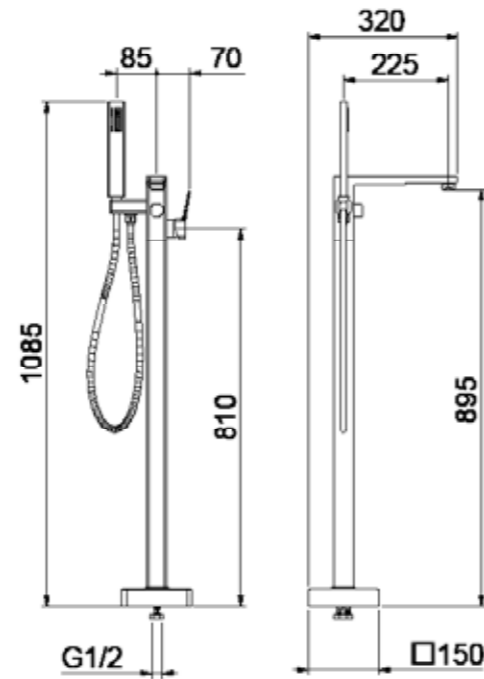
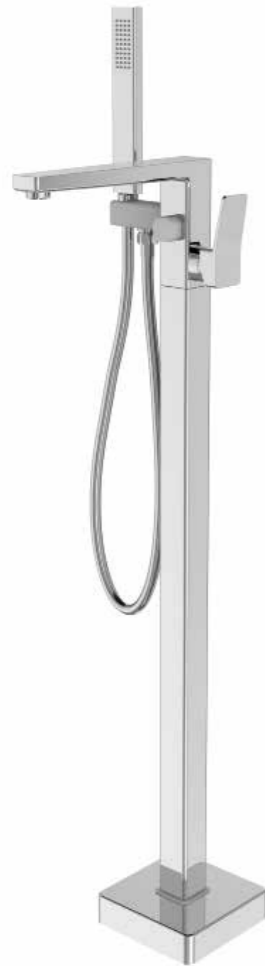

- .015 Cromo / Chrome / Chromée / Verchromt / Cromo € 1.038,00
- .560 Nero opaco / Matt black / Noir mat / Matt schwarz / Negro mate € 1.453,00
- Collezione Primavera € 1.868,00



## OP730101

5 kg

Gruppo per bordo vasca 4 fori completo con flessibile da 150 cm e doccetta.

4-holes deck mounted bath mixer complete of hose 150 cm and handshower.

Mitigeur bain-douche 4-trous, flexible 150 cm et douchette.

4-Loch-Wannenrandarmatur mit Metallbrauseschlauch 150 cm. und Handbrause.

Grupo para borde de bañera, 4 agujeros, con tubo flexible, longitud 150 cm y ducha.

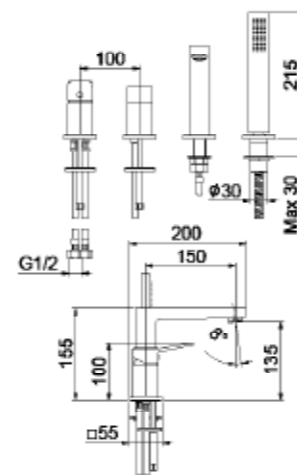

- .015 Cromo / Chrome / Chromée / Verchromt / Cromo € 483,00
- .560 Nero opaco / Matt black / Noir mat / Matt schwarz / Negro mate € 580,00
- Collezione Primavera € 869,00

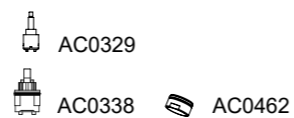

## OP850101

2,8 kg

Miscelatore monocomando per vasca esterno completo con flessibile da 150 cm, doccetta anticalcare e supporto.

Single lever bath mixer with shower set complete of hose 150 cm, handshower and holder.

Mitigeur bain-douche complet de flexible 150 cm, douchette et support mural.

Einhebelmischer Badebatterie mit Brausegarnitur bestehend aus Brauseschlauch 150 cm, Handbrause und Wandhalterung.

Monomando externo para bañera completo, con tubo flexible de 150 cm, ducha antical y soporte.

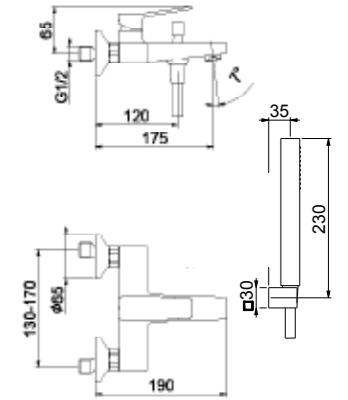

- .015 Cromo / Chrome / Chromée / Verchromt / Cromo € 150,00
- .560 Nero opaco / Matt black / Noir mat / Matt schwarz / Negro mate € 210,00
- Collezione Primavera € 270,00

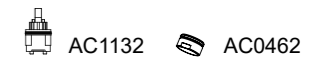

## OP870101

2,4 kg

Miscelatore monocomando per doccia esterno completo con flessibile da 150 cm, doccetta anticalcare e supporto.

Single lever shower mixer with shower set complete of hose 150 cm, handshower and holder.

Mitigeur de douche complet de flexible 150 cm, douchette et support mural.

Einhebelmischer Brausebatterie mit Brausegarnitur bestehend aus Brauseschlauch 150 cm, Handbrause und Wandhalterung.

Monomando externo para ducha completo, con tubo flexible de 150 cm, ducha antical y soporte.

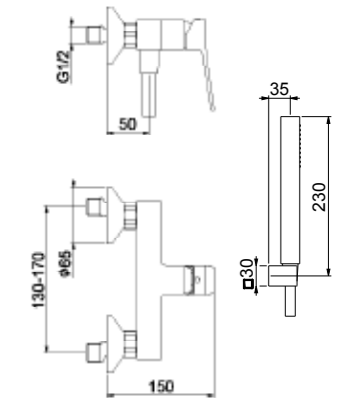

- .015 Cromo / Chrome / Chromée / Verchromt / Cromo € 123,00
- .560 Nero opaco / Matt black / Noir mat / Matt schwarz / Negro mate € 172,00
- Collezione Primavera € 221,00



## OP870108

2,2 kg

Miscelatore monocomando per doccia esterno con attacco superiore.

Single lever shower mixer with upper connection.

Mitigeur de douche avec raccord supérieur.

Einhebelmischer Brausebatterie mit Anschluss oben.

Monomando externo para ducha con conexión superior.

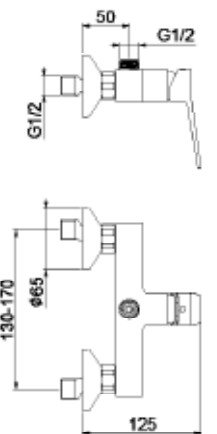

- .015 Cromo / Chrome / Chromée / Verchromt / Cromo € 97,00
- .560 Nero opaco / Matt black / Noir mat / Matt schwarz / Negro mate € 117,00
- Collezione Primavera € 165,00



## OP880101

1 kg



Miscelatore monocomando per doccia incasso, con piastra, senza flessibile, doccetta e gancio.

Concealed single lever shower mixer with cover plate, without shower set.

Mitigeur de douche à encastrer avec rosace, sans garniture de douche.

Einhebelmischer Unterputz-Brausebatterie, mit Rosette ohne Brausegarnitur.

Monomando empotrable para ducha, con placa, sin tubo flexible, ducha ni gancho.

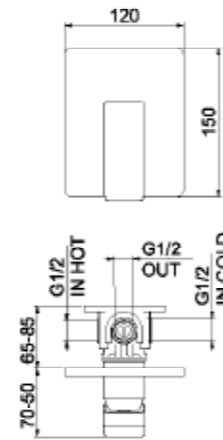

PER FINITURE CONSULTARE SEZIONE EASY BATHROOM A PAG. 260

FOR ALL AVAILABLE FINISHINGS PLEASE GO TO EASY BATHROOM P. 260

.015 Cromo / Chrome / Chromée / Verchromt / Cromo € 66,00



## OP880601

1,9 kg



Miscelatore doccia incasso con deviatore ceramico, tre uscite.

3-way built-in shower mixer with ceramic diverter.

Mitigeur douche à encastrer avec inverseur en céramique, trois sorties.

3-Weg Unterputz Duschenmischer mit Keramikumsteller.

Mezclador ducha empotrable con desviador cerámico, tres vías.

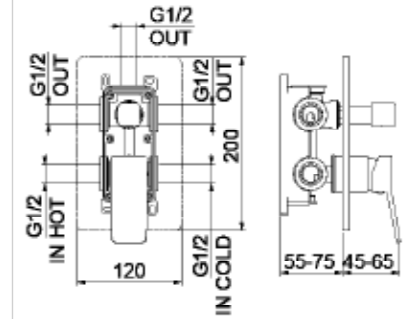

PER FINITURE CONSULTARE SEZIONE EASY BATHROOM A PAG. 260

FOR ALL AVAILABLE FINISHINGS PLEASE GO TO EASY BATHROOM P. 260

.015 Cromo / Chrome / Chromée / Verchromt / Cromo € 121,00

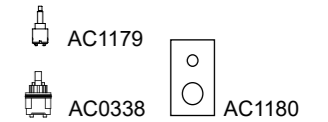

## OP860101

1,5 kg



Miscelatore monocomando per vasca incasso, con deviatore, piastra, senza flessibile doccetta e gancio di supporto.

Concealed single lever bath mixer with diverter, cover plate, without shower set.

Mitigeur bain-douche à encastrer avec inverseur, rosace, sans garniture de douche.

Einhebelmischer Unterputz-Badebatterie mit Umstellung, Rosette, ohne Brausegarnitur.

Monomando empotrable para bañera, con desviador, placa, sin tubo flexible, ducha ni gancho de soporte.

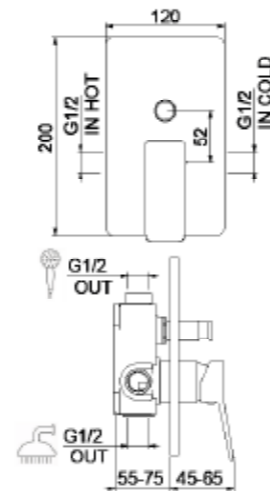

.015 Cromo / Chrome / Chromée / Verchromt / Cromo € 115,00

.560 Nero opaco / Matt black / Noir mat / Matt schwarz / Negro mate € 130,00

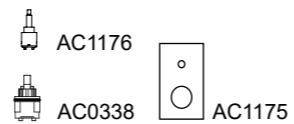

## OP860901

1,6 kg



Miscelatore doccia incasso con deviatore ceramico, due uscite.

2-way built-in shower mixer with ceramic diverter.

Mitigeur douche à encastrer avec inverseur en céramique, deux sorties.

2-Weg Unterputz Duschenmischer mit Keramikumsteller.

Mezclador ducha empotrable con desviador cerámico, dos vías.

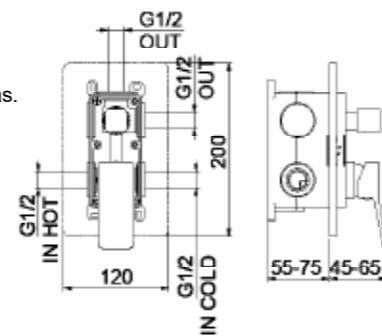

PER FINITURE CONSULTARE SEZIONE EASY BATHROOM A PAG. 260

FOR ALL AVAILABLE FINISHINGS PLEASE GO TO EASY BATHROOM P. 260

.015 Cromo / Chrome / Chromée / Verchromt / Cromo € 117,00

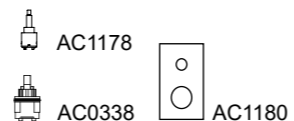



## ONE SERIES

Rivoluzionaria, unica.

One Series è la nuova collezione di rubinetteria Webert nata da un processo produttivo innovativo, che per la prima volta integra le straordinarie potenzialità dell'additive manufacturing nell'interior design.

Punto di arrivo di uno studio accurato, ridefinisce i limiti nel design e nella manifattura della rubinetteria, arricchendo di nuovi stimoli il vivere quotidiano.

Revolutionary, unique.

One Series is the new tap Webert collection born from an innovative production process, that for the first time integrates the extraordinary potential of additive manufacturing in interior design.

End point of an accurate study, redefines the limits in design and manufacturing of taps, enriching daily life with new boost.



*Additive  
Manufacturing*

# Innovative Process

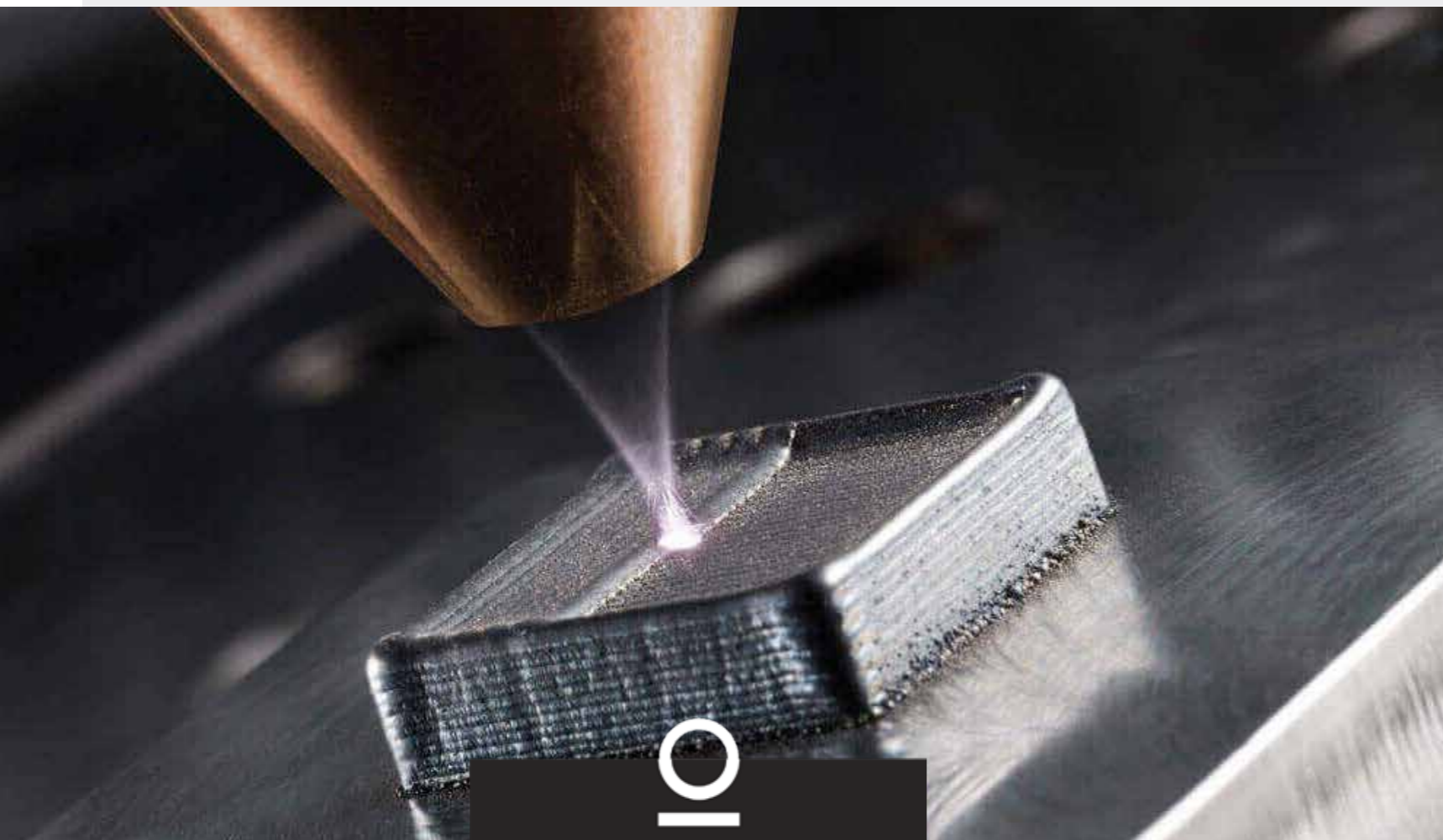

**O**  
ONE SERIES

## Acciaio Inox 316L Sano, duraturo, atossico

L'acciaio inossidabile non contiene tracce di piombo e non rilascia nichel, materiali che possono essere causa di allergie e arrecare danni alla salute. L'acciaio inossidabile viene trattato solo meccanicamente, lucidato o spazzolato per conferire la sua naturale lucentezza e bellezza, non subisce nessun processo galvanico di cromatura o artificiale, procedimenti chimici che possono essere causa di inquinamento.

L'acciaio inossidabile garantisce una eccezionale durata per la sua resistenza sia meccanica che chimica.

In ambienti ad elevata aggressività l'acciaio mantiene inalterate le proprie caratteristiche di inossidabilità garantendo durata e funzionalità.

L'acciaio AISI 316L risulta il migliore in assoluto per inossidabilità, stabilità della struttura e durata, possedendo le migliori caratteristiche per la gestione dell'acqua potabile.

## Stainless steel 316L Healthy, long-lasting, atoxic

Stainless steel does not contain traces of lead and does not release any nickel, both substances that can cause allergies and harm to your health. Stainless steel is only treated mechanically, polished or brushed to give it its natural light and beauty, it does not undergo any galvanizing chromium process, chemical processes that can be the cause of pollution.

Stainless steel guarantees an exceptional life span, because of its solidity, both mechanical and chemical. The characteristics of stainless steel, and AISI 316L in particular, remain the same also in hard environments guaranteeing long-lasting performance over the years.

AISI 316L Steel has the best characteristics in terms of stain resistance, durability and solidity, and guarantee drinking water.

OX  
ONE-X



OX830101.441  
Miscelatore lavabo.  
One hole basin mixer.

Design: Massimiliano Settimelli



OX830401.441  
Miscelatore lavabo alto.  
One hole basin mixer, high body.



Un connubio di modernità ed eleganza senza tempo, l'acciaio, un materiale nobile ed eterno, associato a un senso di freddezza e austerità è reso più organico e caldo dalla finitura sabbia-ta. Le forme nette e più spigolose della bocca si accordano perfettamente a quelle più morbide del corpo come in un moderno edificio o un'installazione artistica. Ideale per un ambiente bagno che non cerca compromessi, elegante nella sua semplicità, innovativo, moderno, risoluto...

A union of modernity and timeless elegance, steel, a noble and eternal material, associated with a sense of coldness and austerity, is now more organic and warmer. The sharp and angular shapes of the spout perfectly match the softness of the body as in a modern building or artwork. It is ideal for a bathroom that does not seek compromises, elegant in its simplicity, innovative, stylish, resolute...



Finiture / finishes / finitions / ausführungen / acabados

.015	.441	.741
Acciaio + cromo	Acciaio + nero	Acciaio + bianco
Steel + chrome	Steel + black	Steel + white
Acier + chromée	Acier + noir	Acier + blanc
Stahl + verchromt	Stahl + Schwarz	Stahl + Weiss
Acero + cromado	Acero + negro	Acero + blanco

OX830606.441  
Miscelatore lavabo a muro.  
Wall basin mixer.

## OX830101

 Kg 1,3  
Box pcs 8



Miscelatore monocomando per lavabo con scarico up & down, con flex inox cm 50 att. 3/8" F.

Single lever washbasin mixer with up & down pop-up waste, with 3/8" F flex. hoses cm 50.

Mitigeur de lavabo avec vidage up & down, flexibles d'alimentation cm 50 3/8" F.

Einhebelmischer Waschtischbatterie mit up & down Ablaufgarnitur, mit flex. Anschlussschläuchen cm 50 3/8" F.

Monomando para lavabo con valvula click-clack, tubo flexible inoxidable de 50 cm, empalme 3/8" F.

.015 Acciaio + cromo / Steel + chrome / Acier + chromée / Stahl + verchromt / Acero + cromado € 1.130,00

.441 Acciaio + nero / Steel + black / Acier + noir / Stahl + Schwarz / Acero + negro € 1.180,00

.741 Acciaio + bianco / Steel + white / Acier + blanc / Stahl + Weiss / Acero + blanco € 1.180,00

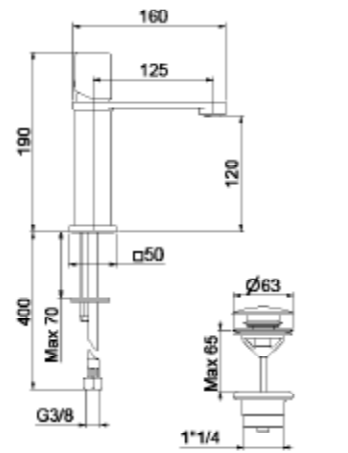

 AC0470000  Ø 25 mm AC0368000

 OX830102

## OX830401

 Kg 2,8  
Box pcs 5



Miscelatore monocomando per lavabo alto con scarico up & down, flex inox cm 70 att. 3/8" F.

High single lever washbasin mixer with up & down pop-up waste, with 3/8" flex. hoses 70 cm.

Mitigeur de lavabo haut avec vidage up & down, flexibles d'alimentation cm 70 3/8" F.

Einhebelmischer Waschtischbatterie, mit hoher Ausführung, mit up & down Ablaufgarnitur, mit Flex. Anschlussschläuchen cm 70 3/8" F.

Monomando para lavabo alto con valvula click-clack, tubo flexible inoxidable de 70 cm, empalme 3/8" F.

.015 Acciaio + cromo / Steel + chrome / Acier + chromée / Stahl + verchromt / Acero + cromado € 1.600,00

.441 Acciaio + nero / Steel + black / Acier + noir / Stahl + Schwarz / Acero + negro € 1.650,00

.741 Acciaio + bianco / Steel + white / Acier + blanc / Stahl + Weiss / Acero + blanco € 1.650,00

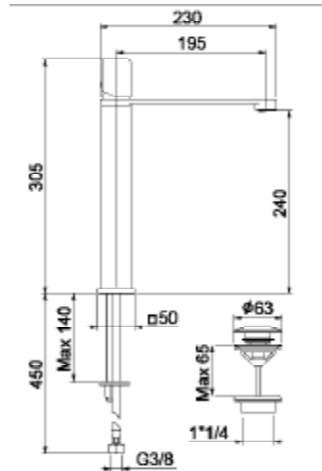

 AC0470000  Ø 25 mm AC0368000

 OX830402

## OX840101

 Kg 1,3  
Box pcs 8



Miscelatore monocomando per bidet con scarico up & down, con flex inox cm 50 att. 3/8" F.

Single lever bidet mixer with up & down pop-up waste, with 3/8" F flex. hoses cm 50.

Mitigeur de bidet avec vidage up & down, flexibles d'alimentation cm 50 3/8" F.

Einhebelmischer Bidetbatterie mit up & down Ablaufgarnitur 1" 1/4, mit flex. Anschlussschläuchen cm 50 3/8" F.

Monomando para bidé con desagüe up & down, tubo flexible inoxidable de 50 cm, empalme 3/8" F.

.015 Acciaio + cromo / Steel + chrome / Acier + chromée / Stahl + verchromt / Acero + cromado € 920,00

.441 Acciaio + nero / Steel + black / Acier + noir / Stahl + Schwarz / Acero + negro € 970,00

.741 Acciaio + bianco / Steel + white / Acier + blanc / Stahl + Weiss / Acero + blanco € 970,00

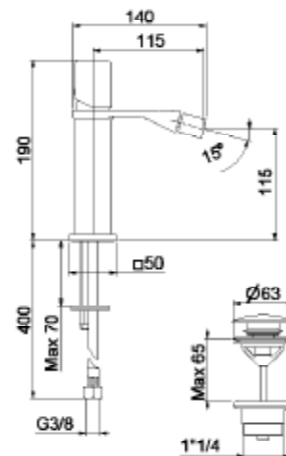

 AC0464015  Ø 25 mm AC0368000

 OX840102

## OX830611

 Kg 1,6  
Box pcs 8



Miscelatore monocomando per lavabo incasso muro, con piastre separate, senza scarico e flessibili.

Concealed single lever washbasin mixer, with 2 cover plates, without pop-up waste and flex hoses.

Mitigeur de lavabo à encastrer, avec 2 rosaces, sans vidage et flexibles.

Einhebelmischer Unterputz-Waschtischbatterie, mit getrennten Platten, ohne Ablaufgarnitur und flex Anschlussschläuchen.





Monomando empotrable para lavabo de pared, con 2 placas, sin desagüe ni tubos flexibles.

.015 Acciaio + cromo / Steel + chrome / Acier + chromée / Stahl + verchromt / Acero + cromado € 1.850,00

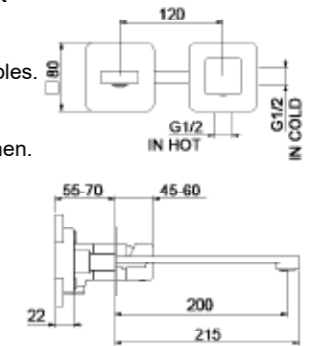
.441 Acciaio + nero / Steel + black / Acier + noir / Stahl + Schwarz / Acero + negro € 1.950,00

.741 Acciaio + bianco / Steel + white / Acier + blanc / Stahl + Weiss / Acero + blanco € 1.950,00



 AC1067  AC1068  
 AC0470000  Ø 35 mm AC0338000

## OX830606

 Kg 1,6  
Box pcs 8



Miscelatore monocomando per lavabo incasso muro, con piastra, senza scarico e flessibili.

Concealed single lever washbasin mixer, with cover plate, without pop-up waste and flex hoses.

Mitigeur de lavabo à encastrer, avec rosace, sans vidage et flexibles.

Einhebelmischer Unterputz-Waschtischbatterie, mit Rosette, ohne Ablaufgarnitur und flex Anschlussschläuchen.



Monomando empotrable para lavabo de pared, con placa, sin desagüe ni tubos flexibles.

.015 Acciaio + cromo / Steel + chrome / Acier + chromée / Stahl + verchromt / Acero + cromado € 1.850,00

.441 Acciaio + nero / Steel + black / Acier + noir / Stahl + Schwarz / Acero + negro € 1.950,00

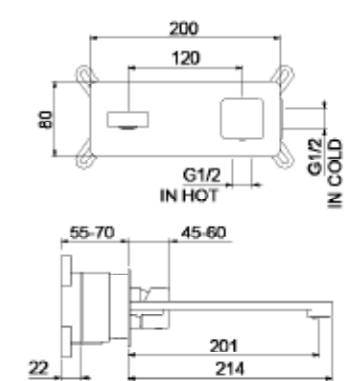
.741 Acciaio + bianco / Steel + white / Acier + blanc / Stahl + Weiss / Acero + blanco € 1.950,00



 AC1069  
 AC0470000  Ø 35 mm AC0338000

## OX880101

 Kg 0,8  
Box pcs 24



Miscelatore monocomando per doccia incasso, con piastra, senza flessibile, doccia e gancio.

Concealed single lever shower mixer with cover plate, without shower set.

Mitigeur de douche à encastrer avec rosace, sans garniture de douche.

Einhebelmischer Unterputz-Brausebatterie, mit Rosette ohne Brausegarnitur.

Monomando empotrable para ducha, con placa, sin tubo flexible, ducha ni gancho.

.015 Cromo / Chrome / Chromée / Verchromt / Cromado € 144,00

.560 Nero opaco / Matt black / Noir mat / Matt Schwarz / Negro mate € 195,00

.740 Bianco opaco / Matt white / Blanc mat / Matt Weiss / Blanco mate € 195,00

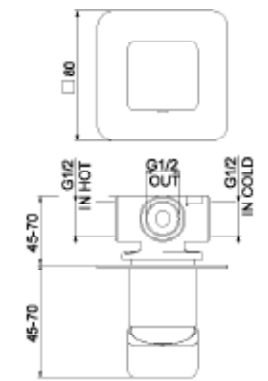

 AC1067  Ø 35 mm AC0338000

## OX860101

Kg 2,2  
Box pcs 12



Miscelatore monocomando per vasca incasso con deviatore, senza flessibile, doccetta e gancio di supporto.

Concealed single lever bath mixer with diverter, without shower set.

Mitigeur bain-douche à encastrer avec inverseur, sans garniture de douche.

Einhebelmischer Unterputz-Duschkörper mit Umstellung, ohne Brausegarnitur.

Monomando empotrable para bañera, con desviador; sin tubo flexible, rociador ni soporte.

- .015 Cromo / Chrome / Chromée / Verchromt / Cromado € 300,00
- .560 Nero opaco / Matt black / Noir mat / Matt Schwarz / Negro mate € 410,00
- .740 Bianco opaco / Matt white / Blanc mat / Matt Weiss / Blanco mate € 410,00

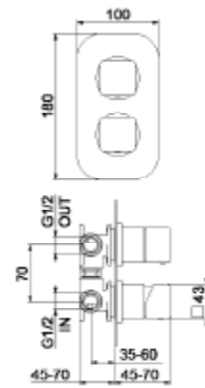

Ø 35 mm  
AC0338000

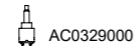

AC0329000

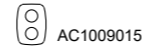

AC1009015

## AC1073

Kg 0,9  
Box pcs 12



Bocca d'erogazione senza deviatore per vasca incasso.

Spout for concealed bath mixer.

Bec pour mitigeur bain/douche encastré.

Gussauslauf für Unterputz-Badebatterie.

Boca de erogación sin desviador para bañera empotrable.

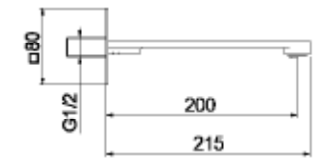

- .015 Acciaio + cromo / Steel + chrome / Acier + chromée / Stahl + verchromt / Acero + cromado € 1.700,00
- .441 Acciaio + nero / Steel + black / Acier + noir / Stahl + Schwarz / Acero + negro € 1.750,00
- .741 Acciaio + bianco / Steel + white / Acier + blanc / Stahl + Weiss / Acero + blanco € 1.800,00

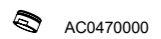

AC0470000

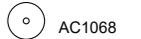

AC1068

## OX850101

Kg 3,5  
Box pcs 5



Miscelatore monocomando per vasca esterno completo con flessibile da 150 cm, doccetta anticalcare e supporto.

Single lever bath mixer with shower set complete of hose 150 cm, handshower and holder.

Mitigeur bain-douche complet de flexible 150 cm, douchette et support mural.

Einhebelmischer Badebatterie mit Brausegarnitur bestehend aus Brauseschlauch 150 cm, Handbrause und Wandhalterung.

Monomando externo para bañera completo, con tubo flexible de 150 cm, ducha a prueba de incrustaciones y soporte.

- .015 Acciaio + cromo / Steel + chrome / Acier + chromée / Stahl + verchromt / Acero + cromado € 1.700,00
- .441 Acciaio + nero / Steel + black / Acier + noir / Stahl + Schwarz / Acero + negro € 1.800,00
- .741 Acciaio + bianco / Steel + white / Acier + blanc / Stahl + Weiss / Acero + blanco € 1.800,00

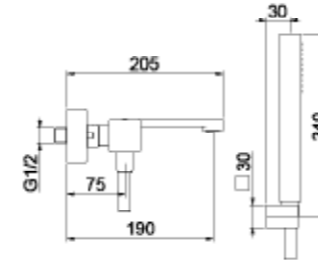
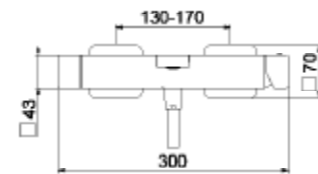

Ø 35 mm  
AC0338000



AC0470000

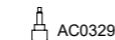

AC0329

## OX870102

Kg 2,6  
Box pcs 12



Miscelatore monocomando per doccia esterno, senza flessibile, doccetta e gancio di supporto.

Single lever shower mixer without shower set.

Mitigeur de douche sans garniture de douche.

Einhebelmischer Brausebatterie ohne Brausegarnitur.

Monomando externo para ducha, sin tubo flexible, ducha ni gancho de soporte.

- .015 Cromo / Chrome / Chromée / Verchromt / Cromado € 260,00
- .560 Nero opaco / Matt black / Noir mat / Matt Schwarz / Negro mate € 336,00
- .740 Bianco opaco / Matt white / Blanc mat / Matt Weiss / Blanco mate € 336,00

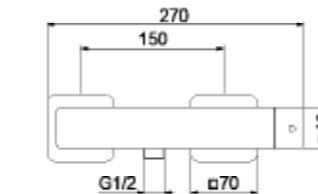

Ø 35 mm  
AC0338000



ONE-B



NB830101.441  
Miscelatore lavabo.  
One hole basin mixer.

Design: Massimiliano Settimelli



NB850101.441  
Miscelatore vasca.  
Bath mixer.

Finiture / finishes / finitions / ausfuehrungen / acabados

.015	.441	.741
Acciaio + cromo	Acciaio + nero	Acciaio + bianco
Steel + chrome	Steel + black	Steel + white
Acier + chromée	Acier + noir	Acier + blanc
Stahl + verchromt	Stahl + Schwarz	Stahl + Weiss
Acero + cromado	Acero + negro	Acero + blanco



**Come un tessuto di metallo,**

One-B evoca uno straordinario senso di leggerezza e movimento a tal punto da trasformarsi in una vera e propria scultura di Arte Cinetica che conferisce all'ambiente bagno un senso di assoluta novità. Una lama di acciaio leggera e fluida piegata intorno ad un cilindro, così avvolgente, da sembrare un tessuto morbido e sottile.

**Like a metal fabric,**

One-B evokes an extraordinary lightness and motion, turning into a real sculpture of Kinetic art that gives the bathroom a sense of absolute novelty. A light and fluid steel blade embracing a cylinder recalls a soft and thin fabric.

## NB830101

 Kg 1,3  
Box pcs 8



Miscelatore monocomando per lavabo con scarico up & down, con flex inox cm 50 att. 3/8" F.

Single lever washbasin mixer with up & down pop-up waste, with 3/8" F flex. hoses cm 50.

Mitigeur de lavabo avec vidage up & down, flexibles d'alimentation cm 50 3/8" F.

Einhebelmischer Waschtischbatterie mit up & down Ablaufgarnitur, mit flex. Anschlussschläuchen cm 50 3/8" F.

Monomando para lavabo con valvula click-clack, tubo flexible inoxidable de 50 cm, empalme 3/8" F.

.015 Acciaio + cromo / Steel + chrome / Acier + chromée / Stahl + verchromt / Acero + cromado € 825,00

.441 Acciaio + nero / Steel + black / Acier + noir / Stahl + Schwarz / Acero + negro € 855,00

.741 Acciaio + bianco / Steel + white / Acier + blanc / Stahl + Weiss / Acero + blanco € 855,00

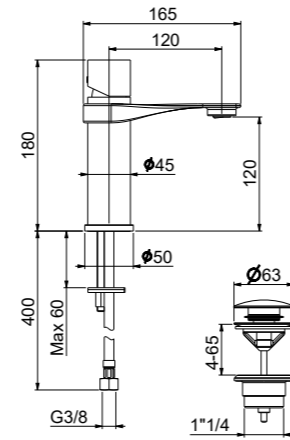

 AC0470000  Ø 25 mm  
AC0368000

 NB830102

## NB830401

 Kg 2,8  
Box pcs 5



Miscelatore monocomando per lavabo alto con scarico up & down, flex inox cm 70 att. 3/8" F.

High single lever washbasin mixer with up & down pop-up waste, with 3/8" flex. hoses 70 cm.

Mitigeur de lavabo haut avec vidage up & down, flexibles d'alimentation cm 70 3/8" F.

Einhebelmischer Waschtischbatterie, mit hoher Ausführung, mit up & down Ablaufgarnitur, mit Flex. Anschlussschläuchen cm 70 3/8" F.



Monomando para lavabo alto con valvula click-clack, tubo flexible inoxidable de 70 cm, empalme 3/8" F.

.015 Acciaio + cromo / Steel + chrome / Acier + chromée / Stahl + verchromt / Acero + cromado € 1.500,00

.441 Acciaio + nero / Steel + black / Acier + noir / Stahl + Schwarz / Acero + negro € 1.550,00

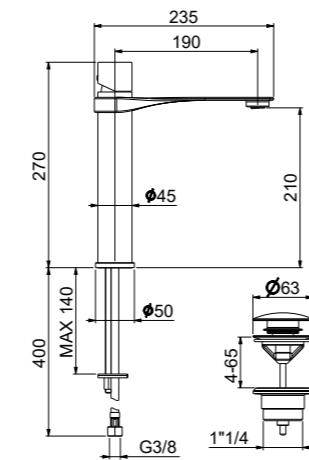
.741 Acciaio + bianco / Steel + white / Acier + blanc / Stahl + Weiss / Acero + blanco € 1.550,00



flex  
 AC0470000  Ø 25 mm  
AC0368000

 NB830402

## NB840101

 Kg 1,3  
Box pcs 8



Miscelatore monocomando per bidet con scarico up & down, con flex inox cm 50 att. 3/8" F.

Single lever bidet mixer with up & down pop-up waste, with 3/8" F flex. hoses cm 50.

Mitigeur de bidet avec vidage up & down, flexibles d'alimentation cm 50 3/8" F.

Einhebelmischer Bidetbatterie mit up & down Ablaufgarnitur 1" 1/4, mit flex. Anschlussschläuchen cm 50 3/8" F.

Monomando para bidé con desagüe up & down, tubo flexible inoxidable de 50 cm, empalme 3/8" F.

.015 Acciaio + cromo / Steel + chrome / Acier + chromée / Stahl + verchromt / Acero + cromado € 825,00

.441 Acciaio + nero / Steel + black / Acier + noir / Stahl + Schwarz / Acero + negro € 856,00

.741 Acciaio + bianco / Steel + white / Acier + blanc / Stahl + Weiss / Acero + blanco € 856,00

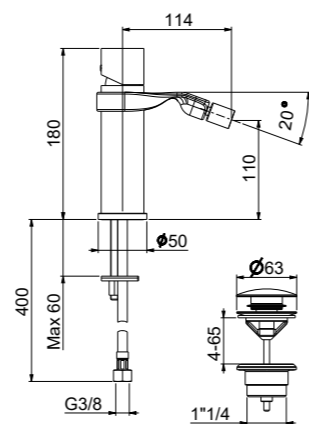

 AC0464015  Ø 25 mm  
AC0368000

 NB840102

## NB830606

 Kg 1,6  
Box pcs 8

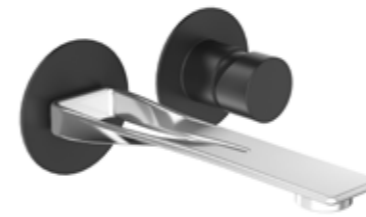

Miscelatore monocomando per lavabo incasso muro, con piastre separate, senza scarico e flessibili.

Concealed single lever washbasin mixer, with 2 cover plates, without pop-up waste and flex hoses.

Mitigeur de lavabo à encastrer, avec 2 rosaces, sans vidage et flexibles.

Einhebelmischer Unterputz-Waschtischbatterie, mit getrennten Platten, ohne Ablaufgarnitur und flex Anschlussschläuchen.





Monomando empotrable para lavabo de pared, con 2 placas, sin desagüe ni tubos flexibles.

.015 Acciaio + cromo / Steel + chrome / Acier + chromée / Stahl + verchromt / Acero + cromado € 1.750,00

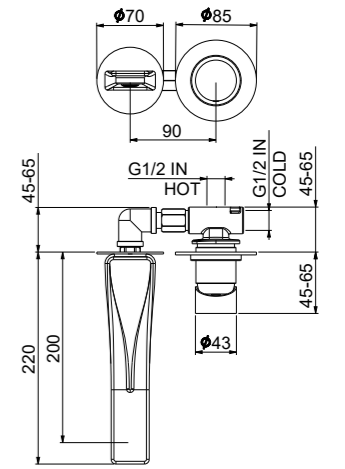
.441 Acciaio + nero / Steel + black / Acier + noir / Stahl + Schwarz / Acero + negro € 1.850,00

.741 Acciaio + bianco / Steel + white / Acier + blanc / Stahl + Weiss / Acero + blanco € 1.850,00



 AC1041015  AC1040015  
 AC0470000  Ø 35 mm  
AC0338000

## NB880101

 Kg 0,8  
Box pcs 24



Miscelatore monocomando per doccia incasso, con piastra, senza flessibile, doccetta e gancio.

Concealed single lever shower mixer with cover plate, without shower set.

Mitigeur de douche à encastrer avec rosace, sans garniture de douche.

Einhebelmischer Unterputz-Brausebatterie, mit Rosette ohne Brausegarnitur.

Monomando empotrable para ducha, con placa, sin tubo flexible, ducha ni gancho.

.015 Cromo / Chrome / Chromée / Verchromt / Cromado € 134,00

.560 Nero opaco / Matt black / Noir mat / Matt Schwarz / Negro mate € 185,00

.740 Bianco opaco / Matt white / Blanc mat / Matt Weiss / Blanco mate € 185,00

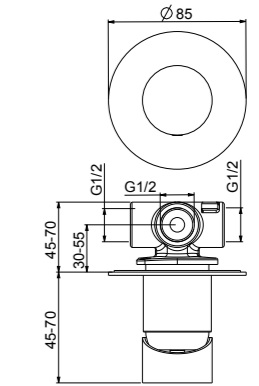

 AC1040015  Ø 35 mm  
AC0338000

## NB860101

 Kg 2,2  
Box pcs 12



Miscelatore monocomando per vasca incasso con deviatore, senza flessibile, doccetta e gancio di supporto.

Concealed single lever bath mixer with diverter, without shower set.

Mitigeur bain-douche à encastrer avec inverseur, sans garniture de douche.

Einhebelmischer Unterputz-Badebatterie mit Umstellung, ohne Brausegarnitur.

Monomando empotrable para bañera, con desviador; sin tubo flexible, rociador ni soporte.

.015 Cromo / Chrome / Chromée / Verchromt / Cromado € 280,00

.560 Nero opaco / Matt black / Noir mat / Matt Schwarz / Negro mate € 390,00

.740 Bianco opaco / Matt white / Blanc mat / Matt Weiss / Blanco mate € 390,00

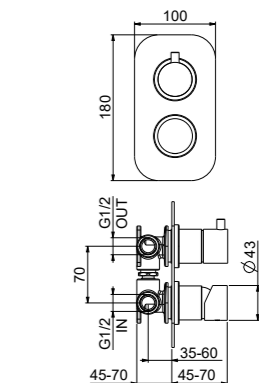

 Ø 35 mm  
AC0329000  AC1009015

## NB880601

Kg 2,2  
Box pcs 12



Miscelatore monocomando per doccia incasso con deviatore 3 vie.

Concealed single lever shower mixer, with 3-ways diverter.

Mitigeur de douche à encastrer avec inverseur 3 voies.

Einhebelmischer Unterputz-Brausebatterie mit 3 Wegeumsteller.

Monomando emprotable para ducha, con desviador 3 vías.

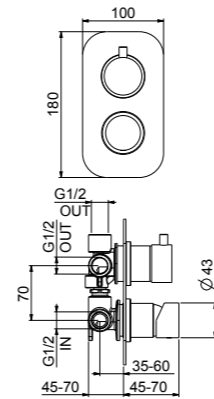

- .015 Cromo / Chrome / Chromée / Verchromt / Cromado € 430,00
- .560 Nero opaco / Matt black / Noir mat / Matt Schwarz / Negro mate € 599,00
- .740 Bianco opaco / Matt white / Blanc mat / Matt Weiss / Blanco mate € 599,00

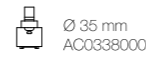

Ø 35 mm  
AC0338000



AC0335000

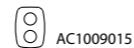

AC1009015

## NB850101

Kg 3,5  
Box pcs 5



Miscelatore monocomando per vasca esterno completo con flessibile da 150 cm, doccia anticalcare e supporto.

Single lever bath mixer with shower set complete of hose 150 cm, handshower and holder.

Mitigeur bain-douche complet de flexible 150 cm, douchette et support mural.

Einhebelmischer Badebatterie mit Brausegarnitur bestehend aus Brauseschlauch 150 cm, Handbrause und Wandhalterung.

Monomando externo para bañera completo, con tubo flexible de 150 cm, ducha a prueba de incrustaciones y soporte.

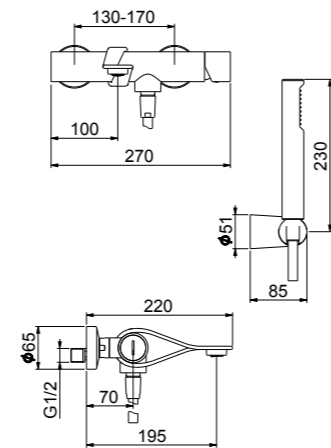

- .015 Acciaio + cromo / Steel + chrome / Acier + chromée / Stahl + verchromt / Acero + cromado € 1.600,00
- .441 Acciaio + nero / Steel + black / Acier + noir / Stahl + Schwarz / Acero + negro € 1.700,00
- .741 Acciaio + bianco / Steel + white / Acier + blanc / Stahl + Weiss / Acero + blanco € 1.700,00



Ø 35 mm  
AC0338000

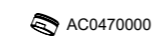

AC0470000

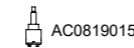

AC0819015

## NB870102

Kg 2,6  
Box pcs 12



Miscelatore monocomando per doccia esterno, senza flessibile, doccia e gancio di supporto.

Single lever shower mixer without shower set.

Mitigeur de douche sans garniture de douche.

Einhebelmischer Brausebatterie ohne Brausegarnitur.

Monomando externo para ducha, sin tubo flexible, ducha ni gancho de soporte.

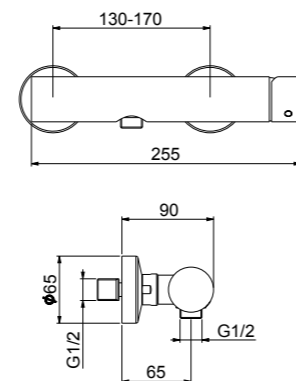

- .015 Cromo / Chrome / Chromée / Verchromt / Cromado € 190,00
- .560 Nero opaco / Matt black / Noir mat / Matt schwarz / Negro mate € 266,00
- .740 Bianco opaco / Mat white / Blanc mat / Matt Weiss / Blanco mate € 266,00



Ø 35 mm  
AC0338000

## AC1039

Kg 0,9  
Box pcs 12



Bocca d'erogazione senza deviatore per vasca incasso.

Spout for concealed bath mixer.

Bec pour mitigeur bain/douche encastré.

Gussauslauf für Unterputz-Badebatterie.

Boca de erogación sin desviador para bañera empotrable.

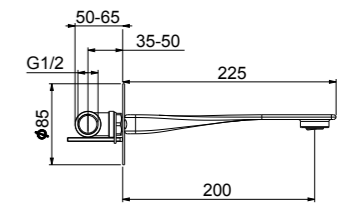

- .015 Acciaio + cromo / Steel + chrome / Acier + chromée / Stahl + verchromt / Acero + cromado € 1.210,00
- .441 Acciaio + nero / Steel + black / Acier + noir / Stahl + Schwarz / Acero + negro € 1.240,00
- .741 Acciaio + bianco / Steel + white / Acier + blanc / Stahl + Weiss / Acero + blanco € 1.240,00

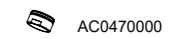

AC0470000

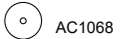

AC1068

ONE-A



### ON921201

Kg 2,3  
Box pcs 4



ON921202

Miscelatore monocomando per lavello, canna orientabile, flessibili cm 70 3/8" F.

Single lever sink mixer, swivel spout, with 3/8" F flex. hoses cm 70.

Mitigeur évier avec bec mobile et flexible d'alimentation cm 70 3/8" F.

EHM Stand-Spültischbatterie, mit schwenkbarem Auslauf und flex. Anschlussschläuchen cm 70 3/8" F.

Monomando para fregadero, caño orientable y tubos flexibles de 70 cm, 3/8" F.

.441 Acciaio + nero / Steel + black / Acier + noir / Stahl + Schwarz / Acero + negro € 2.350,00

.560 Nero opaco / Matt black / Noir mat / Matt Schwarz / Negro mate € 2.350,00

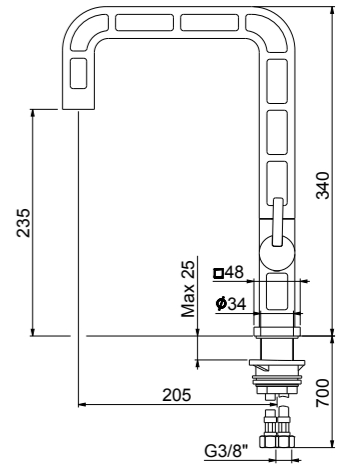

flex  
AC0760

AC0988000

Ø 25 mm  
AC1034000

Come una vera e propria scultura,

Il rubinetto One-A è così lavorato al suo interno da evocare il dinamismo e le geometrie di una texture 3D. Dirompente nel design, evoluto nella tecnologia, conferisce all'ambiente cucina un tocco di innovativa unicità.

Like a real sculpture,

the One-A faucet is so worked inside that it evokes the dynamism and geometries of a 3D texture. Amazing design, evolved in technology, gives the kitchen space a touch of innovative uniqueness.



Design:  
Massimiliano Settimelli

ONE SERIES

# O ESSENTIAL



## EN920301

 Kg 1,7  
 Box pcs 4



Miscelatore monocomando per lavello, canna orientabile, flessibili cm 70 3/8" F.

Single lever sink mixer, swivel spout, with 3/8" F flex. hoses cm 70.

Mitigeur évier avec bec mobile et flexible d'alimentation cm 70 3/8" F.

EHM Stand-Spültischbatterie, mit schwenkbarem Auslauf und flex. Anschlussschläuchen cm 70 3/8" F.

Monomando para fregadero, caño orientable y tubos flexibles de 70 cm, 3/8" F.

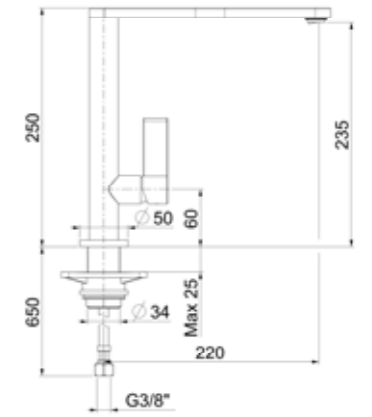

.441 Acciaio + nero / Steel + black / Acier + noir / Stahl + Schwarz / Acero + negro € 740,00

.560 Nero opaco / Matt black / Noir mat / Matt Schwarz / Negro mate € 740,00

 EN920302

 AC0470000

 Ø 25  
AC0926000

### Rigorous, minimale,

capace di re-inventare il rubinetto tradizionale. La particolare forma scultorea della bocca di erogazione si unisce alle sue linee pure ed essenziali, dando vita a un perfetto equilibrio tra semplicità e ricercatezza.

Contemporaneo e all'avanguardia, trasmette a tutto l'ambiente il suo carattere unico e riconoscibile.

### Rigorous, minimal,

able to re-invent the traditional tap. The particular sculptural form of the spout joins with its pure and essential lines, giving life to a perfect balance between simplicity and refinement.

Contemporary and avant-garde, it transmits its unique and iconic character to the whole space.

Design:  
Team Weibert



# ARIA



AI830401.015  
Miscelatore lavabo alto.  
One hole high basin mixer.

## FINITURE LEVE / LEVER FINISHINGS

 .081 TALCO	 .084 ARENARIA
 .082 POMICE	 .085 CACAO
 .083 BRINA	 .086 BASALTO

Design: Massimiliano Settimelli



AI860101.015  
Doccia incasso con deviatore.  
Concealed shower mixer with diverter.

AC0741.845  
Soffione multifunzione in acciaio.  
Stainless steel multifunction shower head.



Creata dal Designer Massimiliano Settimelli, la linea Aria custodisce un'energia dinamica capace d'infondersi in tutto l'ambiente del bagno. Dall'unione di design e natura nasce il lavabo a cascata, nel quale, racchiusa sotto la leva, si apre la scanalatura che rivela lo scorrere dell'acqua. La plasticità decisa del corpo centrale si piega verso la sottigliezza della bocca, in un'unica linea continua, che per dinamismo e fluidità, sottolinea il legame tra questa collezione e il suo elemento: l'aria.

Created by the designer Massimiliano Settimelli, Aria series holds a dynamic energy able to infuse itself in the entire bathroom space. The combination of design and nature generates a waterfall washbasin mixer. The groove under the lever disclosed the water flow. The firm plasticity of the central body bends towards the fineness of the spout in a sole and continuous line emphasizing, thanks to its dynamism and fluidity, the tie between this collection and its element: air.

Finiture / finishes / finitions / ausföhrungen / acabados

- |   |  |  |
|---|--|--|
| <p>.015<br/>Cromo<br/>Chrome<br/>Chromé<br/>Verchromt<br/>Cromado</p> | <p>.560<br/>Nero opaco<br/>Matt black<br/>Noir mat<br/>Matt Schwarz<br/>Negro mate</p> | <p>.844<br/>Bianco Lucido-Cromo<br/>Shiny White-Chrome<br/>Blanc Brillant-Chromé<br/>Glänzend Weiss-Chrom<br/>Blanco Brillante-Cromado</p> |
|---|--|--|



reddot design award  
winner

## AI830101

Kg 2,4  
Box pcs 8



Miscelatore monocomando per lavabo con scarico up & down, con flex inox cm 37 att. 3/8" F.

Single lever washbasin mixer with up & down pop-up waste, with 3/8" F flex. hoses cm 37.

Mitigeur de lavabo avec vidage up & down, flexibles d'alimentation cm 37 3/8" F.

Einhebelmischer Waschtischbatterie mit up & down Ablaufgarnitur, mit flex. Anschlussschläuchen cm 37 3/8" F.

Monomando para lavabo con valvula click-clack, tubo flexible inoxidable de 37 cm, empalme 3/8" F.

.015 Cromo / Chrome / Chromée / Verchromt / Cromado € 312,00

.844 Bianco lucido-Cromo / Shiny White-Chrome / Blanc Brillant-Chromé / Glänzend Weiss-Chrom / Blanco Brillante - Cromado € 341,00

.560 Nero opaco / Mat black / Noir mat / Matt Schwarz / Negro mate € 341,00

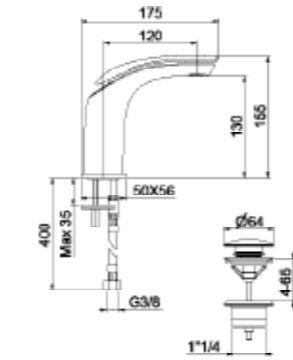

AC0752

AC0720000

Ø 25 mm  
AC1187

AI830102

## AI830401

Kg 2,8  
Box pcs 5



Miscelatore monocomando per lavabo alto con scarico up & down, flex inox cm 37 att. 3/8" F.

High single lever washbasin mixer with up & down pop-up waste, with 3/8" flex. hoses 37 cm.

Mitigeur de lavabo haut avec vidage up & down, flexibles d'alimentation cm 37 3/8" F.

Einhebelmischer Waschtischbatterie, mit hoher Ausführung, mit up & down Ablaufgarnitur, mit Flex. Anschlussschläuchen cm 37 3/8" F.

Monomando para lavabo alto con valvula click-clack, tubo flexible inoxidable de 37 cm, empalme 3/8" F.

.015 Cromo / Chrome / Chromée / Verchromt / Cromado € 368,00

.844 Bianco lucido-Cromo / Shiny White-Chrome / Blanc Brillant-Chromé / Glänzend Weiss-Chrom / Blanco Brillante - Cromado € 404,00

.560 Nero opaco / Mat black / Noir mat / Matt Schwarz / Negro mate € 404,00

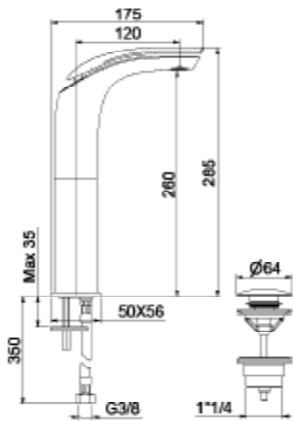

AC0752

AC0720000

Ø 25 mm  
AC1187

AI830402

## AI840101

Kg 2  
Box pcs 8



Miscelatore monocomando per bidet con scarico up & down, con flex inox cm 37 att. 3/8" F.

Single lever bidet mixer with up & down pop-up waste, with 3/8" F flex. hoses cm 37.

Mitigeur de bidet avec vidage up & down, flexibles d'alimentation cm 37 3/8" F.

Einhebelmischer Bidetbatterie mit up & down Ablaufgarnitur 1" 1/4, mit flex. Anschlussschläuchen cm 37 3/8" F.

Monomando para bidé con desagüe up & down, tubo flexible inoxidable de 37 cm, empalme 3/8" F.

.015 Cromo / Chrome / Chromée / Verchromt / Cromado € 312,00

.844 Bianco lucido-Cromo / Shiny White-Chrome / Blanc Brillant-Chromé / Glänzend Weiss-Chrom / Blanco Brillante - Cromado € 341,00

.560 Nero opaco / Mat black / Noir mat / Matt Schwarz / Negro mate € 341,00

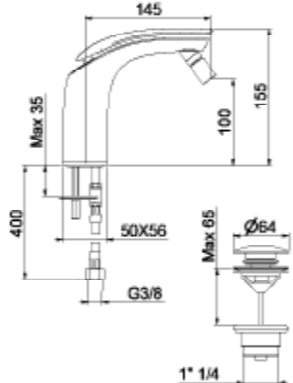

AC0752

AC0467015

Ø 25 mm  
AC1187

AI840102

## AI832001

Kg 1,9  
Box pcs 8



Miscelatore monocomando a cascata per lavabo con scarico up & down, con flex inox cm 37 att. 3/8" F.

Single lever washbasin mixer cascade with up & down pop-up waste, with 3/8" F flex. hoses cm 37.

Mitigeur de lavabo en cascade avec vidage up & down, flexibles d'alimentation cm 37 3/8" F.

Einhebelmischer Waschtischbatterie Kaskade mit up & down Ablaufgarnitur, mit und flex. Anschlussschläuchen cm 37 3/8" F.

Monomando para lavabo cascada con valvula click-clack, tubos flexibles acero inoxidable 37cm, 3/8" F.

.015 Cromo / Chrome / Chromée / Verchromt / Cromado € 357,00

.844 Bianco lucido-Cromo / Shiny White-Chrome / Blanc Brillant-Chromé / Glänzend Weiss-Chrom / Blanco Brillante - Cromado € 393,00

.560 Nero opaco / Matt black / Noir mat / Matt Schwarz / Negro mate € 393,00

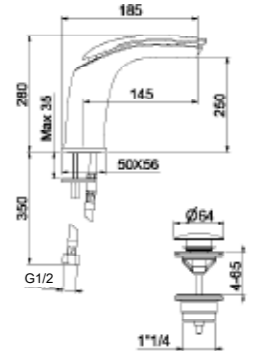

AC0752

AC0719000

Ø 25 mm  
AC1187

## AI832201

Kg 3  
Box pcs 8



Miscelatore monocomando a cascata per lavabo alto con scarico up & down, flex inox cm 37 att. 3/8" F.

High single lever washbasin mixer cascade with up & down pop-up waste, with 3/8" flex. hoses 37 cm.

Mitigeur de lavabo haut en cascade avec vidage up & down, flexibles d'alimentation cm 37 3/8" F.

Einhebelmischer Waschtischbatterie mit Kaskade, mit hoher Ausführung, mit up & down Ablaufgarnitur, mit und Flex. Anschlussschläuchen cm 37 3/8" F.

Monomando para lavabo alto cascada con valvula click-clack, tubos flexibles acero inoxidable 37cm, 3/8" F.

.015 Cromo / Chrome / Chromée / Verchromt / Cromado € 443,00

.844 Bianco lucido-Cromo / Shiny White-Chrome / Blanc Brillant-Chromé / Glänzend Weiss-Chrom / Blanco Brillante - Cromado € 487,00

.560 Nero opaco / Matt black / Noir mat / Matt Schwarz / Negro mate € 487,00

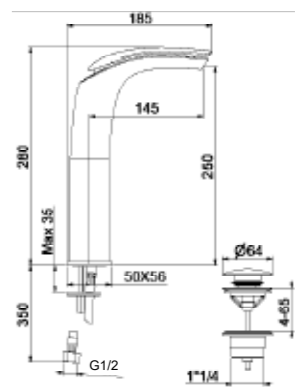

AC0752

AC0719000

Ø 25 mm  
AC1187

## AI830606

Kg 2,4  
Box pcs 8



Miscelatore monocomando per lavabo incasso muro, con piastre separate, senza scarico e flessibili.

Concealed single lever washbasin mixer, with 2 cover plates, without pop-up waste and flex hoses.

Mitigeur de lavabo à encastrer, avec 2 rosaces, sans vidage et flexibles.

Einhebelmischer Unterputz-Waschtischbatterie, mit getrennten Platten, ohne Ablaufgarnitur und flex Anschlussschläuchen.

Monomando emprotable para lavabo de pared, con 2 placas, sin desagüe ni tubos flexibles.

.015 Cromo / Chrome / Chromée / Verchromt / Cromado € 368,00

.844 Bianco lucido-Cromo / Shiny White-Chrome / Blanc Brillant-Chromé / Glänzend Weiss-Chrom / Blanco Brillante - Cromado € 403,00

.560 Nero opaco / Mat black / Noir mat / Matt Schwarz / Negro mate € 403,00

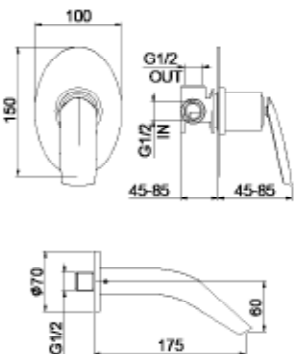

AC0342015

Ø 35 mm  
AC0687000

## AI832301

 Kg 5,5  
Box pcs 1

Miscelatore monocomando a cascata per lavabo a pavimento.

Single lever cascade floor mounted basin mixer.

Mitigeur lavabo en cascade au sol.

Einhebelmischer Stand-Waschtischbatterie mit Kaskade. Monomando de pie para lavabo de cascada.

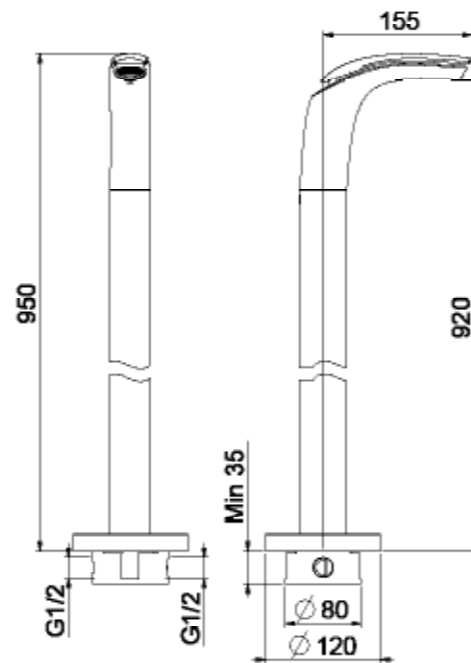
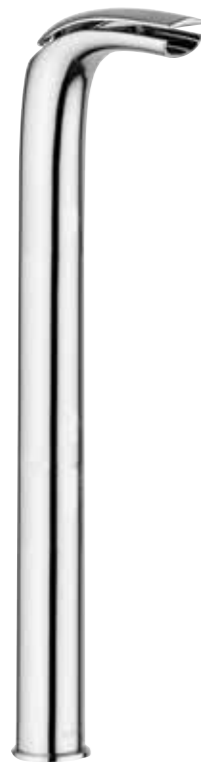

- .015 Cromo / Chrome / Chromée / Verchromt / Cromado € 984,00
- .844 Bianco lucido-Cromo / Shiny White-Chrome / Blanc Brillant-Chromé / Glänzend Weiss-Chrom / Blanco Brillante - Cromado € 1.071,00
- .560 Nero opaco / Matt black / Noir mat / Matt Schwarz / Negro mate € 1.071,00

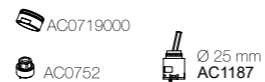

## AI880101

 Kg 2  
Box pcs 8

Miscelatore monocomando per doccia incasso, con piastra, senza flessibile, doccetta e gancio.

Concealed single lever shower mixer with cover plate, without shower set.

Mitigeur de douche à encastrer avec rosace, sans garniture de douche.

Einhebelmischer Unterputz-Brausebatterie, mit Rosette ohne Brausegarnitur.

Monomando empotrable para ducha, con placa, sin tubo flexible, ducha ni gancho.

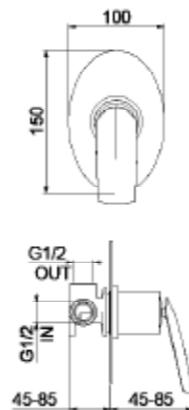

- .015 Cromo / Chrome / Chromée / Verchromt / Cromado € 184,00
- .844 Bianco lucido-Cromo / Shiny White-Chrome / Blanc Brillant-Chromé / Glänzend Weiss-Chrom / Blanco Brillante - Cromado € 203,00
- .560 Nero opaco / Matt black / Noir mat / Matt Schwarz / Negro mate € 203,00



## AI860101

 Kg 2,1  
Box pcs 12

Miscelatore monocomando per vasca incasso con deviatore, senza flessibile, doccetta e gancio di supporto.

Concealed single lever bath mixer with diverter, without shower set.

Mitigeur bain-douche à encastrer avec inverseur, sans garniture de douche.

Einhebelmischer Unterputz-Badebatterie mit Umstellung, ohne Brausegarnitur.

Monomando empotrable para bañera, con desviador; sin tubo flexible, rociador ni soporte.

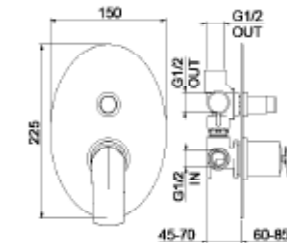

- .015 Cromo / Chrome / Chromée / Verchromt / Cromado € 302,00
- .844 Bianco lucido-Cromo / Shiny White-Chrome / Blanc Brillant-Chromé / Glänzend Weiss-Chrom / Blanco Brillante - Cromado € 333,00
- .560 Nero opaco / Matt black / Noir mat / Matt Schwarz / Negro mate € 333,00



## AC0680

 Kg 1,5  
Box pcs 12

Deviatore incasso completo, 3 vie.

Concealed 3 ways diverter.

Inverseur 3 voies encastré.

Unterputz 3-Weg Umsteller.

Desviador de 3 vías empotrable.

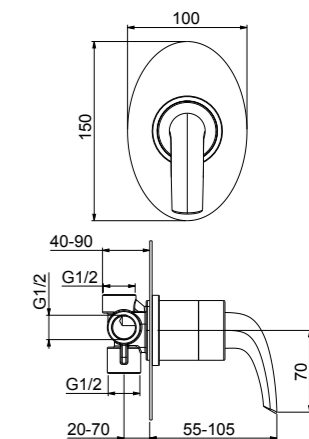

- .015 Cromo / Chrome / Chromée / Verchromt / Cromado € 194,00
- .844 Bianco lucido-Cromo / Shiny White-Chrome / Blanc Brillant-Chromé / Glänzend Weiss-Chrom / Blanco Brillante - Cromado € 214,00
- .560 Nero opaco / Matt black / Noir mat / Matt Schwarz / Negro mate € 214,00

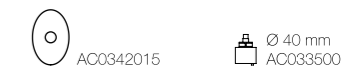

## AI850101

 Kg 3,9  
Box pcs 6

Miscelatore monocomando per vasca esterno completo con flessibile da 150 cm, doccetta anticalcare e supporto.

Single lever bath mixer with shower set complete of hose 150 cm, handshower and holder.

Mitigeur bain-douche complet de flexible 150 cm, douchette et support mural.

Einhebelmischer Badebatterie mit Brausegarnitur bestehend aus Brauseschlauch 150 cm, Handbrause und Wandhalterung.

Monomando externo para bañera completo, con tubo flexible de 150 cm, ducha antical y soporte.

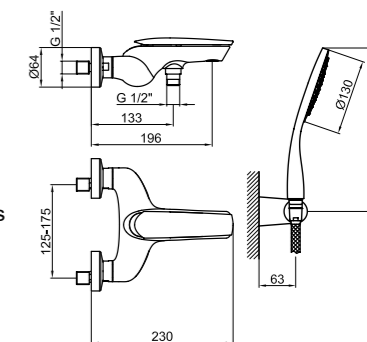

- .015 Cromo / Chrome / Chromée / Verchromt / Cromado € 400,00
- .844 Bianco lucido-Cromo / Shiny White-Chrome / Blanc Brillant-Chromé / Glänzend Weiss-Chrom / Blanco Brillante - Cromado € 440,00
- .560 Nero opaco / Matt black / Noir mat / Matt Schwarz / Negro mate € 440,00



## AI870102

Kg 2,6  
Box pcs 6



Miscelatore monocomando per doccia esterno, senza flessibile, doccetta e gancio di supporto.

Single lever shower mixer without shower set.

Mitigeur de douche sans garniture de douche.

Einhebelmischer Brausebatterie ohne Brausegarnitur.

Monomando externo para ducha, sin tubo flexible, ducha ni gancho de soporte.

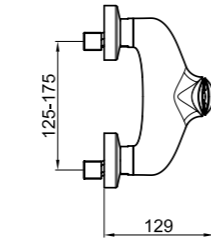
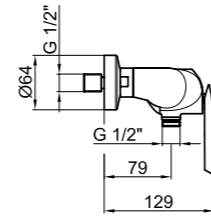

Ø 35 mm  
AC0686000

.015 Cromo / Chrome / Chromée / Verchromt / Cromado € 249,00

.844 Bianco lucido-Cromo / Shiny White-Chrome / Blanc Brillant-Chromé / Glänzend Weiss-Chrom / Blanco Brillante - Cromado € 274,00

.560 Nero opaco / Matt black / Noir mat / Matt Schwarz / Negro mate € 274,00

153 + € 15,00

## AC0869

Kg 0,7  
Box pcs 12



Bocca d'erogazione senza deviatore per vasca incasso; attacco da 1/2".

Spout for concealed bath mixer, 1/2" connection.

Bec pour mitigeur bain/douche encastré, attache 1/2".

Gussauslauf für Unterputz-Badebatterie, 1/2" Anschluss.

Boca de erogación sin desviador para bañera empotrable; conexión 1/2".

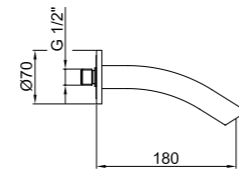

.015 Cromo / Chrome / Chromée / Verchromt / Cromado € 165,00

.844 Bianco lucido-Cromo / Shiny White-Chrome / Blanc Brillant-Chromé / Glänzend Weiss-Chrom / Blanco Brillante - Cromado € 173,00

.560 Nero opaco / Matt black / Noir mat / Matt Schwarz / Negro mate € 173,00

## AC0765

Leva lavabo-bidet aria.

Aria washbasin-bidet handle.

Poignée lavabo et bidet Aria.

Aria Waschtisch-und Bidetmischer Hebel.

Maneta lavabo-bidé Aria.



.015 Cromo / Chrome / Chromée / Verchromt / Cromado € 15,80

Talco - Pomice - Brina - Arenaria - Cacao - Basalto € 24,00

## AC0766

Leva vasca esterno aria.

Aria external bath mixer handle.

Poignée mitigeur de bain-douche Aria.

Aria Bademischer Hebel.

Maneta bañera exterior.

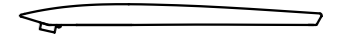

.015 Cromo / Chrome / Chromée / Verchromt / Cromado € 16,80

Talco - Pomice - Brina - Arenaria - Cacao - Basalto € 24,00

## AC0767

Leva doccia esterno - doccia e vasca incasso aria.

Aria external shower mixer and concealed bath mixer handle.

Poignée mitigeur de douche et de bain-douche encastré Aria.

Aria Brausemischer und Unterputz-Badebatterie Hebel.

Maneta para ducha exterior, ducha y bañera a empotrar Aria.

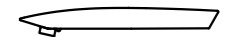

.015 Cromo / Chrome / Chromée / Verchromt / Cromado € 15,80

Talco - Pomice - Brina - Arenaria - Cacao - Basalto € 24,00

## AI500501

## AI500601

Kg 1,2  
Box pcs 4

Kg 1,4  
Box pcs 4

Porta asciugamano in ottone.

Brass towel holder.

Porte serviette en laiton.

Handtuchhalter aus Messing.

Toallero de latón.

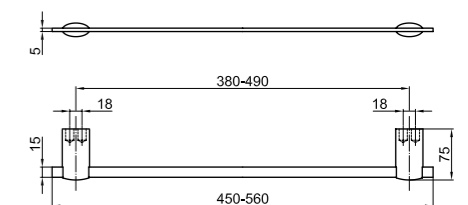

AI500501 cm 45 .015 Cromo / Chrome / Chromée / Verchromt / Cromado € 172,00

AI500601 cm 56 .015 Cromo / Chrome / Chromée / Verchromt / Cromado € 189,00

### AI501201

 Kg 0,2  
Box pcs 6



Anello porta salviette.  
Ring shaped towel holder.  
Porte serviettes à anneau.  
Handtuchring.  
Toallero anilla.

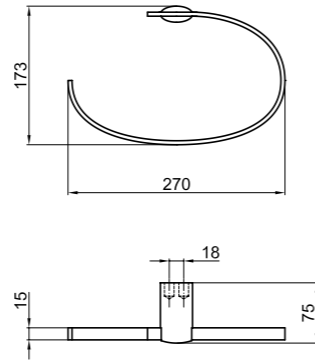

.015 Cromo / Chrome / Chromée / Verchromt / Cromado € 125,00

### AI500401

 Kg 0,2  
Box pcs 12



Appendino in ottone.  
Hook in brass.  
Peignoir en laiton.  
Haken aus Messing.  
Percha en latón.

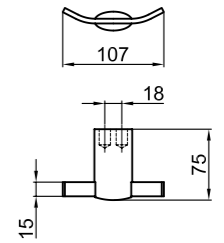

.015 Cromo / Chrome / Chromée / Verchromt / Cromado € 84,00

### AI500101

 Kg 1,6  
Box pcs 10



Porta sapone a parete in ceramica.  
Wall mounted ceramic soap dish.  
Porte savon mural en céramique.  
Seifenschale aus Keramik.  
Jabonera de pared de ceramica.

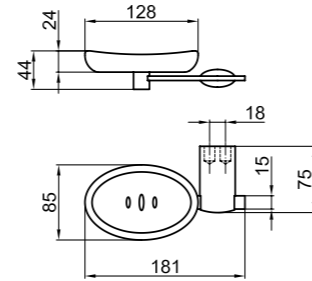

.015 Cromo / Chrome / Chromée / Verchromt / Cromado € 120,00

### AI500801

 Kg 1,6  
Box pcs 2



Porta rotolo.  
Toilet roll holder.  
Support en laiton pour papier rouleaux.  
Toilettenpapierhalter aus Messing.  
Portarrollo de latón.

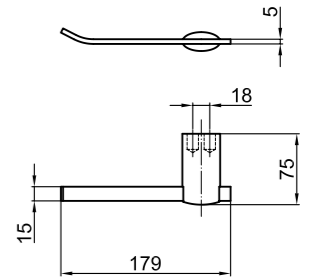

.015 Cromo / Chrome / Chromée / Verchromt / Cromado € 89,00

### AI500201

 Kg 1  
Box pcs 10



Porta dosatore sapone liquido a parete in ceramica con pompetta in metallo.  
Wall mounted ceramic liquid soap dispenser.  
Distributeur de savon liquide mural en céramique.  
Seifenspender aus Keramik.  
Dosificador de pared cerámico.

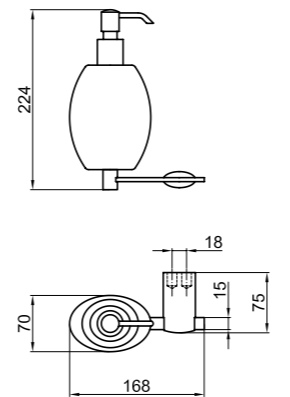

.015 Cromo / Chrome / Chromée / Verchromt / Cromado € 208,00

### AI850101

 Kg 0,2  
Box pcs 4



Porta scopino ovale in ottone a pavimento.  
Free standing brass oval-shaped toilet brush holder.  
Porte balai WC au sol ovale, en laiton.  
Oval WC-Bürstenständer aus Messing.  
Escobillero oval de suelo en latón.

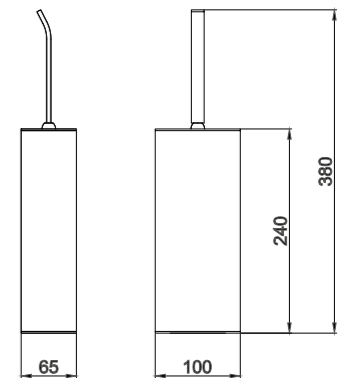

.015 Cromo / Chrome / Chromée / Verchromt / Cromado € 217,00

### AI501101

 Kg 1,9  
Box pcs 10



Porta sapone e porta bicchiere in ceramica a parete.  
Wall mounted ceramic soap dish and tumbler.  
Porte savon et porte verre en céramique mural.  
Seifenschale mit mudbecher aus Keramik.  
Jabonera y portavaso a pared de ceramica.

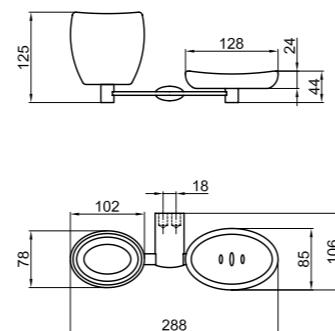

.015 Cromo / Chrome / Chromée / Verchromt / Cromado € 161,00

# CORAL

Design: BMB Progetti



Finiture / finishes / finitions / ausföhrungen / acabados

.015  
Cromo  
Chrome  
Chromé  
Verchromt  
Cromado

.560  
Nero opaco  
Matt black  
Noir mat  
Matt Schwarz  
Negro mate

.564  
Nero opaco-Cromo  
Matt black-Chrome  
Noir mat-Chromé  
Matt Schwarz-Verchromt  
Negro mate-Cromado



FINITURE LEVE / LEVER FINISHINGS



CO830401.015  
Miscelatore lavabo alto.  
One hole high basin mixer.



**Ispirata alla natura, ai suoi tesori sommersi.**

Le forme semplici ed essenziali della collezione Coral si arricchiscono di un dettaglio unico.

La sua leva è scolpita e plasmata per richiamare le forme organiche sottomarine e il colore vibrante dei coralli naturali. L'ambiente bagno diventa subito altrettanto ricercato e prezioso.

**Inspired by nature and its underwater treasures.**

The simple and essential shapes of Coral collection are enriched with a unique detail.

Its lever is sculpted and shaped to recall the underwater organic forms and the vibrant color of natural corals. Your bathroom immediately becomes just as refined and precious.



CO860512.015  
Miscelatore vasca incasso.  
Concealed bath mixer.

AC1005.015  
Bocca a muro.  
Wall spout.



## CO830101

Kg 1,4  
Box pcs 12



Miscelatore monocomando per lavabo con scarico up & down con flex inox cm 50 att. 3/8" F.

Single lever washbasin mixer with 1"1/4 pop-up waste, with 3/8" F flex. hoses cm 50.

Mitigeur de lavabo avec vidage automatique 1"1/4 et flexibles d'alimentation cm 50 3/8" F.

Einhebelmischer Waschtischbatterie mit Ablaufgarnitur 1"1/4 und flex. Anschlussschläuchen cm 50 3/8" F.

Monomando para lavabo con desagüe 1"1/4, tubo flexible inoxidable de 50 cm, empalme 3/8" F.

- |      |  |          |
|------|--|----------|
| .015 | Cromo / Chrome / Chromée / Verchromt / Cromado   | € 244,00 |
| .560 | Nero opaco / Matt black / Noir mat / Matt Schwarz / Negro mate                                       | € 340,00 |
| .564 | Nero opaco-Cromo / Matt black-Chrome / Noir mat-Chromé / Matt Schwarz-Verchromt / Negro mate-Cromado | € 340,00 |

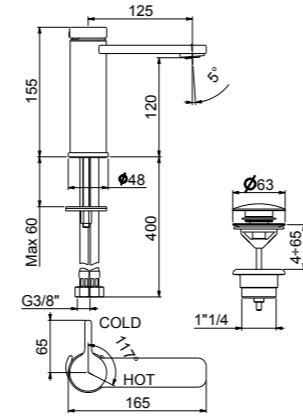

CO830102

## CO830401

Kg 2  
Box pcs 4



Miscelatore monocomando per lavabo alto con scarico up & down, flex inox cm 70 att. 3/8" F.

High single lever washbasin mixer with up & down pop-up waste, with 3/8" flex. hoses 70 cm.

Mitigeur de lavabo haut avec vidage up & down, flexibles d'alimentation cm 70 3/8" F.

Einhebelmischer Waschtischbatterie, mit hoher Ausführung, mit up & down Ablaufgarnitur, mit Flex. Anschlussschläuchen cm 70 3/8" F.

Monomando para lavabo alto con valvula click-clack, tubo flexible inoxidable de 70 cm, empalme 3/8" F.

- |      |  |          |
|------|--|----------|
| .015 | Cromo / Chrome / Chromée / Verchromt / Cromado   | € 348,00 |
| .560 | Nero opaco / Matt black / Noir mat / Matt Schwarz / Negro mate                                       | € 485,00 |
| .564 | Nero opaco-Cromo / Matt black-Chrome / Noir mat-Chromé / Matt Schwarz-Verchromt / Negro mate-Cromado | € 485,00 |

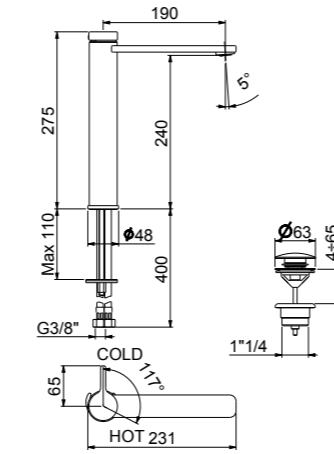

CO830402

## CO840101

Kg 1,4  
Box pcs 12



Miscelatore monocomando per bidet con scarico up & down, con flex inox cm 50 att. 3/8" F.

Single lever bidet mixer with up & down pop-up waste, with 3/8" F flex. hoses cm 50.

Mitigeur de bidet avec vidage up & down, flexibles d'alimentation cm 50 3/8" F.

Einhebelmischer Bidetbatterie mit up & down Ablaufgarnitur 1" 1/4, mit flex. Anschlussschläuchen cm 50 3/8" F.

Monomando para bidé con desagüe up & down, tubo flexible inoxidable de 50 cm, empalme 3/8" F.

- |      |  |          |
|------|--|----------|
| .015 | Cromo / Chrome / Chromée / Verchromt / Cromado   | € 244,00 |
| .560 | Nero opaco / Matt black / Noir mat / Matt Schwarz / Negro mate                                       | € 340,00 |
| .564 | Nero opaco-Cromo / Matt black-Chrome / Noir mat-Chromé / Matt Schwarz-Verchromt / Negro mate-Cromado | € 340,00 |

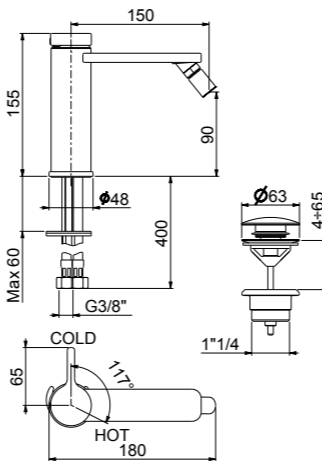

CO840102

## CO830606

Kg 1,6  
Box pcs 4



Miscelatore monocomando per lavabo incasso muro, con piastre separate, senza scarico e flessibili.

Concealed single lever washbasin mixer, with 2 cover plates, without pop-up waste and flex hoses.

Mitigeur de lavabo à encastrer, avec 2 rosaces, sans vidage et flexibles.

Einhebelmischer Unterputz-Waschtischbatterie, mit getrennten Platten, ohne Ablaufgarnitur und flex Anschlussschläuchen.

Monomando empotrable para lavabo de pared, con 2 placas, sin desagüe ni tubos flexibles.

- |      |  |          |
|------|--|----------|
| .015 | Cromo / Chrome / Chromée / Verchromt / Cromado   | € 332,00 |
| .560 | Nero opaco / Matt black / Noir mat / Matt Schwarz / Negro mate                                       | € 464,00 |
| .564 | Nero opaco-Cromo / Matt black-Chrome / Noir mat-Chromé / Matt Schwarz-Verchromt / Negro mate-Cromado | € 464,00 |

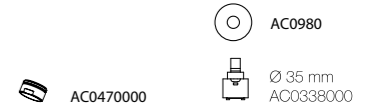
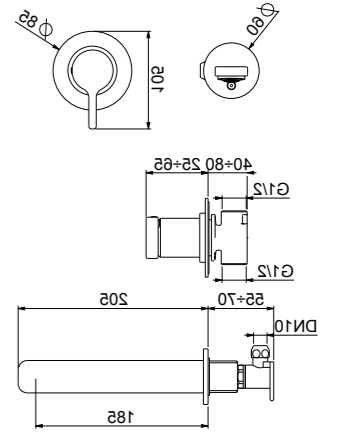

## CO880101

Kg 0,8  
Box pcs 12



Miscelatore monocomando per doccia incasso, con piastra, senza flessibile, doccetta e gancio.

Concealed single lever shower mixer with cover plate, without shower set.

Mitigeur de douche à encastrer avec rosace, sans garniture de douche.

Einhebelmischer Unterputz-Brausebatterie, mit Rosette ohne Brausegarnitur.

Monomando empotrable para ducha, con placa, sin tubo flexible, ducha ni gancho.

- |      |  |          |
|------|--|----------|
| .015 | Cromo / Chrome / Chromée / Verchromt / Cromado   | € 134,00 |
| .560 | Nero opaco / Matt black / Noir mat / Matt Schwarz / Negro mate                                       | € 185,00 |
| .564 | Nero opaco-Cromo / Matt black-Chrome / Noir mat-Chromé / Matt Schwarz-Verchromt / Negro mate-Cromado | € 185,00 |

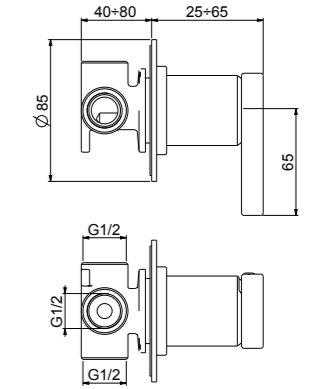

## CO860101

Kg 3  
Box pcs 12



Miscelatore monocomando per vasca incasso con deviatore, senza flessibile, doccetta e gancio di supporto.

Concealed single lever bath mixer with diverter, without shower set.

Mitigeur bain-douche à encastrer avec inverseur, sans garniture de douche.

Einhebelmischer Unterputz-Badebatterie mit Umstellung, ohne Brausegarnitur.

Monomando empotrable para bañera, con desviador; sin tubo flexible, rociador ni soporte.

- |      |  |          |
|------|--|----------|
| .015 | Cromo / Chrome / Chromée / Verchromt / Cromado   | € 280,00 |
| .560 | Nero opaco / Matt black / Noir mat / Matt Schwarz / Negro mate                                       | € 390,00 |
| .564 | Nero opaco-Cromo / Matt black-Chrome / Noir mat-Chromé / Matt Schwarz-Verchromt / Negro mate-Cromado | € 390,00 |

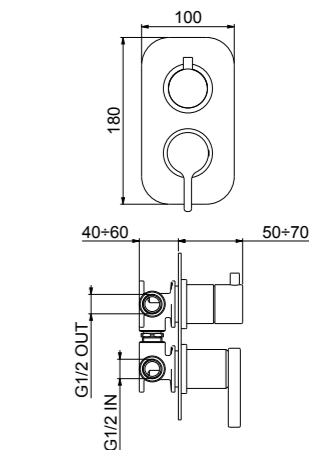

## CO880601

Kg 3  
Box pcs 12



Miscelatore monocomando per doccia incasso, con deviatore 3 vie.

Concealed single lever shower mixer, with 3-ways diverter.

Mitigeur de douche encastré avec inverseur 3 voies.

Einhebelmischer Unterputz-Brausebatterie mit 3 Wegeumsteller.

Monomando empotrable para ducha, con desviador 3 vías.

- .015 Cromo / Chrome / Chromée / Verchromt / Cromado € 430,00
- .560 Nero opaco / Matt black / Noir mat / Matt Schwarz / Negro mate € 599,00
- .564 Nero opaco-Cromo / Matt black-Chrome / Noir mat-Chromé / Matt Schwarz-Verchromt / Negro mate-Cromado € 599,00

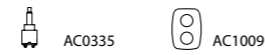
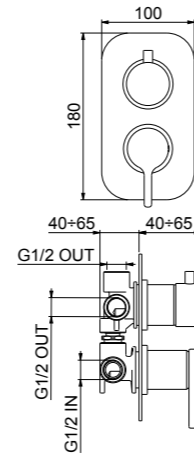

## AC1021

Leva Coral.

Coral handle.

Poignée Coral.

Coral Hebel.

Maneta Coral.



.081 Talco € 24,00



.083 Brina € 24,00



.084 Arenaria € 24,00



.085 Cacao € 24,00



.086 Basalto € 24,00

## CO860512

Kg 3  
Box pcs 12



Miscelatore monocomando per vasca incasso, con deviatore, piastra orizzontale, con flessibile, doccetta e gancio di supporto.

Concealed single lever bath mixer with diverter, horizontal cover plate, with shower set.

Mitigeur bain-douche à encastrer avec inverseur, rosace horizontal, avec garniture de douche.

Einhebelmischer Unterputz-Badebatterie mit Umstellung, waagerechte Rosette, mit Brausegarnitur.

Monomando empotrable para bañera, con desviador, placa horizontal, con flexible, ducha y soporte.

- .015 Cromo / Chrome / Chromée / Verchromt / Cromado € 374,00
- .560 Nero opaco / Matt black / Noir mat / Matt Schwarz / Negro mate € 524,00
- .564 Nero opaco-Cromo / Matt black-Chrome / Noir mat-Chromé / Matt Schwarz-Verchromt / Negro mate-Cromado € 524,00

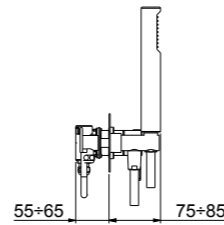
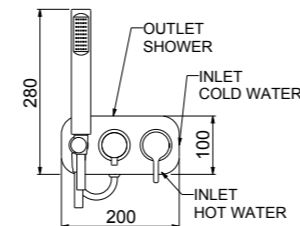

## AC1005

Kg 0,9  
Box pcs 12



Bocca d'erogazione senza deviatore per vasca incasso.

Spout for concealed bath mixer.

Bec pour mitigeur bain/douche encastré.

Gussauslauf für Unterputz-Badebatterie.

Boca de erogación sin desviador para bañera empotrable.

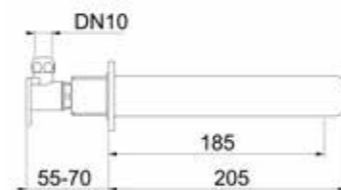

- .015 Cromo / Chrome / Chromée / Verchromt / Cromado € 198,00
- .560 Nero opaco / Matt black / Noir mat / Matt Schwarz / Negro mate € 275,00
- .564 Nero opaco-Cromo / Matt black-Chrome / Noir mat-Chromé / Matt Schwarz-Verchromt / Negro mate-Cromado € 275,00



ACCESSORI  
*bagno*



APPENDINO / HOOK  
ART. OA500401.320



PORTA DOSATORE SAPONE LIQUIDO /  
WALL MOUNTED LIQUID SOAP DISPENSER  
ART. OA500201.320



PORTA ASCIUGAMANO /  
TOWEL HOLDER  
ART. OA500501.320



PORTA BICCHIERE A PARETE /  
WALL MOUNTED TUMBLER  
ART. OA500301.320



OPERA

MET.

*Rosa antico*



LAVABO / BASIN MIXER  
ART. OA830401.320  
ROSA ANTICO





LAVABO / BASIN MIXER  
ART. OA830101.320  
ROSA ANTICO



LAVABO / BASIN MIXER  
ART. OA830101.325  
CHAMPAGNE

LAVABO ALTO / HIGH BASIN MIXER  
ART. OA830401.325  
CHAMPAGNE

# OPERA

Design: Massimiliano Settimelli



Superfici d'oro e un corpo che rimanda alle linee di eleganti strumenti d'orchestra. Nata dal Designer Massimiliano Settimelli, la collezione Opera custodisce la maestria e la bellezza dell'arte italiana: gusto raffinato e forme antiche si fondono, evocando il fascino di un autentico capolavoro.

Gold surfaces and a body recalls the lines of elegant orchestra instruments. Created by Massimiliano Settimelli, the Opera collection holds the artistry and the beauty of Italian art: refined taste and ancient forms blend, recalling the charm of a true masterpiece.

OA830101.980  
Miscelatore lavabo.  
One hole basin mixer.

## Finiture / finishes / finitions / ausföhrungen / acabados

.015	.010	.980	.560	.065	Collezione
Cromo	Oro	Oro rosa	Nero opaco	Bronzato	Primavera
Chrome	Gold	Rose gold	Matt black	Bronze	
Chromé	Doré	Or rose	Noir mat	Bronze	
Verchromt	Gold	Rose gold	Matt Schwarz	Bronze	
Cromado	Oro	Oro rosa	Negro mate	Bronce	



## OA830101

Kg 2,3  
Box pcs 8



OA830102

Miscelatore monocomando per lavabo con scarico up & down con flex inox cm 50 att. 3/8" F.

Single lever washbasin mixer with 1"1/4 pop-up waste, with 3/8" F flex. hoses cm 50.

Mitigreur de lavabo avec vidage automatique 1"1/4 et flexibles d'alimentation cm 50 3/8" F.

Einhebelmischer Waschtischbatterie mit Ablaufgarnitur 1"1/4 und flex. Anschlussschläuchen cm 50 3/8" F.

Monomando para lavabo con desagüe 1"1/4, tubo flexible inoxidable de 50 cm, empalme 3/8" F.

.015	Cromo / Chrome / Chromée / Verchromt / Cromado	€ 312,00
.560	Nero opaco / Matt black / Noir mat / Matt Schwarz / Negro mate	€ 343,00
.065	Bronzo / Bronze / Bronze / Bronze / Bronze	€ 390,00
.010	Oro / Gold / Doré / Gold / Oro	€ 390,00
.980	Oro rosa / Rose gold / Or rose / Rose gold / Oro rosa	€ 412,00
	Collezione Primavera	€ 390,00

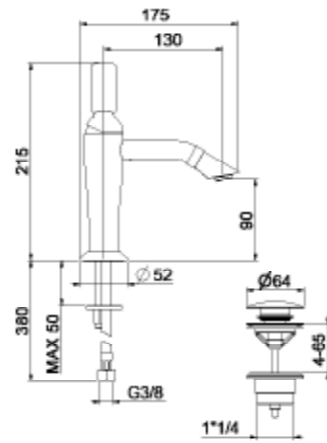

AC0470000 Ø 35 mm  
AC0977000

## OA830401

Kg 3,5  
Box pcs 4



OA830402

Miscelatore monocomando per lavabo alto con scarico up & down, flex inox cm 70 att. 3/8" F.

High single lever washbasin mixer with up & down pop-up waste, with 3/8" flex. hoses 70 cm.

Mitigreur de lavabo haut avec vidage up & down, flexibles d'alimentation cm 70 3/8" F.

Einhebelmischer Waschtischbatterie, mit hoher Ausführung, mit up & down Ablaufgarnitur, mit Flex. Anschlussschläuchen cm 70 3/8" F.

Monomando para lavabo alto con valvula click-clack, tubo flexible inoxidable de 70 cm, empalme 3/8" F.

.015	Cromo / Chrome / Chromée / Verchromt / Cromado	€ 368,00
.560	Nero opaco / Matt black / Noir mat / Matt Schwarz / Negro mate	€ 415,00
.065	Bronzo / Bronze / Bronze / Bronze / Bronze	€ 460,00
.010	Oro / Gold / Doré / Gold / Oro	€ 460,00
.980	Oro rosa / Rose gold / Or rose / Rose gold / Oro rosa	€ 486,00
	Collezione Primavera	€ 460,00

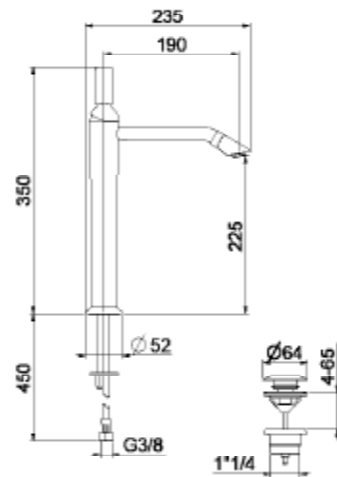

AC0470000 Ø 35 mm  
AC0977000

## OA840101

Kg 2  
Box pcs 8



OA840102

Miscelatore monocomando per bidet con scarico up & down, con flex inox cm 50 att. 3/8" F.

Single lever bidet mixer with up & down pop-up waste, with 3/8" F flex. hoses cm 50.

Mitigreur de bidet avec vidage up & down, flexibles d'alimentation cm 50 3/8" F.

Einhebelmischer Bidetbatterie mit up & down Ablaufgarnitur 1" 1/4, mit flex. Anschlussschläuchen cm 50 3/8" F.

Monomando para bidé con desagüe up & down, tubo flexible inoxidable de 50 cm, empalme 3/8" F.

.015	Cromo / Chrome / Chromée / Verchromt / Cromado	€ 312,00
.560	Nero opaco / Matt black / Noir mat / Matt Schwarz / Negro mate	€ 343,00
.065	Bronzo / Bronze / Bronze / Bronze / Bronze	€ 390,00
.010	Oro / Gold / Doré / Gold / Oro	€ 390,00
.980	Oro rosa / Rose gold / Or rose / Rose gold / Oro rosa	€ 412,00
	Collezione Primavera	€ 390,00

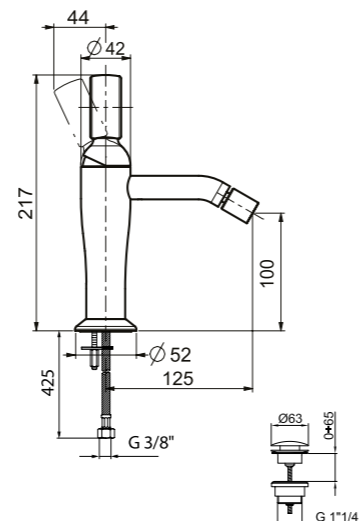

AC0464000 Ø 35 mm  
AC0977000

## OA830606

Kg 4  
Box pcs 4



PER FINITURE CONSULTARE  
SEZIONE EASY BATHROOM A PAG. 260

FOR ALL AVAILABLE FINISHINGS  
PLEASE GO TO EASY BATHROOM P. 260

Miscelatore monocomando per lavabo incasso muro, con piastre separate, senza scarico e flessibili.

Concealed single lever washbasin mixer, with 2 cover plates, without pop-up waste and flex hoses.

Mitigreur de lavabo à encastrer, avec 2 rosaces, sans vidage et flexibles.

Einhebelmischer Unterputz-Waschtischbatterie, mit getrennten Platten, ohne Ablaufgarnitur und flex Anschlussschläuchen.

Monomando empotrable para lavabo de pared, con 2 placas, sin desagüe ni tubos flexibles.

.015	Cromo / Chrome / Chromée / Verchromt / Cromado	€ 342,00
------	--	----------

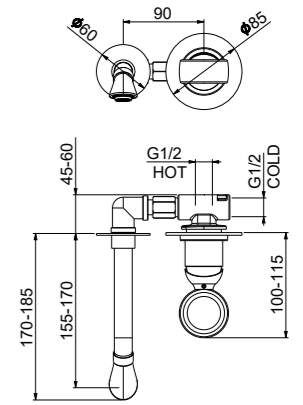

AC0979015 AC0470000  
AC0980015 Ø 35 mm  
AC0338000

## OA750502

Kg 3  
Box pcs 4



Batteria per lavabo a tre fori completa con scarico up & down.

3-holes washbasin mixer with up & down pop-up waste.

Mélangeur de lavabo 3-trous bec fixe avec vidage up & down.

3-Loch-Waschtischbatterie mit up & down Ablaufgarnitur.

Grifo bimando para lavabo de repisa, 3 agujeros, desagüe up & down.

.015	Cromo / Chrome / Chromée / Verchromt / Cromado	€ 368,00
.560	Nero opaco / Matt black / Noir mat / Matt Schwarz / Negro mate	€ 405,00
.065	Bronzo / Bronze / Bronze / Bronze / Bronze	€ 460,00
.010	Oro / Gold / Doré / Gold / Oro	€ 460,00
.980	Oro rosa / Rose gold / Or rose / Rose gold / Oro rosa	€ 508,00
	Collezione Primavera	€ 466,00

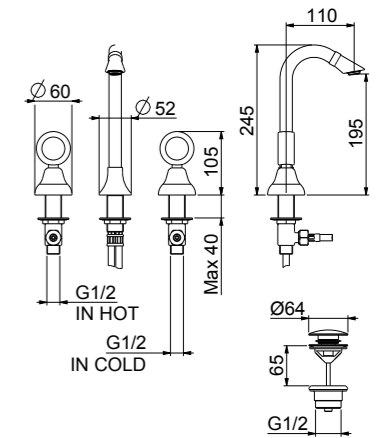

AC0470000 AC0331  
AC0332

## OA880101

Kg 1,6  
Box pcs 12



PER FINITURE CONSULTARE  
SEZIONE EASY BATHROOM A PAG. 260

FOR ALL AVAILABLE FINISHINGS  
PLEASE GO TO EASY BATHROOM P. 260

Miscelatore monocomando per doccia incasso, con piastra, senza flessibile, doccia e gancio.

Concealed single lever shower mixer with cover plate, without shower set.

Mitigreur de douche à encastrer avec rosace, sans garniture de douche.

Einhebelmischer Unterputz-Brausebatterie, mit Rosette ohne Brausegarnitur.

Monomando empotrable para ducha, con placa, sin tubo flexible, ducha ni gancho.

.015	Cromo / Chrome / Chromée / Verchromt / Cromado	€ 184,00
------	--	----------

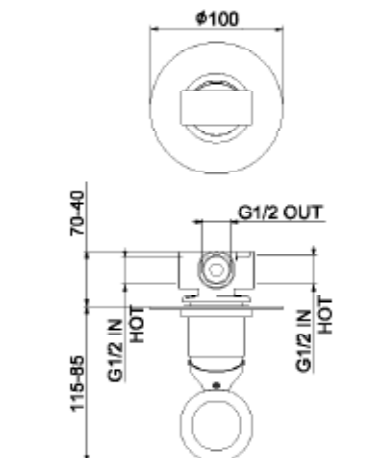

AC1118 Ø 35 mm  
AC0338000

## OA860101

Kg 2,5  
Box pcs 12



Miscelatore monocomando per vasca incasso con deviatore, senza flessibile, doccia e gancio di supporto.

Concealed single lever bath mixer with diverter, without shower set.

Mitigeur bain-douche à encastrer avec inverseur, sans garniture de douche.

Einhebelmischer Unterputz-Badebatterie mit Umstellung, ohne Brausegarnitur.

Monomando empotrable para bañera, con desviador; sin tubo flexible, rociador ni soporte.

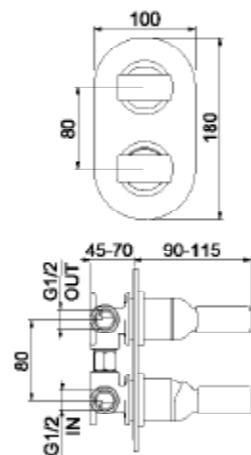

PER FINITURE CONSULTARE  
SEZIONE EASY BATHROOM A PAG. 260

FOR ALL AVAILABLE FINISHINGS  
PLEASE GO TO EASY BATHROOM P. 260

.015 Cromo / Chrome / Chromée / Verchromt / Cromado € 300,00

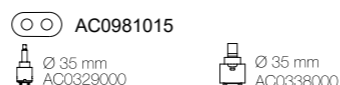

## OA860312

Kg 4  
Box pcs 4



Vasca incasso con bocca, deviatore, flessibile e doccia monojetto.

Concealed bath mixer with spout, diverter, flex. hose and monospray handshower.

Mélangeur bain-douche à encastrer avec inverseur, flexible et douchette mono-jet.

Unterputz-Badebatterie mit Umstellung, Metallbrauseschlauch und Mono-Wasserstrahl Handbrause.

Bateria bañera empotrable con desviador, flexible y ducha.

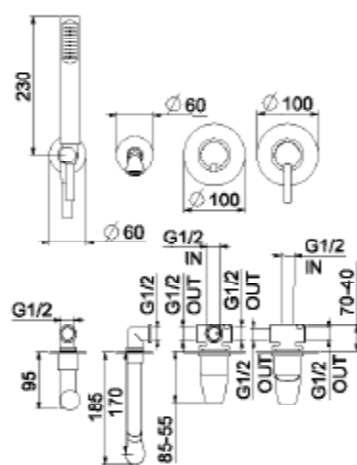

.015 Cromo / Chrome / Chromée / Verchromt / Cromado € 496,00

.560 Nero opaco / Matt black / Noir mat / Matt Schwarz / Negro mate € 545,00

.065 Bronzo / Bronze / Bronze / Bronze / Bronze € 620,00

.010 Oro / Gold / Doré / Gold / Oro € 620,00

.980 Oro rosa / Rose gold / Or rose / Rose gold / Oro rosa € 655,00

Collezione Primavera 2023 € 620,00

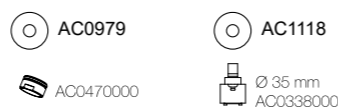

## AC0983

Kg 0,8  
Box pcs 12



Bocca d'erogazione senza deviatore per vasca incasso.

Spout for concealed bath mixer.

Bec pour mitigeur bain/douche encastré.

Zusauslauf für Unterputz-Badebatterie.

3oca de erogación sin desviador para bañera empotrable.

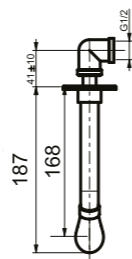

.015 Cromo / Chrome / Chromée / Verchromt / Cromado € 150,00

.560 Nero opaco / Matt black / Noir mat / Matt Schwarz / Negro mate € 165,00

.065 Bronzo / Bronze / Bronze / Bronze / Bronze € 188,00

.010 Oro / Gold / Doré / Gold / Oro € 188,00

.980 Oro rosa / Rose gold / Or rose / Rose gold / Oro rosa € 198,00

Collezione Primavera 2023 € 188,00



## OA500201

Kg 0,9  
Box pcs 10



Porta dosatore sapone liquido a parete in ceramica con pompetta in metallo.

Wall mounted ceramic liquid soap dispenser.

Distributeur de savon liquide mural en céramique.

Seifenspender aus Keramik.

Dosificador de pared cerámico.

.015 Cromo / Chrome / Chromée / Verchromt / Cromado € 152,00

.560 Nero opaco / Matt black / Noir mat / Matt Schwarz / Negro mate € 167,00

.065 Bronzo / Bronze / Bronze / Bronze / Bronze € 186,00

.010 Oro / Gold / Doré / Gold / Oro € 186,00

.980 Oro rosa / Rose gold / Or rose / Rose gold / Oro rosa € 220,00

Collezione Primavera 2023 € 186,00

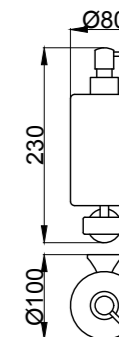

## OA500301

Kg 0,8  
Box pcs 10



Porta bicchiere in ceramica a parete.

Wall mounted ceramic tumbler.

Porte verre en céramique à mur.

Wand Becherhalter aus Keramik.

Portavaso a pared de ceramica.

.015 Cromo / Chrome / Chromée / Verchromt / Cromado € 128,00

.560 Nero opaco / Matt black / Noir mat / Matt Schwarz / Negro mate € 140,00

.065 Bronzo / Bronze / Bronze / Bronze / Bronze € 157,00

.010 Oro / Gold / Doré / Gold / Oro € 157,00

.980 Oro rosa / Rose gold / Or rose / Rose gold / Oro rosa € 165,00

Collezione Primavera 2023 € 157,00

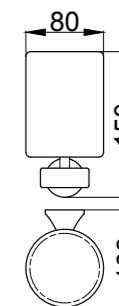

## OA500401

Kg 0,65  
Box pcs 12



Appendino in ottone.

Hook in brass.

Peignoir en laiton.

Haken aus Messing.

Percha en latón.

.015 Cromo / Chrome / Chromée / Verchromt / Cromado € 83,00

.560 Nero opaco / Matt black / Noir mat / Matt Schwarz / Negro mate € 91,00

.065 Bronzo / Bronze / Bronze / Bronze / Bronze € 105,00

.010 Oro / Gold / Doré / Gold / Oro € 105,00

.980 Oro rosa / Rose gold / Or rose / Rose gold / Oro rosa € 110,00

Collezione Primavera 2023 € 105,00

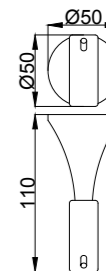

## OA501302

Kg 0,9  
Box pcs 4



Porta scopino ovale in ottone a pavimento.

Free standing brass oval-shaped toilet brush holder.

Porte balai WC au sol ovale, en laiton.

Oval WC-Bürstenständer aus Messing.

Escobillero oval de suelo en latón.

.015 Cromo / Chrome / Chromée / Verchromt / Cromado € 118,00

.560 Nero opaco / Matt black / Noir mat / Matt Schwarz / Negro mate € 130,00

.065 Bronzo / Bronze / Bronze / Bronze / Bronze € 145,00

.010 Oro / Gold / Doré / Gold / Oro € 145,00

.980 Oro rosa / Rose gold / Or rose / Rose gold / Oro rosa € 152,00

Collezione Primavera 2023 € 145,00

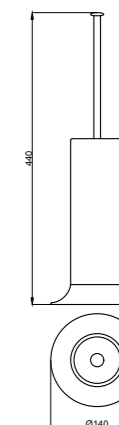

## OA500501

 Kg 1,1  
Box pcs 4



Porta asciugamano in ottone.

Brass towel holder.

Porte serviette en laiton.

Handtuchhalter aus Messing.

Toallero de latón.

.015	Cromo / Chrome / Chromée / Verchromt / Cromado	€ 200,00
.560	Nero opaco / Matt black / Noir mat / Matt Schwarz / Negro mate	€ 220,00
.065	Bronzo / Bronze / Bronze / Bronze / Bronze	€ 250,00
.010	Oro / Gold / Doré / Gold / Oro	€ 250,00
.980	Oro rosa / Rose gold / Or rose / Rose gold / Oro rosa	€ 275,00
	Collezione Primavera 2023	€ 250,00

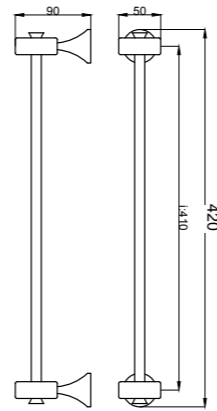

## OA500801

 Kg 0,6  
Box pcs 6



Porta rotolo.

Toilett roll holder.

Support en laiton pour papier rouleaux.

Toilettenpapierhalter aus Messing.

Portarollo de latón.

.015	Cromo / Chrome / Chromée / Verchromt / Cromado	€ 120,00
.560	Nero opaco / Matt black / Noir mat / Matt Schwarz / Negro mate	€ 132,00
.065	Bronzo / Bronze / Bronze / Bronze / Bronze	€ 157,00
.010	Oro / Gold / Doré / Gold / Oro	€ 157,00
.980	Oro rosa / Rose gold / Or rose / Rose gold / Oro rosa	€ 165,00
	Collezione Primavera 2023	€ 157,00

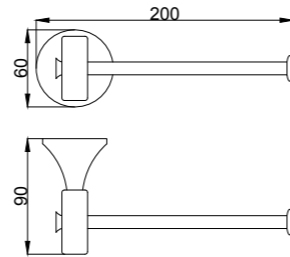

## OA500101

 Kg 0,9  
Box pcs 10



Porta sapone a parete in ceramica.

Wall mounted ceramic soap dish.

Porte savon mural en céramique.

Seifenschale aus Keramik.

Jabonera de pared de ceramica.

.015	Cromo / Chrome / Chromée / Verchromt / Cromado	€ 127,00
.560	Nero opaco / Matt black / Noir mat / Matt Schwarz / Negro mate	€ 140,00
.065	Bronzo / Bronze / Bronze / Bronze / Bronze	€ 166,00
.010	Oro / Gold / Doré / Gold / Oro	€ 166,00
.980	Oro rosa / Rose gold / Or rose / Rose gold / Oro rosa	€ 175,00
	Collezione Primavera 2023	€ 166,00

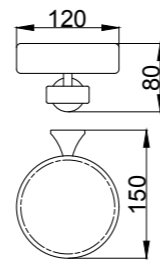

# OPERA MODERNA

Design: Massimiliano Settimelli



OE830101.560  
Miscelatore lavabo.  
One hole basin mixer.

Finiture / finishes / finitions / ausföhrungen / acabados

.015  
Cromo  
Chrome  
Chromé  
Verchromt  
Cromado

.560  
Nero opaco  
Matt black  
Noir mat  
Matt Schwarz  
Negro mate



OE860101.560  
Miscelatore doccia incasso con deviatore.  
2-way built-in shower mixer with diverter.

## OE830101

Kg 2,3  
Box pcs 8



Miscelatore monocomando per lavabo con scarico up & down con flex inox cm 50 att. 3/8" F.

Single lever washbasin mixer with 1"1/4 pop-up waste, with 3/8" F flex. hoses cm 50.

Mitigeur de lavabo avec vidage automatique 1"1/4 et flexibles d'alimentation cm 50 3/8" F.

Einhebelmischer Waschtischbatterie mit Ablaufgarnitur 1"1/4 und flex. Anschlusschläuchen cm 50 3/8" F.

Monomando para lavabo con desagüe 1"1/4, tubo flexible inoxidable de 50 cm, empalme 3/8" F.

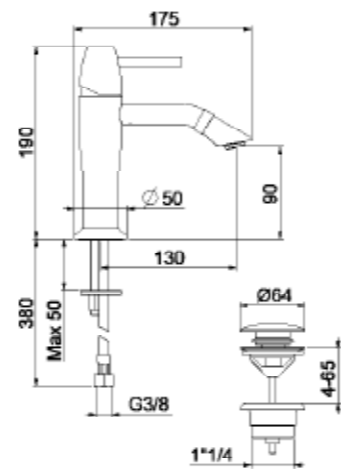

.015 Cromo / Chrome / Chromée / Verchromt / Cromado € 312,00

.560 Nero opaco / Matt black / Noir mat / Matt Schwarz / Negro mate € 343,00

AC0470000

Ø 35 mm  
AC0977000

OE830102

## OE830401

Kg 3,5  
Box pcs 4



Miscelatore monocomando per lavabo alto con scarico up & down, flex inox cm 70 att. 3/8" F.

High single lever washbasin mixer with up & down pop-up waste, with 3/8" flex. hoses 70 cm.

Mitigeur de lavabo haut avec vidage up & down, flexibles d'alimentation cm 70 3/8" F.

Einhebelmischer Waschtischbatterie, mit hoher Ausführung, mit up & down Ablaufgarnitur, mit Flex. Anschlusschläuchen cm 70 3/8" F.

Monomando para lavabo alto con valvula click-clack, tubo flexible inoxidable de 70 cm, empalme 3/8" F.

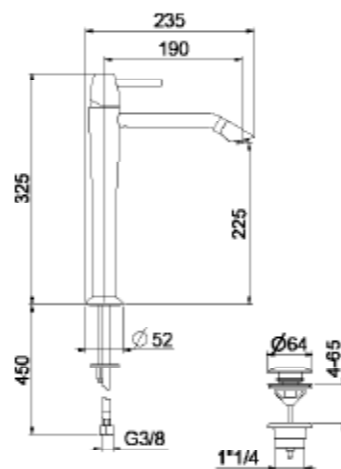

.015 Cromo / Chrome / Chromée / Verchromt / Cromado € 368,00

.560 Nero opaco / Matt black / Noir mat / Matt Schwarz / Negro mate € 415,00

AC0470000

Ø 35 mm  
AC0977000

OE830402

## OE840101

Kg 2  
Box pcs 8



Miscelatore monocomando per bidet con scarico up & down, con flex inox cm 50 att. 3/8" F.

Single lever bidet mixer with up & down pop-up waste, with 3/8" F flex. hoses cm 50.

Mitigeur de bidet avec vidage up & down, flexibles d'alimentation cm 50 3/8" F.

Einhebelmischer Bidetbatterie mit up & down Ablaufgarnitur 1" 1/4, mit flex. Anschlusschläuchen cm 50 3/8" F.

Monomando para bidé con desagüe up & down, tubo flexible inoxidable de 50 cm, empalme 3/8" F.

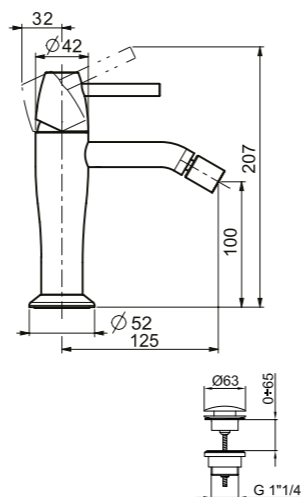

.015 Cromo / Chrome / Chromée / Verchromt / Cromado € 312,00

.560 Nero opaco / Matt black / Noir mat / Matt Schwarz / Negro mate € 343,00

AC0464000

Ø 35 mm  
AC0977000

OE840102

## OE830606

Kg 4  
Box pcs 4



Miscelatore monocomando per lavabo incasso muro, con piastre separate, senza scarico e flessibili.

Concealed single lever washbasin mixer, with 2 cover plates, without pop-up waste and flex hoses.

Mitigeur de lavabo à encastrer, avec 2 rosaces, sans vidage et flexibles.

Einhebelmischer Unterputz-Waschtischbatterie, mit getrennten Platten, ohne Ablaufgarnitur und flex Anschlusschläuchen.

Monomando empotrable para lavabo de pared, con 2 placas, sin desagüe ni tubos flexibles.

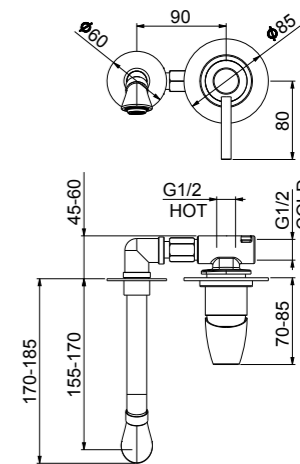

PER FINITURE CONSULTARE  
SEZIONE EASY BATHROOM A PAG. 258

FOR ALL AVAILABLE FINISHINGS  
PLEASE GO TO EASY BATHROOM P. 258

.015 Cromo / Chrome / Chromée / Verchromt / Cromado € 342,00

AC0979015

AC0470000

AC0980015

Ø 35 mm  
AC0338000

## OE880101

Kg 1,6  
Box pcs 12



Miscelatore monocomando per doccia incasso, con piastra, senza flessibile, doccetta e gancio.

Concealed single lever shower mixer with cover plate, without shower set.

Mitigeur de douche à encastrer avec rosace, sans garniture de douche.

Einhebelmischer Unterputz-Brausebatterie, mit Rosette ohne Brausegarnitur.

Monomando empotrable para ducha, con placa, sin tubo flexible, ducha ni gancho.

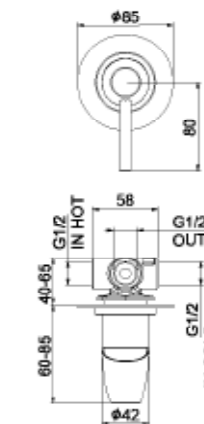

PER FINITURE CONSULTARE  
SEZIONE EASY BATHROOM A PAG. 260

FOR ALL AVAILABLE FINISHINGS  
PLEASE GO TO EASY BATHROOM P. 260

.015 Cromo / Chrome / Chromée / Verchromt / Cromado € 184,00

AC1118

Ø 35 mm  
AC0338000

## OE860101

Kg 2,5  
Box pcs 12



Miscelatore monocomando per vasca incasso con deviatore 2 vie, senza flessibile, doccetta e gancio di supporto.

Concealed single lever bath mixer with 2 ways diverter, without shower set.

Mitigeur bain-douche à encastrer avec inverseur 2 voies, sans garniture de douche.

Einhebelmischer Unterputz-Badebatterie mit 2 Weg Umstellung, ohne Brausegarnitur.

Monomando empotrable para baño-ducha, con desviador 2 vias; sin tubo flexible, ducha ni soporte.

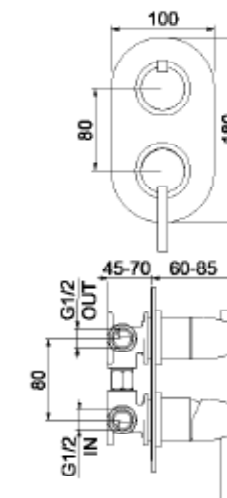

PER FINITURE CONSULTARE  
SEZIONE EASY BATHROOM A PAG. 260

FOR ALL AVAILABLE FINISHINGS  
PLEASE GO TO EASY BATHROOM P. 260

.015 Cromo / Chrome / Chromée / Verchromt / Cromado € 300,00

AC0981

Ø 35 mm  
AC0329000

Ø 35 mm  
AC0338000

## OE860312

Kg 4  
Box pcs 4



Vasca incasso con bocca, deviatore, flessibile e doccia monogetto.

Concealed bath mixer with spout, diverter, flex. hose and monospray handshower.

Mélangeur bain-douche à encastrer avec inverseur, flexible et douche mono-jet.

Unterputz-Badebatterie mit Umstellung, Metallbrauseschlauch und Mono-Wasserstrahl Handbrause.

Bateria bañera empotrable con inversor, flexo y ducha.

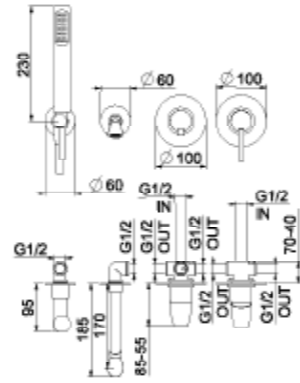

.015 Cromo / Chrome / Chromée / Verchromt / Cromado € 496,00

.560 Nero opaco / Matt black / Noir mat / Matt Schwarz / Negro mate € 545,00



AC0979



AC1180



AC0470000

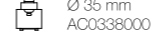

Ø 35 mm  
AC0338000

## AC0983

Kg 0,8  
Box pcs 12



Bocca d'erogazione senza deviatore per vasca incasso.

Spout for concealed bath mixer.

Bec pour mitigeur bain/douche encastré.

Gussauslauf für Unterputz-Badebatterie.

Boca de erogación sin desviador para bañera empotrable.

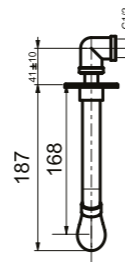

.015 Cromo / Chrome / Chromée / Verchromt / Cromado € 150,00

.560 Nero opaco / Matt black / Noir mat / Matt Schwarz / Negro mate € 165,00



AC0470000



AC0979015

# LIVING

Design: Busetti, Garuti e Redaelli



LV830101.015  
Miscelatore lavabo.  
One hole basin mixer.



LV832101.015  
Miscelatore lavabo a pavimento.  
Floor-mounted basin mixer.



## Finiture / finishes / finitions / ausföhrungen / acabados

.015	.560	.345
Cromo	Nero opaco	Acciaio spazzolato
Chrome	Matt black	Brushed nickel
Chromé	Noir mat	Acier brossé
Verchromt	Matt Schwarz	Edelstahl Optik
Cromado	Negro mate	Acero cepillado

Ideata da M.Busetti, A. Garuti, M.Redaeli, Living è la serie perfetta per chi vuole disegnare lo spazio bagno in base alle esigenze personali. Versatile e personalizzabile, dal design semplice e pulito, permette di riprogettare con semplicità tutti gli elementi della sala bagno. Ogni elemento può essere composto abbinando leve e bocche differenti secondo le esigenze del progettista.



LV720901.015  
Vasca incasso con bocca, deviatore e doccia.  
Concealed bath mixer with spout, diverter and handshower.

Conceived by M.Busetti, A. Garuti, M.Redaeli, Living is the perfect series for those who wants to design their bathroom according to personal needs. Versatile and customisable, with a simple and neat design, it allows to easily rethink all the elements in the bathroom. Every element may be composed combining different levers and spouts according to the designer's necessities.



LV830606.015  
Miscelatore lavabo a muro.  
Wall basin mixer.

LV730401.015  
Gruppo per bordo vasca 5 fori completo.  
5-holes deck mounted bath mixer.



LV971402.015  
Termostatico incasso 2 vie.  
Thermostatic concealed mixer with 2 ways diverter.





## LV830101

Kg 1,9  
Box pcs 8



Miscelatore monocomando per lavabo con scarico up & down, con flex inox cm 37 att. 3/8" F.

Single lever washbasin mixer with up & down pop-up waste, with 3/8" F flex. hoses cm 37.

Mitigeur de lavabo avec vidage up & down, flexibles d'alimentation cm 37 3/8" F.

Einhebelmischer Waschtischbatterie mit up & down Ablaufgarnitur, mit Anschlussschläuchen cm 37 3/8" F.

Monomando para lavabo con valvula click-clack, tubos flexibles de acero inoxidable de 37 cm, 3/8" F.

.015 Cromo / Chrome / Chromée / Verchromt / Cromado € 273,00

.560 Nero opaco / Matt black / Noir mat / Matt Schwarz / Negro mate € 382,00

.345 Acciaio spazzolato / Brushed nickel / Acier brossé / Edelstahl Optik / Acero cepillado € 437,00

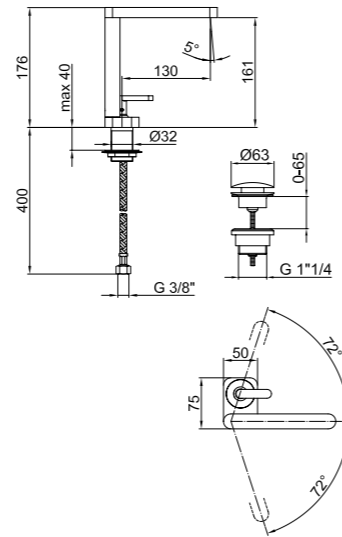

## LV830102

## LV830702

Kg 2,2  
Box pcs 8



Miscelatore monocomando per lavabo alto con scarico up & down, flex inox cm 37 att. 1/2" F.

High single lever washbasin mixer with up & down pop-up waste, with 1/2" flex. hoses 37 cm.

Mitigeur de lavabo haut avec vidage up & down, flexibles d'alimentation cm 37 1/2" F.

Einhebelmischer Waschtischbatterie, mit hoher Ausführung, mit up & down Ablaufgarnitur und Anschlussschläuchen cm 37 1/2" F.

Monomando para lavabo alto con valvula click-clack, tubos flexibles de acero inoxidable de 37 cm, 1/2" F.

.015 Cromo / Chrome / Chromée / Verchromt / Cromado € 350,00

.560 Nero opaco / Matt black / Noir mat / Matt Schwarz / Negro mate € 490,00

.345 Acciaio spazzolato / Brushed nickel / Acier brossé / Edelstahl Optik / Acero cepillado € 560,00

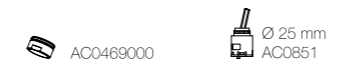
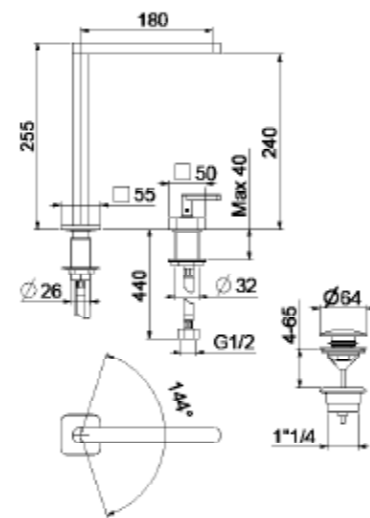

## LV832101

Kg 13  
Box pcs 1

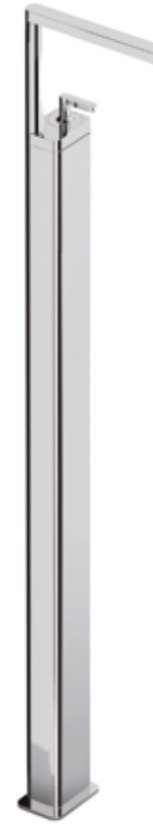

Miscelatore monocomando per lavabo a pavimento.

Single lever floor mounted basin mixer.

Mitigeur lavabo au sol.

Einhebelmischer Stand-Waschtischbatterie.

Monomando de pie para lavabo.

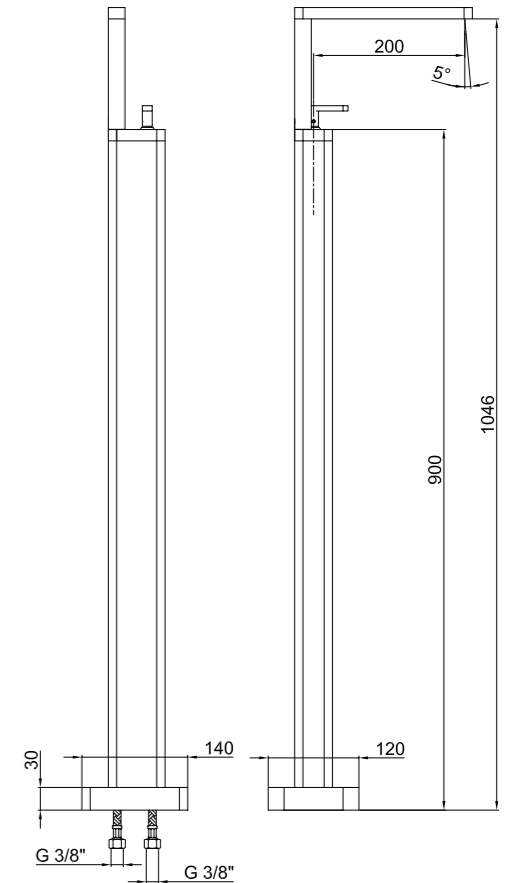

.015 Cromo / Chrome / Chromée / Verchromt / Cromado € 965,00

.560 Nero opaco / Matt black / Noir mat / Matt Schwarz / Negro mate € 1.330,00

.345 Acciaio spazzolato / Brushed nickel / Acier brossé / Edelstahl Optik / Acero cepillado € 1.520,00



## LV830606 mm 160

## LV832506 mm 200

Kg 2,3  
Box pcs 8



Miscelatore monocomando per lavabo incasso muro, con piastra orizzontale, senza scarico e flessibili.

Concealed single lever washbasin mixer, horizontal cover plate, without pop-up waste and flex hoses.

Mitigeur de lavabo à encastrer, rosace horizontale, sans vidage et flexibles.

Einhebelmischer Unterputz-Waschtischbatterie waagerechte Rosette, ohne Ablaufgarnitur und Anschlussschläuchen.

Monomando empotrable para lavabo, de pared, con placa horizontal, sin desagüe ni tubos flexibles.

.015 Cromo / Chrome / Chromée / Verchromt / Cromado € 350,00

.560 Nero opaco / Matt black / Noir mat / Matt Schwarz / Negro mate € 490,00

.345 Acciaio spazzolato / Brushed nickel / Acier brossé / Edelstahl Optik / Acero cepillado € 560,00

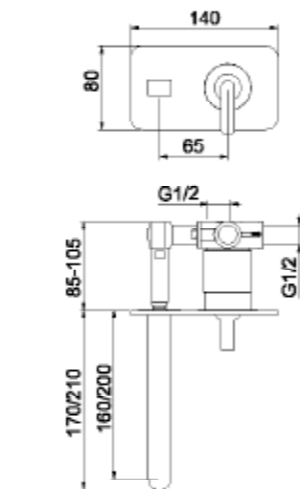

## LV840101

Kg 1,9  
Box pcs 8



Miscelatore monocomando per bidet con scarico up & down, con flex inox cm 37 att. 3/8" F.

Single lever bidet mixer with up & down pop-up waste, with 3/8" F flex. hoses cm 37.

Mitigeur de bidet avec vidage up & down, flexibles d'alimentation cm 37 3/8" F.

Einhebelmischer Bidetbatterie mit up & down Ablaufgarnitur 1" 1/4, mit Anschlussschläuchen cm 37 3/8" F.

Monomando para bidé con valvula click-clack, tubos flexibles de acero inoxidable de 37 cm, 3/8" F.

.015 Cromo / Chrome / Chromée / Verchromt / Cromado € 273,00

.560 Nero opaco / Matt black / Noir mat / Matt Schwarz / Negro mate € 382,00

.345 Acciaio spazzolato / Brushed nickel / Acier brossé / Edelstahl Optik / Acero cepillado € 437,00

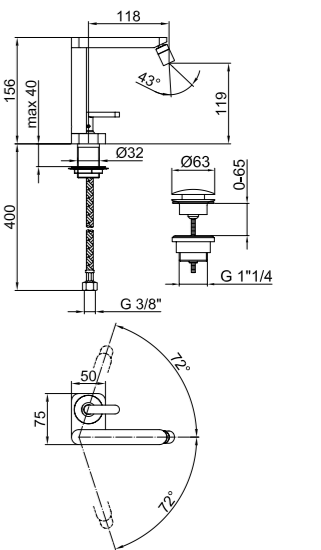

## LV880101

Kg 1,3  
Box pcs 12



Miscelatore monocomando per doccia incasso, con piastra, senza flessibile, doccetta e gancio.

Concealed single lever shower mixer with cover plate, without shower set.

Mitigeur de douche à encastrer avec rosace, sans garniture de douche.

Einhebelmischer Unterputz-Brausebatterie, mit Rosette ohne Brausegarnitur.

Monomando empotrable para ducha, con placa, sin tubo flexible, ducha ni gancho.

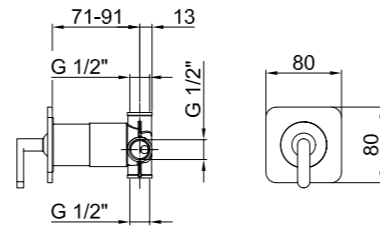

- .015 Cromo / Chrome / Chromée / Verchromt / Cromado € 225,00
- .560 Nero opaco / Matt black / Noir mat / Matt Schwarz / Negro mate € 315,00
- .345 Acciaio spazzolato / Brushed nickel / Acier brossé / Edelstahl Optik / Acero cepillado € 360,00



## LV860101

Kg 1,8  
Box pcs 12



Miscelatore monocomando per vasca incasso con deviatore 2 vie, senza flessibile, doccetta e gancio di supporto.

Concealed single lever bath mixer with 2 ways diverter, without shower set.

Mitigeur bain-douche à encastrer avec inverseur 2 voies, sans garniture de douche.

Einhebelmischer Unterputz-Badebatterie mit 2 Weg Umstellung, ohne Brausegarnitur.

Monomando empotrable para baño-ducha, con desviador 2 vías; sin tubo flexible, ducha ni soporte.

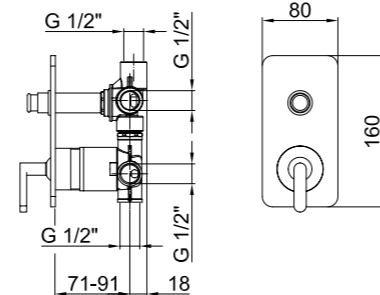

- .015 Cromo / Chrome / Chromée / Verchromt / Cromado € 350,00
- .560 Nero opaco / Matt black / Noir mat / Matt Schwarz / Negro mate € 490,00
- .345 Acciaio spazzolato / Brushed nickel / Acier brossé / Edelstahl Optik / Acero cepillado € 560,00

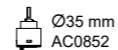

## LV720901

Kg 10  
Box pcs 4



Vasca incasso con bocca, deviatore, flessibile e doccetta monogetto.

Concealed bath mixer with spout, diverter, flex. hose and monospray handshower.

Mélangeur bain-douche à encastrer avec inverseur, flexible et douchette mono-jet.

Unterputz-Badebatterie mit Umstellung, Metallbrauseschlauch und Mono-Wasserstrahl Handbrause.

Bateria bañera empotrable con desviador, flexible y ducha.

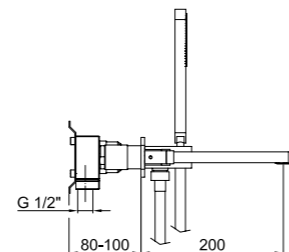
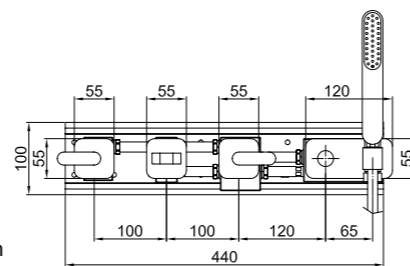

- .015 Cromo / Chrome / Chromée / Verchromt / Cromado € 965,00
- .560 Nero opaco / Matt black / Noir mat / Matt Schwarz / Negro mate € 1.302,00
- .345 Acciaio spazzolato / Brushed nickel / Acier brossé / Edelstahl Optik / Acero cepillado € 1.488,00



## LV851101

Kg 13  
Box pcs 1

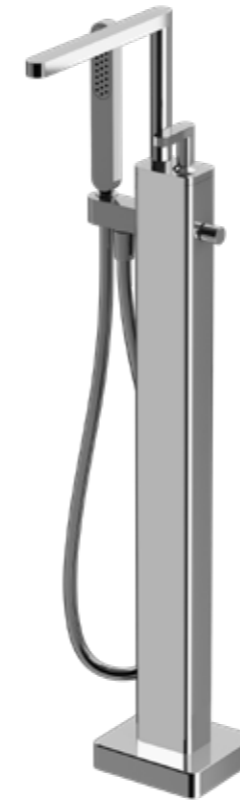

Miscelatore monocomando per vasca a pavimento con flessibile, doccetta.

Single lever floor bath mixer with flexible hose, handshower.

Mitigeur baignoire au sol avec flexible, douchette.

Einhebelmischer Stand-Badebatterie mit Brauseschlauch, Handbrause.

Monomando para bañera de pie, con flexible y ducha.

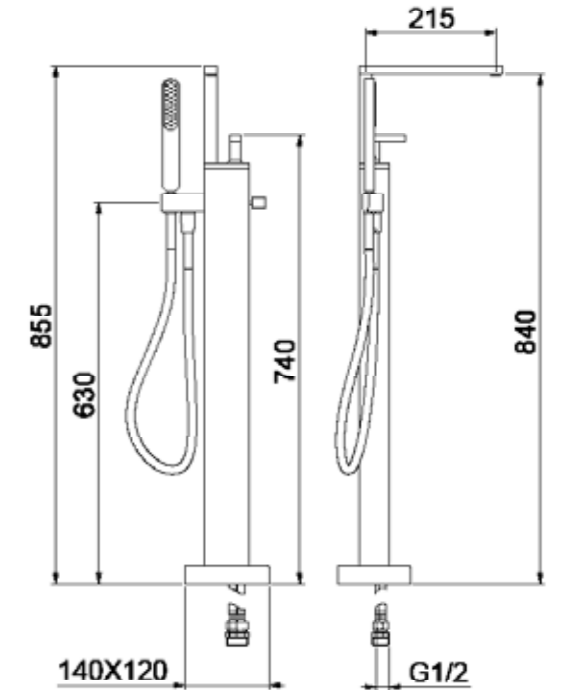

- .015 Cromo / Chrome / Chromée / Verchromt / Cromado € 1.070,00
- .560 Nero opaco / Matt black / Noir mat / Matt Schwarz / Negro mate € 1.498,00
- .345 Acciaio spazzolato / Brushed nickel / Acier brossé / Edelstahl Optik / Acero cepillado € 1.712,00

## LV730401

Kg 5,6  
Box pcs 4



Gruppo per bordo vasca 5 fori completo con flessibile in gomma da 200 cm e doccetta.

5-holes deck mounted bath mixer complete of hose 200 cm and handshower.

Mélangeur bain-douche 5-trous, flexible 200 cm et douchette.

5-Loch-Wannenrandarmatur mit Brauseschlauch 200 cm. und Handbrause.

Grupo para borde de bañera, 5 agujeros, flexible y ducha.

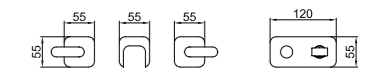
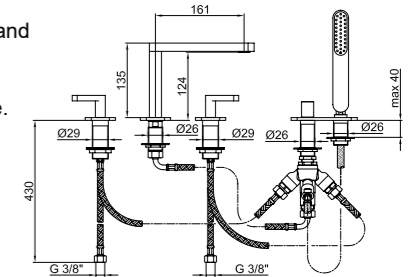

- .015 Cromo / Chrome / Chromée / Verchromt / Cromado € 735,00
- .560 Nero opaco / Matt black / Noir mat / Matt Schwarz / Negro mate € 1.029,00
- .345 Acciaio spazzolato / Brushed nickel / Acier brossé / Edelstahl Optik / Acero cepillado € 1.176,00



## LV971302

Kg 6  
Box pcs 2



Termostatico incasso a parete alte portate con 1 via.

Thermostatic concealed high flow- rate mixer with 1 way diverter.

Mitigeur thermostatique haut-débit à encastrer avec 1 voies.

Thermostat Unterputz HD Mischer mit 1 Wegeumsteller.

Termostático empotrable alto caudal 1 vía.

.015 Cromo / Chrome / Chromée / Verchromt / Cromado € 690,00

.560 Nero opaco / Matt black / Noir mat / Matt Schwarz / Negro mate € 966,00

.345 Acciaio spazzolato / Brushed nickel / Acier brossé / Edelstahl Optik / Acero cepillado € 1.104,00

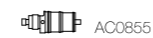
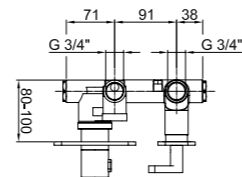
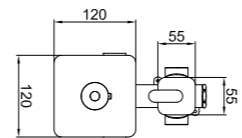
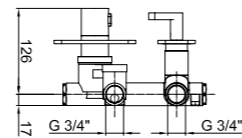

## LV971402

Kg 6,5  
Box pcs 2



Termostatico incasso a parete alte portate con 2 vie.

Thermostatic concealed high flow- rate mixer with 2 ways diverter.

Mitigeur thermostatique haut-débit à encastrer avec 2 voies.

Thermostat Unterputz HD Mischer mit 2 Wegeumsteller.

Termostático empotrable alto caudal 2 vías.

.015 Cromo / Chrome / Chromée / Verchromt / Cromado € 800,00

.560 Nero opaco / Matt black / Noir mat / Matt Schwarz / Negro mate € 1.120,00

.345 Acciaio spazzolato / Brushed nickel / Acier brossé / Edelstahl Optik / Acero cepillado € 1.280,00

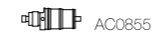
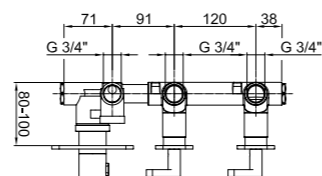
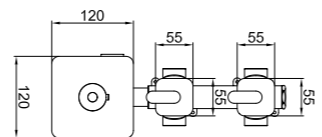
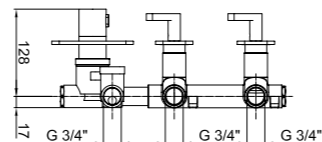

## LV971502

Kg 7  
Box pcs 2

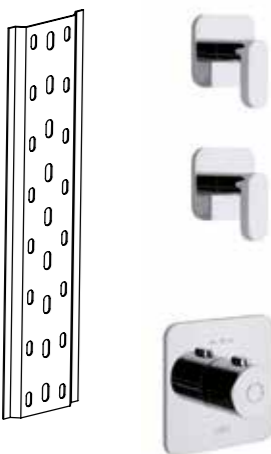

Termostatico incasso a parete alte portate con 3 vie.

Thermostatic concealed high flow- rate mixer with 3 ways diverter.

Mitigeur thermostatique haut-débit à encastrer avec 3 voies.

Thermostat Unterputz HD Mischer mit 3 Wegeumsteller.

Termostático empotrable alto caudal 3 vías.

.015 Cromo / Chrome / Chromée / Verchromt / Cromado € 880,00

.560 Nero opaco / Matt black / Noir mat / Matt Schwarz / Negro mate € 1.232,00

.345 Acciaio spazzolato / Brushed nickel / Acier brossé / Edelstahl Optik / Acero cepillado € 1.408,00

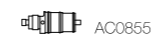
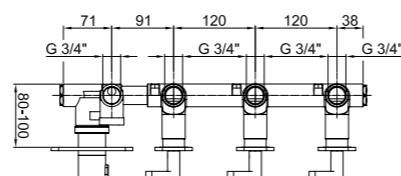
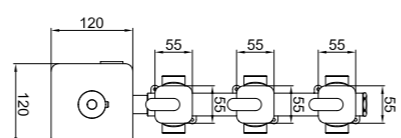
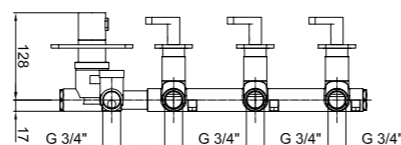

# WOLO

Design: Massimiliano Settimelli



WO830101.015  
Miscelatore lavabo.  
One hole basin mixer.

Finiture / finishes / finitions / ausföhrungen / acabados

.015  
Cromo  
Chrome  
Chromé  
Verchromt  
Cromado

.564  
Nero opaco-Cromo  
Matt black-Chrome  
Noir mat-Chromé  
Matt schwarz-Verchromt  
Negro mate-Cromado



WO660302.015  
Colonna doccia esterno.  
External column with shower mixer.

Aerodinamicità e leggerezza sono le idee ispiratrici della linea WOLO, disegnata da Massimiliano Settimelli. Il suo corpo affusolato e slanciato si assottiglia esattamente come l'ala di un aereo, mentre nel gruppo vasca, sviluppo orizzontale e slancio verticale sembrano cogliere l'attimo iniziale del volo. Con il nero opaco, il bianco opaco e l'oro satinato, la linea Wolo spicca un salto verso le nuove tendenze.

Aerodynamics and lightness are the inspiring ideas of the WOLO series, designed by Massimiliano Settimelli. Its tapering slender body grows thinner just like an airplane wing. Whereas in the bath filler tap the horizontal expansion and the vertical soaring lines seem to seize the initial moment of the flight. In matt black, matt white and satin finish gold, Wolo series leaps towards new trends.



## WO830101

Kg 1,9  
Box pcs 8



Miscelatore monocomando per lavabo con scarico up & down, con flex inox cm 37 att. 3/8" F.

Single lever washbasin mixer with up & down pop-up waste, with 3/8" F flex. hoses cm 37.

Mitigeur de lavabo avec vidage up & down, flexibles d'alimentation cm 37 3/8" F.

Einhebelmischer Waschtischbatterie mit up & down Ablaufgarnitur, mit Anschlusschläuchen cm 37 3/8" F.

Monomando para lavabo con valvula click-clack, tubos flexibles de acero inoxidable de 37 cm, 3/8" F.

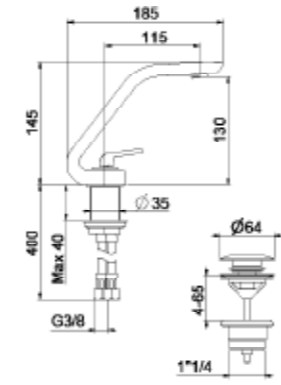

SPECIAL AERATOR

.015 Cromo / Chrome / Chromée / Verchromt / Cromado € 322,00

.564 Nero opaco-Cromo / Matt black-Chrome / Noir mat-Chromée / Matt Schwarz-Verchromt / Negro mate-Cromado € 360,00

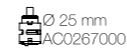

WO830102



## WO830401

Kg 2,3  
Box pcs 8



Miscelatore monocomando per lavabo alto con scarico up & down, flex inox cm 37 att. 1/2" F.

High single lever washbasin mixer with up & down pop-up waste, with 1/2" flex. hoses 37 cm.

Mitigeur de lavabo haut avec vidage up & down, flexibles d'alimentation cm 37 1/2" F.

Einhebelmischer Waschtischbatterie, mit hoher Ausführung, mit up & down Ablaufgarnitur und Anschlusschläuchen cm 37 1/2" F.

Monomando para lavabo alto con valvula click-clack, tubos flexibles de acero inoxidable de 37 cm, 1/2" F.

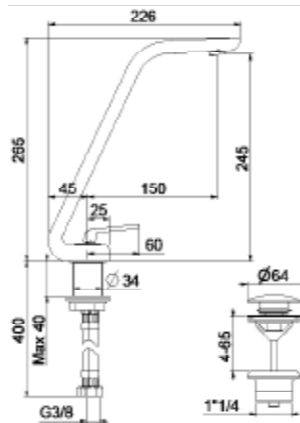

SPECIAL AERATOR

.015 Cromo / Chrome / Chromée / Verchromt / Cromado € 390,00

.564 Nero opaco-Cromo / Matt black-Chrome / Noir mat-Chromée / Matt Schwarz-Verchromt / Negro mate-Cromado € 436,00



WO830402



## WO830607

Kg 2,7  
Box pcs 8



Miscelatore monocomando per lavabo incasso muro, con piastra, senza scarico e flessibili.

Concealed single lever washbasin mixer, with cover plate, without pop-up waste and flex hoses.

Mitigeur de lavabo à encastrer, avec rosace, sans vidage et flexibles.

Einhebelmischer Unterputz-Waschtischbatterie, mit Rosette, ohne Ablaufgarnitur und flex Anschlusschläuchen.

Monomando empotrable para lavabo de pared, con placa, sin desagüe ni tubos flexibles.

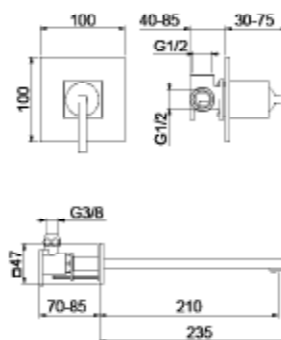

.015 Cromo / Chrome / Chromée / Verchromt / Cromado € 425,00

.564 Nero opaco-Cromo / Matt black-Chrome / Noir mat-Chromée / Matt Schwarz-Verchromt / Negro mate-Cromado € 472,00



## WO840101

Kg 1,9  
Box pcs 8



Miscelatore monocomando per bidet con scarico up & down, con flex inox cm 37 att. 3/8" F.

Single lever bidet mixer with up & down pop-up waste, with 3/8" F flex. hoses cm 37.

Mitigeur de bidet avec vidage up & down, flexibles d'alimentation cm 37 3/8" F.

Einhebelmischer Bidetbatterie mit up & down Ablaufgarnitur 1" 1/4, mit flex. Anschlusschläuchen cm 37 3/8" F.

Monomando para bidé con desagüe up & down, tubo flexible inoxidable de 37 cm, empalme 3/8" F.

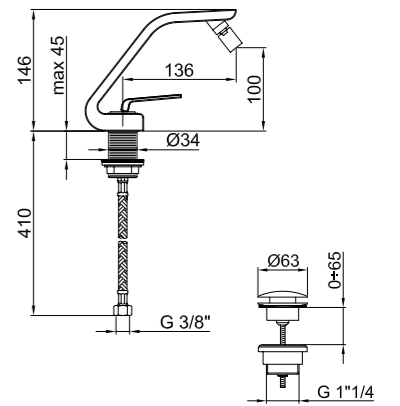

.015 Cromo / Chrome / Chromée / Verchromt / Cromado € 322,00

.564 Nero opaco-Cromo / Matt black-Chrome / Noir mat-Chromée / Matt Schwarz-Verchromt / Negro mate-Cromado € 360,00



WO840102

## WO880101

Kg 1,6  
Box pcs 8



Miscelatore monocomando per doccia incasso, con piastra, senza flessibile, doccetta e gancio.

Concealed single lever shower mixer with cover plate, without shower set.

Mitigeur de douche à encastrer avec rosace, sans garniture de douche.

Einhebelmischer Unterputz-Brausebatterie, mit Rosette ohne Brausegarnitur.

Monomando empotrable para ducha, con placa, sin tubo flexible, ducha ni gancho.

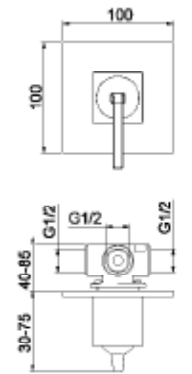

.015 Cromo / Chrome / Chromée / Verchromt / Cromado € 190,00

.564 Nero opaco-Cromo / Matt black-Chrome / Noir mat-Chromée / Matt Schwarz-Verchromt / Negro mate-Cromado € 213,00

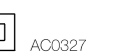
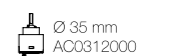

## WO860101

Kg 2,4  
Box pcs 8



Miscelatore monocomando per vasca incasso, con deviatore automatico e piastra, senza flessibile, doccetta e gancio di supporto.

Concealed single lever bath mixer with automatic diverter, cover plate, without shower set.

Mitigeur bain-douche à encastrer avec inverseur automatique, rosace, sans garniture de douche.

Einhebelmischer Unterputz-Badebatterie mit Umstellung, Rosette, ohne Brausegarnitur.

Monomando empotrable para bañera, con desviador automático, placa, sin tubo flexible, ducha ni gancho de soporte.

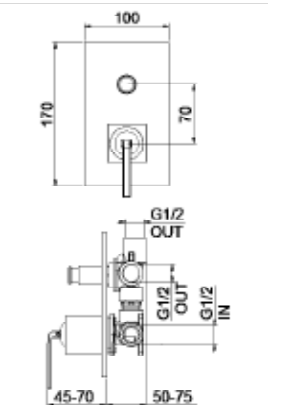

.015 Cromo / Chrome / Chromée / Verchromt / Cromado € 324,00

.564 Nero opaco-Cromo / Matt black-Chrome / Noir mat-Chromée / Matt Schwarz-Verchromt / Negro mate-Cromado € 362,00

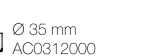
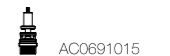

## WO850101

 Kg 4,2  
Box pcs 4



Miscelatore monocomando per vasca esterno completo con flessibile da 150 cm, doccia anticalcare e supporto.

Single lever bath mixer with shower set complete of hose 150 cm, handshower and holder.

Mitigeur bain-douche complet de flexible 150 cm, douchette et support mural.

Einhebelmischer Badebatterie mit Brausegarnitur bestehend aus Brauseschlauch 150 cm, Handbrause und Wandhalterung.

Monomando externo para bañera completo, con tubo flexible de 150 cm, ducha antical y soporte.

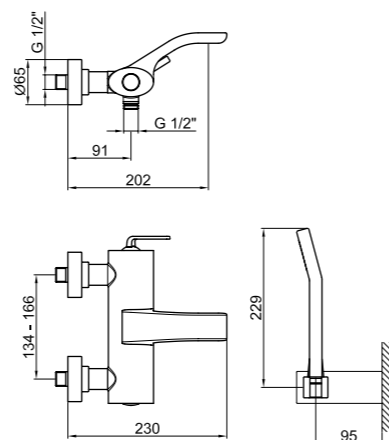

.015 Cromo / Chrome / Chromée / Verchromt / Cromado € 389,00

.564 Nero opaco-Cromo / Matt black-Chrome / Noir mat-Chromée / Matt Schwarz-Verchromt / Negro mate-Cromado € 435,00



AC1197



AC0743000

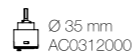

Ø 35 mm  
AC0312000

 + € 15,00

## WO850701

 Kg 5,2  
Box pcs 4



Gruppo per bordo vasca 4 fori completo con flessibile da 150 cm e doccia.

4-holes deck mounted bath mixer complete of hose 150 cm and handshower.

Mitigeur bain-douche 4-trous, flexible 150 cm et douchette.

4-Loch-Wannenrandarmatur mit Metallbrauseschlauch 150 cm. und Handbrause.

Grupo para borde de bañera, 4 agujeros, con tubo flexible, longitud 150 cm y ducha.

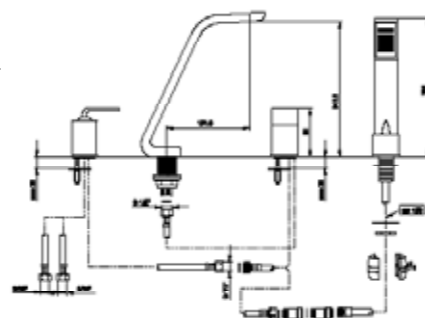

.015 Cromo / Chrome / Chromée / Verchromt / Cromado € 606,00

.564 Nero opaco-Cromo / Matt black-Chrome / Noir mat-Chromée / Matt Schwarz-Verchromt / Negro mate-Cromado € 649,00



flex  
AC0744

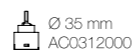

Ø 35 mm  
AC0312000



AC0470000



AC0329000

Diametro foratura pannello vasca A-B-C-D = 35 mm  
Massimo spessore pannello vasca 35 mm

Diameter of the bath deck drilling A-B-C-D = 35 mm  
Largest thickness of the bath deck 35 mm

Diamètre perçage du bord de la baignoire A-B-C-D=35 mm  
Maximum épaisseur du bord de la baignoire 35 mm

Bohrungsdurchmesser der Wannenrandarmatur A-B-C-D=35 mm  
Grösste Dicke der Wannenrandarmatur 35 mm

Diámetro agujero borde de bañera A-B-C-D = 35 mm  
Máximo espesor borde de bañera 35 mm

## AC0324

 Kg 1,2  
Box pcs 12



Bocca d'erogazione senza deviatore per vasca incasso.

Spout for concealed bath mixer.

Bec pour mitigeur bain/douche encastré.

Gussauslauf für Unterputz-Badebatterie.

Boca de erogación sin desviador para bañera empotrable.

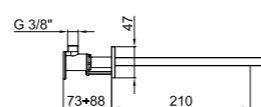

.015 Cromo / Chrome / Chromée / Verchromt / Cromado € 242,00

.564 Nero opaco-Cromo / Matt black-Chrome / Noir mat-Chromée / Matt Schwarz-Verchromt / Negro mate-Cromado € 269,00



AC0470000

## WO500201

 Kg 1,5  
Box pcs 10



Porta dosatore sapone liquido a parete in ceramica con pompetta in metallo.

Wall mounted ceramic liquid soap dispenser.

Distributeur de savon liquide à mur en céramique.

Wand Seifenspendler aus Keramik.

Dosificador de pared cerámico.

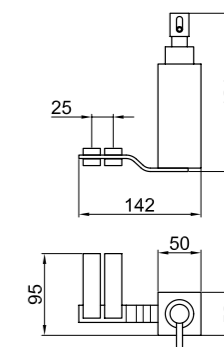

.015 Cromo / Chrome / Chromée / Verchromt / Cromado € 200,00

## WO500301

 Kg 1  
Box pcs 10



Porta bicchiere in ceramica a parete.

Wall mounted ceramic tumbler.

Porte verre en céramique à mur.

Wand Becherhalter aus Keramik.

Portavaso de pared cerámica.

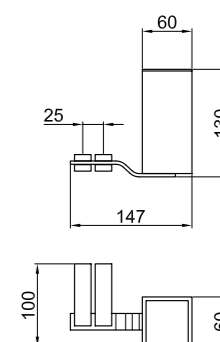

.015 Cromo / Chrome / Chromée / Verchromt / Cromado € 167,00

## WO500401

 Kg 0,5  
Box pcs 12



Appendino in ottone.

Brass hook.

Peignoir en laiton.

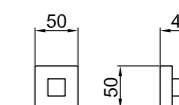

Haken aus Messing.

Percha en latón.



.015 Cromo / Chrome / Chromée / Verchromt / Cromado € 82,00

### WO500501

 Kg 1,4  
 Box pcs 4

Porta asciugamano in ottone.

Brass towel holder.

Porte serviette en laiton.

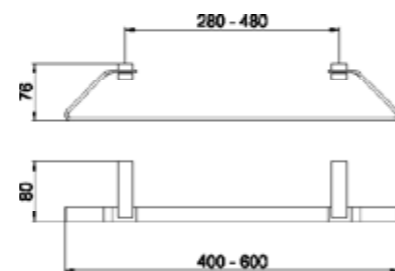

Handtuchhalter aus Messing.

Toallero de latón.



.015 Cromo / Chrome / Chromée / Verchromt / Cromado € 155,00

### WO500801

 Kg 0,9  
 Box pcs 10

Porta rotolo.

Toilet roll holder.

Support en laiton pour papier rouleaux.

Toilettenpapierhalter.

Portarollo de latón.

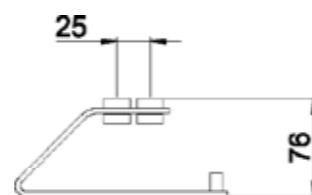

.015 Cromo / Chrome / Chromée / Verchromt / Cromado € 96,00



WO850101.015  
Miscelatore vasca.  
One hole bath mixer.

# ELIO



Finiture / finishes / finitions / ausföhrungen / acabados

.015  
Cromo  
Chrome  
Chromé  
Verchromt  
Cromado

.560  
Nero opaco  
Matt black  
Noir mat  
Matt schwarz  
Negro mate

.345  
Acciaio spazzolato  
Brushed nickel  
Acier brossé  
Edelstahl Optik  
Acero cepillado

Color Lab

EL830101.015  
Miscelatore lavabo.  
One hole basin mixer.



AC0984.845  
Soffione in acciaio inox.  
Stainless steel shower head.



EL971402.015  
Termostatico incasso 2 vie.  
Thermostatic concealed mixer with 2-way diverter.

AC0982.015  
Kit doccia con supporto e presa acqua.  
Shower set with holder and wall elbow.



# COLOR

## *Lab*

ELIO

NERO OPACO \_ OCRA  
MATT BLACK \_\_\_\_\_



## EL830101

Kg 2,1  
Box pcs 12



Miscelatore monocomando per lavabo con scarico 1"1/4 con flex inox cm 50 att. 3/8" F.

Single lever washbasin mixer with 1"1/4 pop-up waste and 3/8" F flex. hoses cm 50.

Mitigreur de lavabo avec vidage automatique 1"1/4 et flexibles d'alimentation cm 50 3/8" F.

Einhebelmischer Waschtischbatterie mit Ablaufgarnitur 1" 1/4 und flex. Anschlussschläuchen cm 50 3/8" F.

Monomando para lavabo con desagüe 1"1/4, tubo flexible inoxidable de 50 cm, empalme 3/8" F.

.015 Cromo / Chrome / Chromée / Verchromt / Cromado € 201,00

.560 Nero opaco / Matt black / Noir mat/ Matt Schwarz / Negro mate € 281,00

.345 Acciaio spazzolato / Brushed nickel / Acier brossé / Edelstahl Optik / Acero cepillado € 322,00

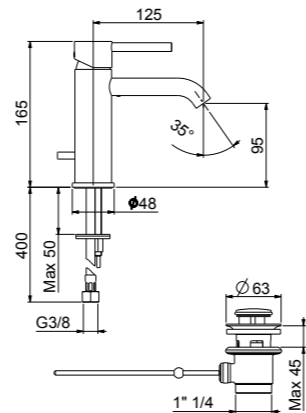

EL830102

## EL830201

Kg 2,1  
Box pcs 12



Miscelatore monocomando per lavabo con scarico up & down con flex inox cm 50 att. 3/8" F.

Single lever washbasin mixer with up & down pop-up waste and 3/8" F flex. hoses cm 50.

Mitigreur de lavabo avec vidage up & down et flexibles d'alimentation cm 50 3/8" F.

Einhebelmischer Waschtischbatterie mit up & down Ablaufgarnitur und flex. Anschlussschläuchen cm 50 3/8" F.

Monomando para lavabo con valvula click clack, tubo flexible inoxidable de 50 cm, empalme 3/8" F.

.015 Cromo / Chrome / Chromée / Verchromt / Cromado € 230,00

.560 Nero opaco / Matt black / Noir mat/ Matt Schwarz / Negro mate € 323,00

.345 Acciaio spazzolato / Brushed nickel / Acier brossé / Edelstahl Optik / Acero cepillado € 370,00

Color Lab € 338,00

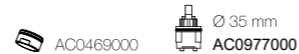
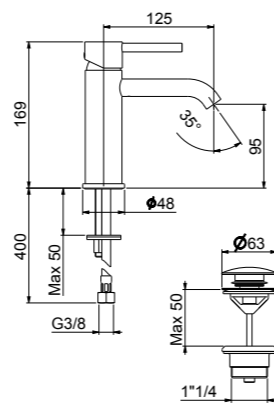

EL830202

## EL830401

Kg 2,7  
Box pcs 10



Miscelatore monocomando per lavabo alto con scarico up & down, flex inox cm 70 att. 3/8" F.

High single lever washbasin mixer with up & down pop-up waste, with 3/8" flex. hoseS 70 cm.

Mitigreur de lavabo haut avec vidage up & down, flexibles d'alimentation cm 70 3/8" F.

Einhebelmischer Waschtischbatterie, mit hoher Ausführung, mit up & down Ablaufgarnitur, mit Flex. Anschlussschläuchen cm 70 3/8" F.

Monomando para lavabo alto con valvula click-clack, tubo flexible inoxidable de 70 cm, empalme 3/8" F.

.015 Cromo / Chrome / Chromée / Verchromt / Cromado € 214,00

.560 Nero opaco / Matt black / Noir mat/ Matt Schwarz / Negro mate € 300,00

.345 Acciaio spazzolato / Brushed nickel / Acier brossé / Edelstahl Optik / Acero cepillado € 342,00

Color Lab € 315,00

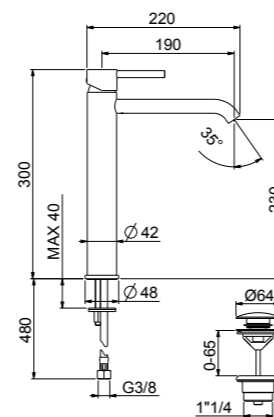

EL830402

## EL830606

Kg 2,1  
Box pcs 12



Miscelatore monocomando per lavabo incasso muro, con piastra, senza scarico e flessibili.

Concealed single lever washbasin mixer, with cover plate, without pop-up waste and flex hoses.

Mitigreur de lavabo à encastrer, avec rosace, sans vidage et flexibles.

Einhebelmischer Unterputz-Waschtischbatterie, mit Rosette, ohne Ablaufgarnitur und flex Anschlussschläuchen.

Monomando empotrable para lavabo de pared, con placa, sin desagüe ni tubos flexibles.

.015 Cromo / Chrome / Chromée / Verchromt / Cromado € 207,00

PER FINITURE CONSULTARE SEZIONE EASY BATHROOM A PAG. 260

FOR ALL AVAILABLE FINISHINGS PLEASE GO TO EASY BATHROOM P. 260

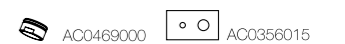
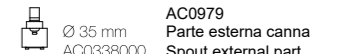
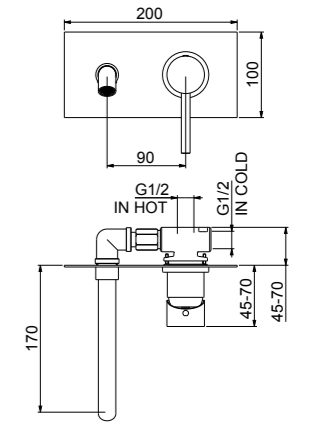

## EL830609

Kg 2,1  
Box pcs 12



Miscelatore monocomando per lavabo incasso muro, con piastre separate, senza scarico e flessibili.

Concealed single lever washbasin mixer, with 2 cover plates, without pop-up waste and flex hoses.

Mitigreur de lavabo à encastrer, avec 2 rosaces, sans vidage et flexibles.

Einhebelmischer Unterputz-Waschtischbatterie, mit getrennten Platten, ohne Ablaufgarnitur und flex Anschlussschläuchen.

Monomando empotrable para lavabo de pared, con 2 placas, sin desagüe ni tubos flexibles.

.015 Cromo / Chrome / Chromée / Verchromt / Cromado € 207,00

PER FINITURE CONSULTARE SEZIONE EASY BATHROOM A PAG. 260

FOR ALL AVAILABLE FINISHINGS PLEASE GO TO EASY BATHROOM P. 260

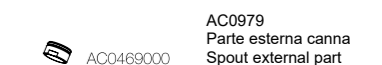
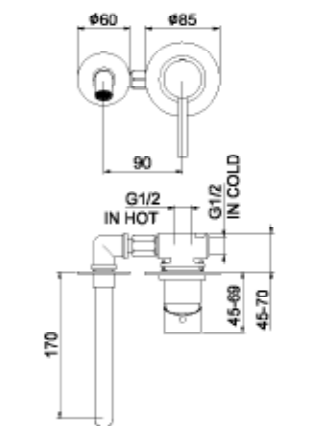

EL840102

## EL840101

Kg 2,1  
Box pcs 12



Miscelatore monocomando per bidet con scarico 1"1/4 con flex inox cm 50 att. 3/8" F.

Single lever bidet mixer with 1"1/4 pop-up waste and 3/8" F flex. hoses cm 50.

Mitigreur de bidet avec vidage automatique 1"1/4 et flexibles d'alimentation cm 50 3/8" F.

Einhebelmischer Bidetbatterie mit Ablaufgarnitur 1" 1/4 und flex. Anschlussschläuchen cm 50 3/8" F.

Monomando para bidé con desagüe 1" 1/4, tubo flexible inoxidable de 50 cm, empalme 3/8" F.

.015 Cromo / Chrome / Chromée / Verchromt / Cromado € 201,00

.560 Nero opaco / Matt black / Noir mat/ Matt Schwarz / Negro mate € 281,00

.345 Acciaio spazzolato / Brushed nickel / Acier brossé / Edelstahl Optik / Acero cepillado € 322,00

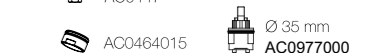
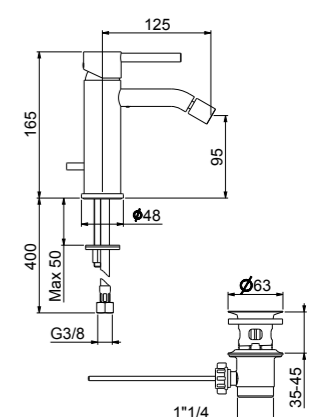

## EL840201

Kg 2,1  
Box pcs 12



Miscelatore monocomando per bidet con scarico up & down con flex inox cm 50 att. 3/8" F.

Single lever bidet mixer with up & down pop-up waste and 3/8" F flex. hoses cm 50.

Mitigeur de bidet avec vidage up & down et flexibles d'alimentation cm 50 3/8" F.

Einhebelmischer Bidetbatterie mit up & down Ablaufgarnitur und flex. Anschlussschläuchen cm 50 3/8" F.

Monomando para bidé con desagüe up & down, tubo flexible inoxidable de 50 cm, empalme 3/8" F.

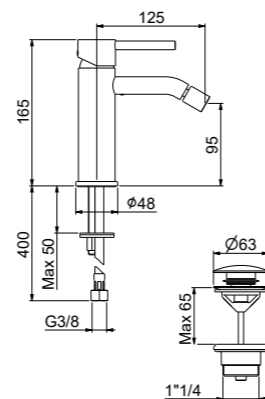

.015	Cromo / Chrome / Chromée / Verchromt / Cromado	€ 230,00
.560	Nero opaco / Matt black / Noir mat/ Matt Schwarz / Negro mate	€ 323,00
.345	Acciaio spazzolato / Brushed nickel / Acier brossé / Edelstahl Optik / Acero cepillado	€ 370,00
	Color Lab	€ 338,00



EL840202

## EL832101

Kg 14  
Box pcs 1



Miscelatore monocomando per lavabo a pavimento.

Single lever floor mounted basin mixer.

Mitigeur lavabo au sol.

Einhebelmischer Stand-Waschtischbatterie.

Monomando para lavabo de suelo.

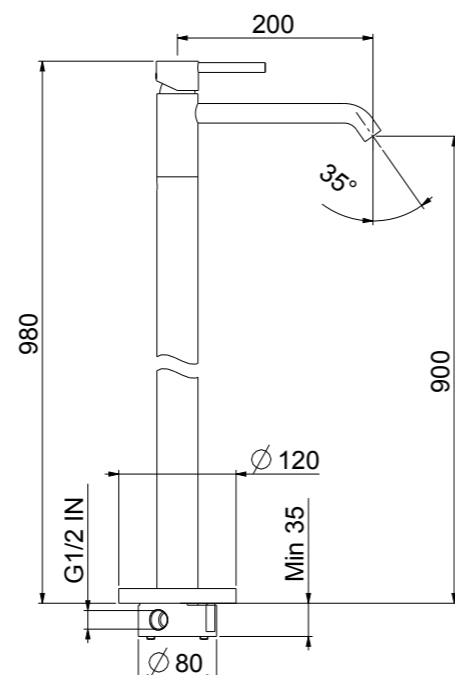

.015	Cromo / Chrome / Chromée / Verchromt / Cromado	€ 865,00
.560	Nero opaco / Matt black / Noir mat/ Matt Schwarz / Negro mate	€ 1.211,00
.345	Acciaio spazzolato / Brushed nickel / Acier brossé / Edelstahl Optik / Acero cepillado	€ 1.384,00
	Color Lab	€ 1.226,00



## EL851101

Kg 13  
Box pcs 1



Miscelatore monocomando per vasca a pavimento con flessibile, doccia.

Single lever floor bath mixer with flexible hose, handshower.

Mitigeur baignoire au sol avec flexible, douche.

Einhebelmischer Stand-Badebatterie mit Brauseschlauch, Handbrause.

Monomando para bañera de suelo, con flexible y ducha de mano.

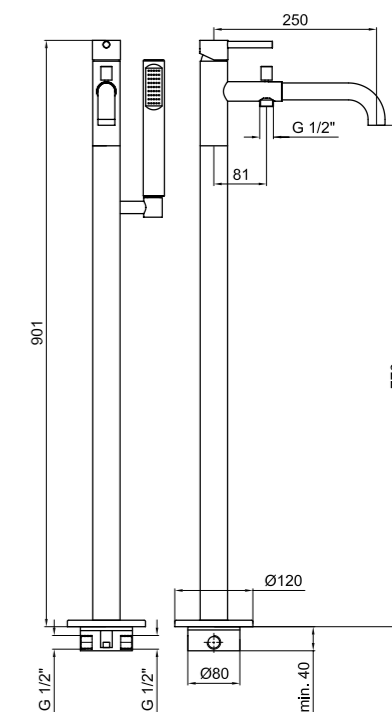

.015	Cromo / Chrome / Chromée / Verchromt / Cromado	€ 973,00
.560	Nero opaco / Matt black / Noir mat/ Matt Schwarz / Negro mate	€ 1.362,00
.345	Acciaio spazzolato / Brushed nickel / Acier brossé / Edelstahl Optik / Acero cepillado	€ 1.557,00
	Color Lab	€ 1.377,00

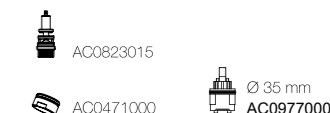

## EL850101

Kg 3,2  
Box pcs 6



Miscelatore monocomando per vasca esterno completo con flessibile in ottone da 150 cm doccia multifunzione anticalcare e supporto.

Single lever bath mixer with shower set complete of brass hose 150 cm, multifunction handshower and holder.

Mitigeur bain-douche complet de flexible 150 cm, douche multijet et support mural.

Einhebelmischer Badebatterie mit Brausegarnitur bestehend aus Metall-Brauseschlauch 150 cm, Massagehandbrause und Wandhalterung.

Monomando externo para bañera completo, con tubo flexible de latón de 150 cm, ducha masaje antical y soporte.

.015	Cromo / Chrome / Chromée / Verchromt / Cromado	€ 363,00
.560	Nero opaco / Matt black / Noir mat/ Matt Schwarz / Negro mate	€ 508,00
.345	Acciaio spazzolato / Brushed nickel / Acier brossé / Edelstahl Optik / Acero cepillado	€ 580,00
	Color Lab	€ 523,00

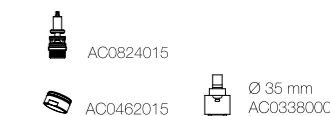
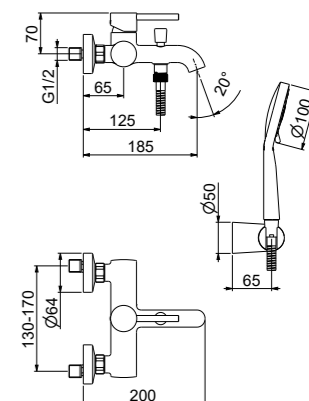

## EL850701

Kg 4,5  
Box pcs 6



Diametro foratura pannello vasca A-C = Ø28 mm  
Diametro foratura pannello vasca B-D = Ø53 mm /  
Diameter of the bath deck drilling A-C = Ø28 mm  
Diameter of the bath deck drilling B-D = Ø53 mm /  
Diamètre perçage du bord de la baignoire A-C = Ø 28 mm.  
Diamètre perçage du bord de la baignoire B-D = Ø 53 mm. /  
Bohrungsdurchmesser der Wannenrandarmatur A-C = Ø28 mm.  
Bohrungsdurchmesser der Wannenrandarmatur B-D = Ø53 mm. /  
Diámetro agujero borde de bañera A-C = Ø28 mm.  
Diámetro agujero borde de bañera B-D = Ø53 mm.

Gruppo per bordo vasca 4 fori completo con flessibile in ottone da 150 cm e doccetta.

4-holes deck mounted bath mixer complete of brass hose 150 cm and handshower.

Mélangeur bain-douche 4-trous, flexible 150 cm et douchette.

4-Loch-Wannenrandarmatur mit Metallbrauseschlauch 150 cm und Handbrause.

Grupo para borde de bañera, 4 agujeros, con tubo flexible de latón, flexibles 150 cm y ducha.

.015	Cromo / Chrome / Chromée / Verchromt / Cromado	€ 425,00
.560	Nero opaco / Matt black / Noir mat/ Matt Schwarz / Negro mate	€ 564,00
.345	Acciaio spazzolato / Brushed nickel / Acier brossé / Edelstahl Optik / Acero cepillado	€ 644,00
Color Lab		€ 579,00

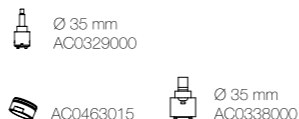
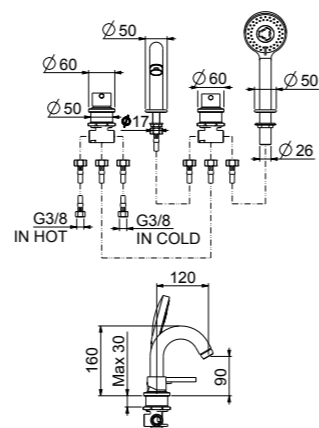

## EL880101

Kg 1,1  
Box pcs 12



PER FINITURE CONSULTARE  
SEZIONE EASY BATHROOM A PAG. 260

FOR ALL AVAILABLE FINISHINGS  
PLEASE GO TO EASY BATHROOM P. 260

Miscelatore monocomando per doccia incasso, con piastra, senza flessibile, doccetta e gancio.

Concealed single lever shower mixer with cover plate, without shower set.

Mitigeur de douche à encastrer avec rosace, sans garniture de douche.

Einhebelmischer Unterputz-Brausebatterie, mit Rosette, ohne Brausegarnitur.

Monomando empotrable para ducha, con placa, sin tubo flexible, ducha ni gancho.

.015 Cromo / Chrome / Chromée / Verchromt / Cromado € 122,00

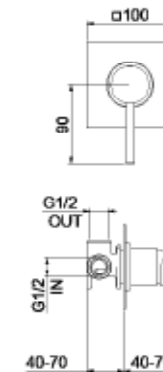

## EL860512

Kg 3,2  
Box pcs 12



Miscelatore monocomando per vasca incasso, con deviatore, piastra orizzontale; con flessibile doccetta e gancio di supporto.

Concealed single lever bath mixer with diverter, horizontal cover plate, with shower set.

Mitigeur bain-douche à encastrer avec inverseur, rosace horizontale, avec garniture de douche.

Einhebelmischer Unterputz-Badebatterie mit Umstellung, waagerechte Rosette, mit Brausegarnitur.

Monomando empotrable para bañera, con desviador, placa horizontal, con flexible, ducha ni gancho de soporte.

.015	Cromo / Chrome / Chromée / Verchromt / Cromado	€ 318,00
.560	Nero opaco / Matt black / Noir mat/ Matt Schwarz / Negro mate	€ 445,00
.345	Acciaio spazzolato / Brushed nickel / Acier brossé / Edelstahl Optik / Acero cepillado	€ 509,00
Color Lab		€ 460,00

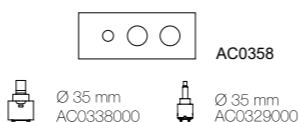
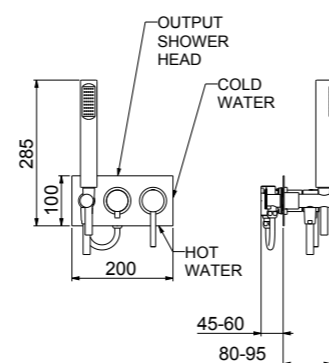

## EL880109

Kg 1,1  
Box pcs 12



PER FINITURE CONSULTARE  
SEZIONE EASY BATHROOM A PAG. 260

FOR ALL AVAILABLE FINISHINGS  
PLEASE GO TO EASY BATHROOM P. 260

Miscelatore monocomando per doccia incasso, con piastra, senza flessibile, doccetta e gancio.

Concealed single lever shower mixer with cover plate, without shower set.

Mitigeur de douche à encastrer avec inverseur, rosace horizontale, avec garniture de douche.

Einhebelmischer Unterputz-Brausebatterie, mit Rosette, ohne Brausegarnitur.

Monomando empotrable para ducha, con placa, sin tubo flexible, ducha ni gancho.

.015 Cromo / Chrome / Chromée / Verchromt / Cromado € 132,00

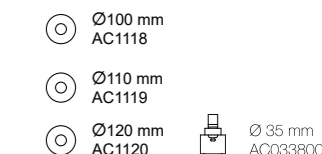
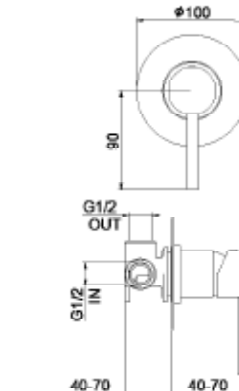

## AC0371

Kg 0,4  
Box pcs 12



Bocca d'erogazione senza deviatore per vasca incasso, attacco da 1/2".

Spout for concealed bath mixer, 1/2" connection.

Bec pour mitigeur bain/douche encastré, attache 1/2".

Gussauslauf für Unterputz-Badebatterie, 1/2" Anschluss.

Boca de erogación sin desviador para bañera empotrable; conexión 1/2".

.015	Cromo / Chrome / Chromée / Verchromt / Cromado	€ 80,00
.560	Nero opaco / Matt black / Noir mat/ Matt Schwarz / Negro mate	€ 112,00
.345	Acciaio spazzolato / Brushed nickel / Acier brossé / Edelstahl Optik / Acero cepillado	€ 128,00

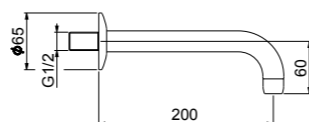

## EL860101

Kg 2,4  
Box pcs 12



PER FINITURE CONSULTARE  
SEZIONE EASY BATHROOM A PAG. 260

FOR ALL AVAILABLE FINISHINGS  
PLEASE GO TO EASY BATHROOM P. 260

Miscelatore monocomando per vasca incasso, con deviatore, piastra orizzontale, senza flessibile doccetta e gancio di supporto.

Concealed single lever bath mixer with diverter, horizontal cover plate, without shower set.

Mitigeur bain-douche à encastrer avec inverseur, rosace horizontale, sans garniture de douche.

Einhebelmischer Unterputz-Badebatterie mit Umstellung, waagerechte Rosette, ohne Brausegarnitur.

Monomando empotrable para bañera, con desviador, placa horizontal, sin tubo flexible, ducha ni gancho de soporte.

.015 Cromo / Chrome / Chromée / Verchromt / Cromado € 224,00

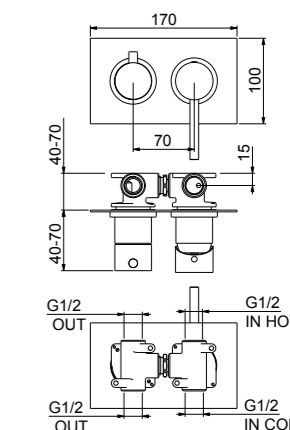

## AC1082

 Kg 1,1  
Box pcs 12



Deviatore incasso completo, 2 vie.  
Concealed 2 ways diverter.  
Inverseur 2 voies à encastré.  
Unterputz 2-Weg Umsteller.  
Desviador 2 vías empotrable.

.015 Cromo / Chrome / Chromée / Verchromt / Cromado € 112,00

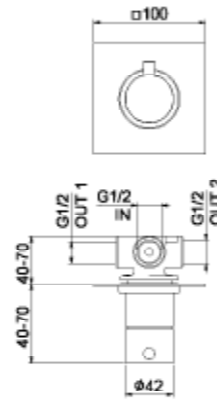

 AC0359015  Ø 35 mm  
AC0329000

## AC1083





 Kg 1,1  
Box pcs 12

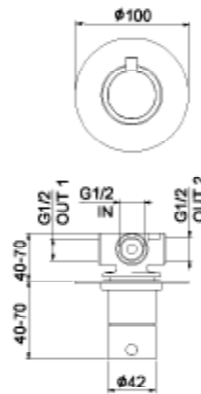

Deviatore incasso completo, 2 vie.  
Concealed 2 ways diverter.  
Inverseur 2 voies à encastré.  
Unterputz 2-Weg Umsteller.  
Desviador 2 vías empotrable.

.015 Cromo / Chrome / Chromée / Verchromt / Cromado € 122,00



 Ø100 mm  
AC1118  
 Ø110 mm  
AC1119  
 Ø120 mm  
AC1120  Ø 35 mm  
AC0329000

## EL980102

 Kg 3,2  
Box pcs 8



Miscelatore termostatico per doccia esterno, senza flessibile, doccetta e gancio di supporto.  
Thermostatic shower mixer without shower set.  
Mitigeur thermostatique douche sans garniture de douche.  
Thermostat Brausebatterie ohne Brausegarnitur.  
Mezclador termostatico externo para ducha, sin tubo flexible, rociador, ni soporte.

.015 Cromo / Chrome / Chromée / Verchromt / Cromado € 195,00  
.560 Nero opaco / Matt black / Noir mat/ Matt Schwarz / Negro mate € 273,00  
.345 Acciaio spazzolato / Brushed nickel / Acier brossé / Edelstahl Optik / Acero cepillado € 312,00  
Color Lab € 288,00

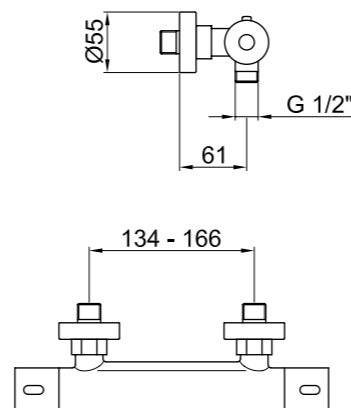

## EL980502

 Kg 3,2  
Box pcs 8



Miscelatore termostatico per doccia esterno con attacco colonna, senza flessibile, doccetta e gancio di supporto.  
Thermostatic shower mixer without shower set.  
Mitigeur thermostatique douche sans garniture de douche.  
Thermostat Brausebatterie ohne Brausegarnitur.

Mezclador termostatico externo para ducha, sin tubo flexible, rociador, ni soporte.

.015 Cromo / Chrome / Chromée / Verchromt / Cromado € 211,00  
.560 Nero opaco / Matt black / Noir mat/ Matt Schwarz / Negro mate € 275,00  
.345 Acciaio spazzolato / Brushed nickel / Acier brossé / Edelstahl Optik / Acero cepillado € 338,00  
Color Lab € 310,00

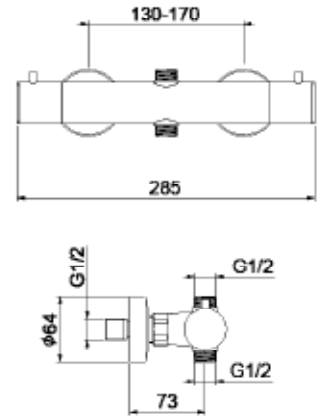

## EL870102

 Kg 2,2  
Box pcs 12



Miscelatore monocomando per doccia esterno; senza flessibile, doccetta e gancio di supporto.

Single lever shower mixer without shower set.

Mitigeur de douche sans garniture de douche.

Einhebelmischer Brausebatterie ohne Brausegarnitur.

Monomando externo para ducha, sin tubo flexible, ducha ni gancho de soporte.

.015 Cromo / Chrome / Chromée / Verchromt / Cromado € 190,00  
.560 Nero opaco / Matt black / Noir mat/ Matt Schwarz / Negro mate € 266,00  
.345 Acciaio spazzolato / Brushed nickel / Acier brossé / Edelstahl Optik / Acero cepillado € 304,00  
Color Lab € 281,00

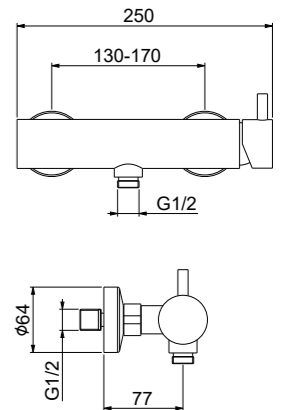

 Ø 35 mm  
AC0338000

## EL971302

 Kg 6  
Box pcs 2

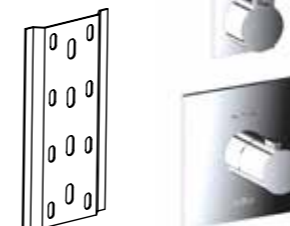

Termostatico incasso a parete alte portate con 1 via.

Thermostatic concealed high flow-rate mixer with 1 way diverter.

Mitigeur thermostatique haut-débit à encastrer avec 1 voies.

Thermostat Unterputz HD Mischer mit 1 Wegeumsteller.

Termostático empotrable alto caudal 1 vía.

.015 Cromo / Chrome / Chromée / Verchromt / Cromado € 745,00  
.560 Nero opaco / Matt black / Noir mat/ Matt Schwarz / Negro mate € 1.043,00  
.345 Acciaio spazzolato / Brushed nickel / Acier brossé / Edelstahl Optik / Acero cepillado € 1.192,00  
Color Lab € 1.058,00

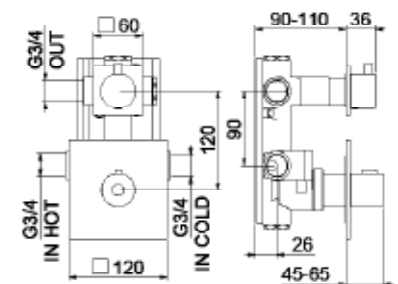

 AC0855  AC0864  
 AC0861  AC0996

## EL971402

 Kg 6,5  
Box pcs 2

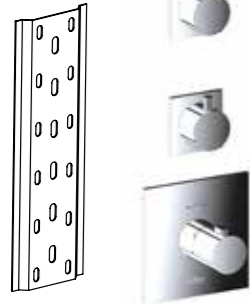

Termostatico incasso a parete alte portate con 2 vie.

Thermostatic concealed high flow-rate mixer with 2 ways diverter.

Mitigeur thermostatique haut-débit à encastrer avec 2 voies.

Thermostat Unterputz HD Mischer mit 2 Wegeumsteller.

Termostático empotrable alto caudal 2 vías.

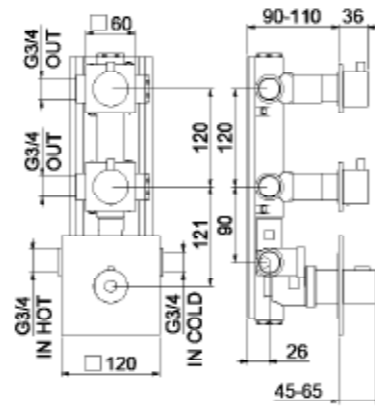

- .015 Cromo / Chrome / Chromée / Verchromt / Cromado € 895,00
- .560 Nero opaco / Matt black / Noir mat/ Matt Schwarz / Negro mate € 1.253,00
- .345 Acciaio spazzolato / Brushed nickel / Acier brossé / Edelstahl Optik / Acero cepillado € 1.432,00
- Color Lab € 1.268,00



## EL971502

 Kg 2  
Box pcs 7

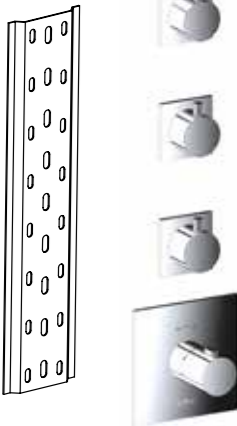

Termostatico incasso a parete alte portate con 3 vie.

Thermostatic concealed high flow-rate mixer with 3 ways diverter.

Mitigeur thermostatique haut-débit à encastrer avec 3 voies.

Thermostat Unterputz HD Mischer mit 3 Wegeumsteller.

Termostático empotrable alto caudal 3 vías.

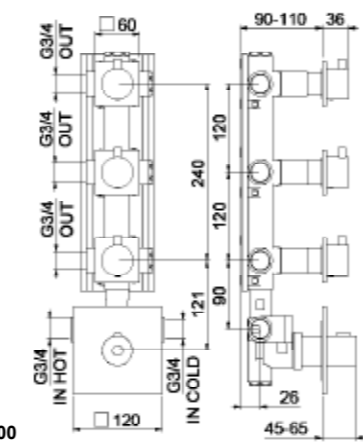

- .015 Cromo / Chrome / Chromée / Verchromt / Cromado € 1.030,00
- .560 Nero opaco / Matt black / Noir mat/ Matt Schwarz / Negro mate € 1.442,00
- .345 Acciaio spazzolato / Brushed nickel / Acier brossé / Edelstahl Optik / Acero cepillado € 1.648,00
- Color Lab € 1.457,00



## EL870303

 Kg 12  
Box pcs 1,8



Miscelatore monocomando a parete con doccetta igienica PVC a pulsante.

Single lever mixer with hygienic shower PVC with trigger.

Mitigeur mural avec douchette hygiénique PVC à bouton.

EH Wandmischer mit PVC Hygiene Handbrause.

Mezclador de pared con ducha higiénica PVC.

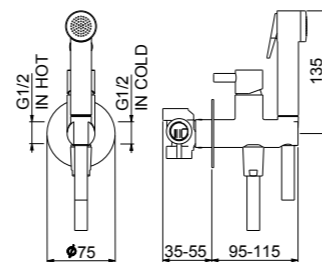

- .015 Cromo / Chrome / Chromée / Verchromt / Cromado € 200,00
- .560 Nero opaco / Matt black / Noir mat/ Matt Schwarz / Negro mate € 280,00
- .345 Acciaio spazzolato / Brushed nickel / Acier brossé / Edelstahl Optik / Acero cepillado € 320,00



## EL870301

 Kg 12  
Box pcs 1,8



Miscelatore monocomando a parete con doccetta igienica METAL a pulsante.

Single lever mixer with hygienic shower METAL with trigger.

Mitigeur mural avec douchette hygiénique en laiton à bouton.

EH Wandmischer mit aus Messing Hygiene Handbrause.

Mezclador de pared con ducha higiénica de METAL.

- .015 Cromo / Chrome / Chromée / Verchromt / Cromado € 213,00
- .560 Nero opaco / Matt black / Noir mat/ Matt Schwarz / Negro mate € 255,00
- .345 Acciaio spazzolato / Brushed nickel / Acier brossé / Edelstahl Optik / Acero cepillado € 340,00
- .010 Oro / Gold / Doré / Gold / Oro € 298,00
- .065 Bronzato / Bronze / Bronze / Bronze / Bronze € 266,00
- Collezione Primavera € 340,00

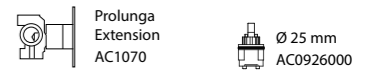
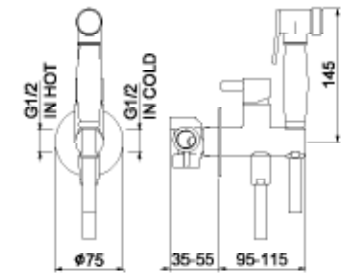

## EL870302

 Kg 12  
Box pcs 1,8



Miscelatore monocomando a parete con doccetta igienica METAL a pulsante.

Single lever mixer with hygienic shower METAL with trigger.

Mitigeur mural avec douchette hygiénique en laiton à bouton.

EH Wandmischer mit aus Messing Hygiene Handbrause.

Mezclador de pared con ducha higiénica de METAL.

- .015 Cromo / Chrome / Chromée / Verchromt / Cromado € 226,00
- .345 Acciaio spazzolato / Brushed nickel / Acier brossé / Edelstahl Optik / Acero cepillado € 360,00
- .010 Oro / Gold / Doré / Gold / Oro € 293,00
- .065 Bronzato / Bronze / Bronze / Bronze / Bronze € 283,00

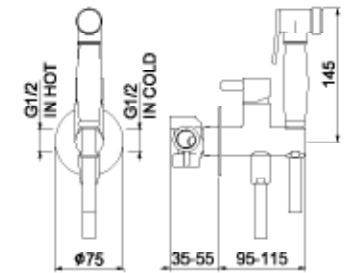

# AZETA NEW



AA830401.015  
Miscelatore lavabo alto.  
One hole high basin mixer.

Finiture / finishes / finitions / ausführungen / acabados

.015  
Cromo  
Chrome  
Chromé  
Verchromt  
Cromado



AZ870110.015  
Colonna doccia.  
Shower column.



## AA830101

 Kg 2  
Box pcs 12



Miscelatore monocomando per lavabo con scarico 1"1/4 con flex inox cm 50 att. 3/8" F.

Single lever washbasin mixer with 1"1/4 pop-up waste and 3/8" F flex. hoses cm 50.

Mitigeur de lavabo avec vidage automatique 1"1/4 et flexibles d'alimentation cm 50 3/8" F.

Einhebelmischer Waschtischbatterie mit Ablaufgarnitur 1" 1/4 und flex. Anschlussschläuchen cm 50 3/8" F.

Monomando para lavabo con desagüe 1" 1/4, tubo flexible inoxidable de 50 cm, empalme 3/8" F.

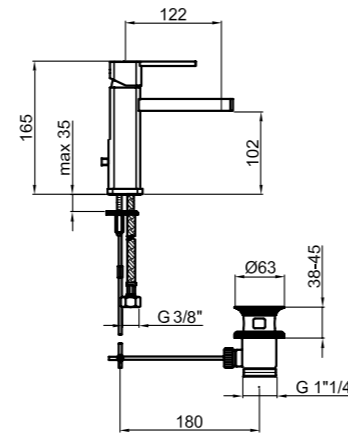

 AA830102

.015 Cromo / Chrome / Chromée / Verchromt / Cromado € 244,00

 AC0470015  Ø 25 mm AC0355000

## AA830401

 Kg 3,2  
Box pcs 4



Miscelatore monocomando per lavabo alto con scarico up & down, flex inox cm 70 att. 3/8" F.

High single lever washbasin mixer with up & down pop-up waste, with 3/8" flex. hoses 70 cm.

Mitigeur de lavabo haut avec vidage up & down, flexibles d'alimentation cm 70 3/8" F.

Einhebelmischer Waschtischbatterie, mit Ausführung, mit up & down Ablaufgarnitur, mit Flex. Anschlussschläuchen cm 70 3/8" F.

Monomando para lavabo alto con valvula click-clack, tubo flexible inoxidable de 70 cm, empalme 3/8" F.

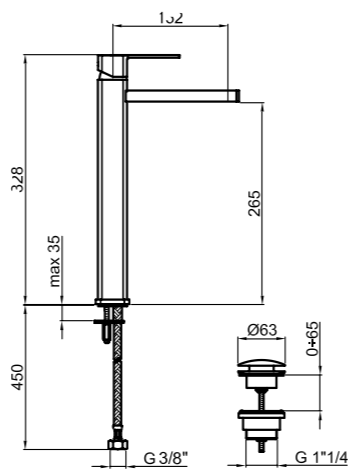

 AA830402

.015 Cromo / Chrome / Chromée / Verchromt / Cromado € 348,00

 AC0470015  Ø 25 mm AC0355000

## AA830606

 Kg 2,4  
Box pcs 12



Miscelatore monocomando per lavabo incasso muro, con piastra orizzontale, senza scarico e flessibili.

Concealed single lever washbasin mixer, horizontal cover plate, without pop-up waste and flex hoses.

Mitigeur de lavabo à encastrer, rosace horizontale, sans vidage et flexibles.

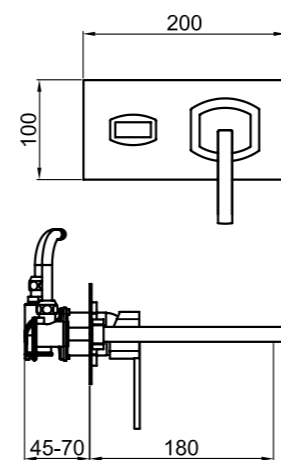

Einhebelmischer Unterputz-Waschtischbatterie waagerechte Rosette, ohne Ablaufgarnitur und flex. Anschlussschläuchen.

Monomando empotrable para lavabo de pared, con placa horizontal, sin desagüe ni tubos flexibles.



 AC0356015

.015 Cromo / Chrome / Chromée / Verchromt / Cromado € 335,00

 AC0470015  Ø 35 mm AC0338000

## AA840101

 Kg 1,8  
Box pcs 12



Miscelatore monocomando per bidet con scarico 1"1/4 con flex inox cm 50 att. 3/8" F.

Single lever bidet mixer with 1"1/4 pop-up waste and 3/8" F flex. hoses cm 50 .

Mitigeur de bidet avec vidage automatique 1"1/4 et flexibles d'alimentation cm 50 3/8" F.

Einhebelmischer Bidetbatterie mit Ablaufgarnitur 1" 1/4 und flex. Anschlussschläuchen cm 50 3/8" F.

Monomando para bidé con desagüe 1" 1/4, tubo flexible inoxidable de 50 cm, empalme 3/8" F.

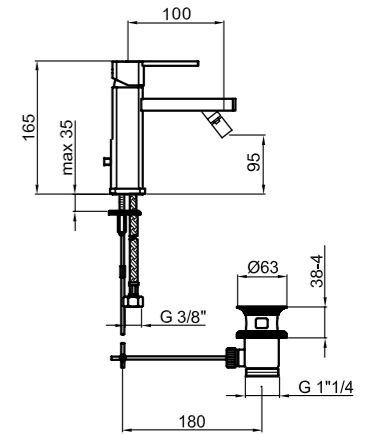

 AA840102

.015 Cromo / Chrome / Chromée / Verchromt / Cromado € 244,00

 AC0467015  Ø 25 mm AC0355000

## AA880101

 Kg 1,4  
Box pcs 12



Miscelatore monocomando per doccia incasso, con piastra, senza flessibile, doccetta e gancho.

Concealed single lever shower mixer with cover plate, without shower set.

Mitigeur de douche à encastrer avec rosace, sans garniture de douche.

Einhebelmischer Unterputz-Brausebatterie, mit Rosette ohne Brausegarnitur.

Monomando empotrable para ducha, con placa, sin tubo flexible, ducha ni gancho.

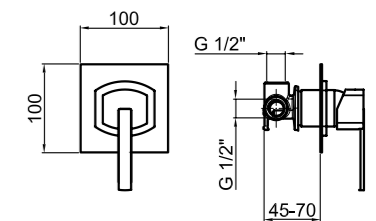

.015 Cromo / Chrome / Chromée / Verchromt / Cromado € 141,00

 AC03590015  Ø 35 mm AC0338000

## AA860101

 Kg 2,3  
Box pcs 12



Miscelatore monocomando per vasca incasso, con deviatore, piastra, senza flessibile doccetta e gancho di supporto.

Concealed single lever bath mixer with diverter, cover plate, without shower set.



Mitigeur bain-douche à encastrer avec inverseur, rosace, sans garniture de douche.

Einhebelmischer Unterputz-Badebatterie mit Umstellung, Rosette, ohne Brausegarnitur.

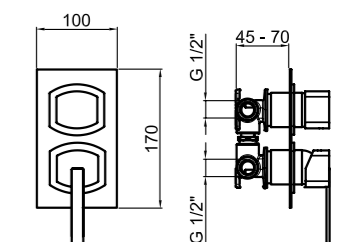
Monomando empotrable para bañera, con desviador, placa, sin tubo flexible, ducha ni gancho de soporte.



.015 Cromo / Chrome / Chromée / Verchromt / Cromado € 273,00

 AC0357015  Ø 35 mm AC0338000



# PEGASO



CREATIVITY



PE830101.335  
Miscelatore lavabo.  
One hole basin mixer.

— MET.  
*Celestite*



# Accessori

BAGNO & DOCCIA



**ACC601.365**  
Appendino.  
Hook.



**ACC011.365**  
Porta sapone.  
Soap holder.



**ACC211.365**  
Dispenser sapone liquido.  
Liquid soap dispenser.



**ACC400.365**  
Porta salvietta.  
Towel rail.

**PE870605.365**  
Miscelatore per doccia esterno con deviatore  
incorporato, colonna, soffione e doccia.  
Shower mixer with integrated diverter,  
column, shower head and handshower.

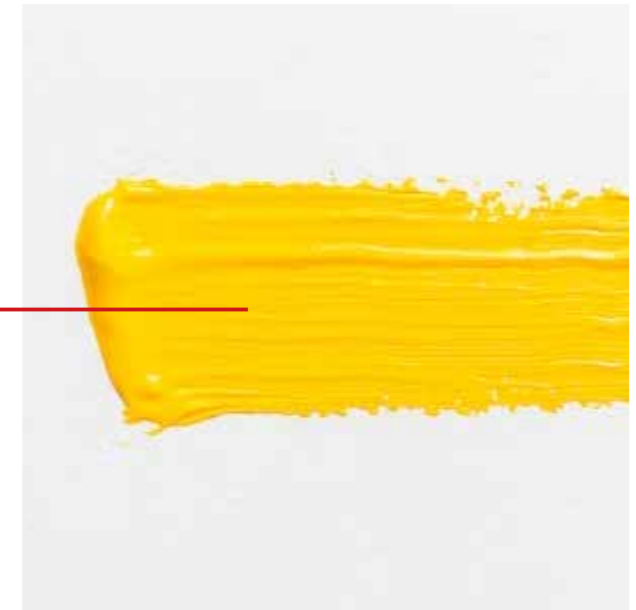
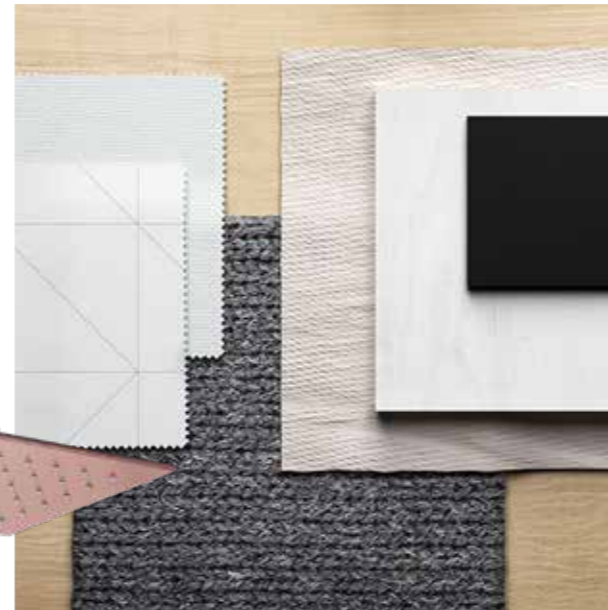

— MET. —

# Perla rosa





PE830401.365  
Miscelatore lavabo alto.  
One hole basin mixer, high body.

## PE830101

Kg 1,8  
Box pcs 10



Miscelatore monocomando per lavabo con scarico up & down con flex inox cm 50 att. 3/8" F.

Single lever washbasin mixer with 1"1/4 pop-up waste, with 3/8" F flex. hoses cm 50.

Mitigeur de lavabo avec vidage automatique 1"1/4 et flexibles d'alimentation cm 50 3/8" F.

Einhebelmischer Waschtischbatterie mit Ablaufgarnitur 1"1/4 und flex. Anschlussschläuchen cm 50 3/8" F.

Monomando para lavabo con desagüe 1"1/4, tubo flexible inoxidable de 50 cm, empalme 3/8" F.

.015	Cromo / Chrome / Chromée / Verchromt / Cromado	€ 165,00
.560	Nero opaco / Matt black / Noir mat / Matt Schwarz / Negro mate	€ 198,00
.740	Bianco opaco / Matt white / Blanc mat / Matt Glanzend / Blanco mate	€ 198,00
	Color Lab	€ 213,00
	Collezione Primavera	€ 280,00

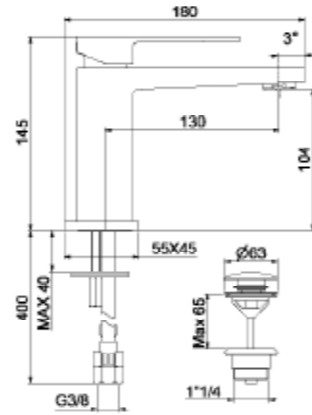

AC1110

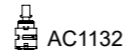

PE830102

## PE833101

Kg 2,7  
Box pcs 5



Miscelatore monocomando per lavabo con scarico up & down con flex inox cm 50 att. 3/8" F.

Single lever washbasin mixer with 1"1/4 pop-up waste, with 3/8" F flex. hoses cm 50.

Mitigeur de lavabo avec vidage automatique 1"1/4 et flexibles d'alimentation cm 50 3/8" F.

Einhebelmischer Waschtischbatterie mit Ablaufgarnitur 1"1/4 und flex. Anschlussschläuchen cm 50 3/8" F.

Monomando para lavabo con desagüe 1"1/4, tubo flexible inoxidable de 50 cm, empalme 3/8" F.

.015	Cromo / Chrome / Chromée / Verchromt / Cromado	€ 171,00
.560	Nero opaco / Matt black / Noir mat / Matt Schwarz / Negro mate	€ 205,00
.740	Bianco opaco / Matt white / Blanc mat / Matt Glanzend / Blanco mate	€ 205,00
	Color Lab	€ 220,00
	Collezione Primavera	€ 280,00

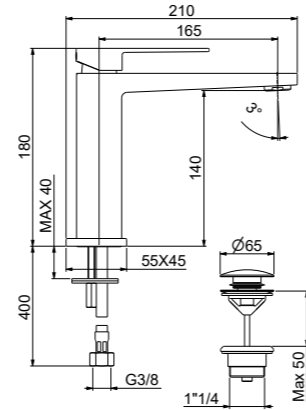

AC1110



PE833102

## PE830401

Kg 2,7  
Box pcs 5



Miscelatore monocomando per lavabo alto con scarico up & down, flex inox cm 70 att. 3/8" F.

High single lever washbasin mixer with up & down pop-up waste, with 3/8" flex. hoses 70 cm.

Mitigeur de lavabo haut avec vidage up & down, flexibles d'alimentation cm 70 3/8" F.

Einhebelmischer Waschtischbatterie, mit Ausführung, mit up & down Ablaufgarnitur, mit Flex. Anschlussschläuchen cm 70 3/8" F.

Monomando para lavabo alto con valvula click-clack, tubo flexible inoxidable de 70 cm, empalme 3/8" F.

.015	Cromo / Chrome / Chromée / Verchromt / Cromado	€ 255,00
.560	Nero opaco / Matt black / Noir mat / Matt Schwarz / Negro mate	€ 306,00
.740	Bianco opaco / Matt white / Blanc mat / Matt Glanzend / Blanco mate	€ 306,00
	Color Lab	€ 321,00
	Collezione Primavera	€ 433,00

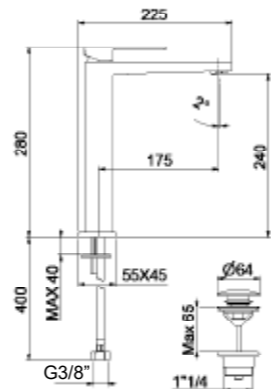

AC1110



PE830402

## PE838606

Kg 1,3  
Box pcs 10



PER FINITURE CONSULTARE  
SEZIONE EASY BATHROOM A PAG. 260

FOR ALL AVAILABLE FINISHINGS  
PLEASE GO TO EASY BATHROOM P. 260

Miscelatore monocomando per lavabo incasso muro, con piastra, senza scarico e flessibili.

Concealed single lever washbasin mixer, cover plate, without pop-up waste and flex hoses.

Mitigeur de lavabo à encastrer, rosace, sans vidage et flexibles.

Einhebelmischer Unterputz-Waschtischbatterie, Rosette, ohne Ablaufgarnitur und flex. Anschlussschläuchen.

Monomando empotrable para lavabo de pared, con placa, sin desagüe ni tubos flexibles.

.015 Cromo / Chrome / Chromée / Verchromt / Cromado € 167,00

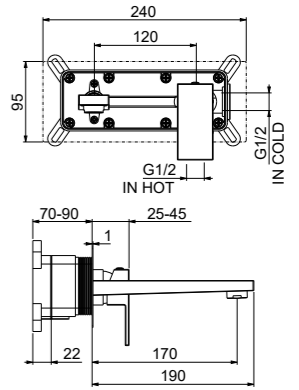

AC1110

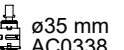

## PE840101

Kg 1,65  
Box pcs 10



Miscelatore monocomando per bidet con scarico up & down, con flex inox cm 50 att. 3/8" F.

Single lever bidet mixer with up & down pop-up waste, with 3/8" F flex. hoses cm 50.

Mitigeur de bidet avec vidage up & down, flexibles d'alimentation cm 50 3/8" F.

Einhebelmischer Bidetbatterie mit up & down Ablaufgarnitur 1" 1/4, mit flex. Anschlussschläuchen cm 50 3/8" F.

Monomando para bidé con desagüe up & down, tubo flexible inoxidable de 50 cm, empalme 3/8" F.

.015	Cromo / Chrome / Chromée / Verchromt / Cromado	€ 150,00
.560	Nero opaco / Matt black / Noir mat / Matt Schwarz / Negro mate	€ 180,00
.740	Bianco opaco / Matt white / Blanc mat / Matt Glanzend / Blanco mate	€ 180,00
	Color Lab	€ 195,00
	Collezione Primavera	€ 255,00

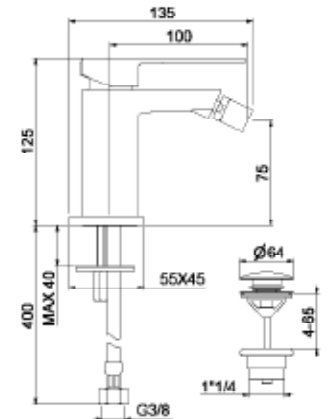

AC1133



PE840102

## PE850101

Kg 2,5  
Box pcs 12



Miscelatore monocomando per vasca esterno completo con flessibile in ottone da 150 cm doccia anticalcare e supporto.

Single lever bath mixer with shower set complete of brass hose 150 cm, handshower and holder.

Mitigeur bain-douche complet de flexible 150 cm, douchette et support mural.

Einhebelmischer Badebatterie mit Brausegarnitur bestehend aus Metall-Brauseschlauch 150 cm, Handbrause und Wandhalterung.

Monomando externo para bañera completo, con tubo flexible de latón de 150 cm, ducha antical y soporte.

.015	Cromo / Chrome / Chromée / Verchromt / Cromado	€ 238,00
.560	Nero opaco / Matt black / Noir mat / Matt Schwarz / Negro mate	€ 333,00
.740	Bianco opaco / Matt white / Blanc mat / Matt Glanzend / Blanco mate	€ 333,00
	Color Lab	€ 348,00
	Collezione Primavera	€ 428,00

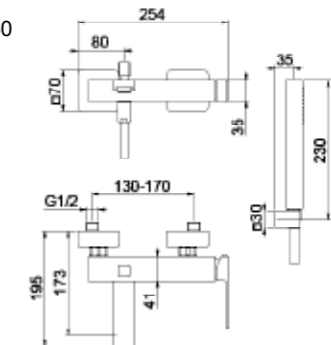

AC1135

AC1133

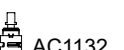

153 + € 15,00

## PE870102

 Kg 1,8  
Box pcs 10



Miscelatore monocomando per doccia esterno, senza flessibile, doccetta e gancio di supporto.

Single lever shower mixer without shower set.

Mitigeur de douche sans garniture de douche.

Einhebelmischer Brausebatterie ohne Brausegarnitur.

Monomando esterno para ducha, sin tubo flexible, ducha ni gancho de soporte.

.015	Cromo / Chrome / Chromée / Verchromt / Cromado	€ 150,00
.560	Nero opaco / Matt black / Noir mat / Matt Schwarz / Negro mate	€ 180,00
.740	Bianco opaco / Matt white / Blanc mat / Matt Glanzend / Blanco mate	€ 180,00
	Color Lab	€ 195,00
	Collezione Primavera	€ 255,00

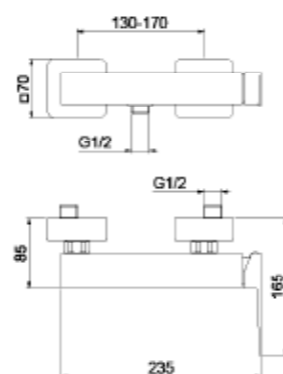

AC1132

 + € 15,00

## PE888101

 0,9 Kg  
Box pcs 20



Miscelatore monocomando per doccia incasso, con piastra, senza flessibile, doccetta e gancio.

Concealed single lever shower mixer with cover plate, without shower set.

Mitigeur de douche à encastrer avec rosace, sans garniture de douche.

Einhebelmischer Unterputz-Brausebatterie, mit Rosette ohne Brausegarnitur.

Monomando empotrable para ducha, con placa, sin tubo flexible, ducha ni gancho.

.015	Cromo / Chrome / Chromée / Verchromt / Cromado	€ 64,00
------	--	---------

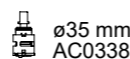
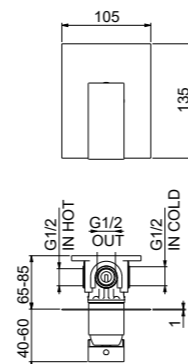

ø35 mm  
AC0338

PER FINITURE CONSULTARE  
SEZIONE EASY BATHROOM A PAG. 260

FOR ALL AVAILABLE FINISHINGS  
PLEASE GO TO EASY BATHROOM P. 260

## PE868101

 Kg 1,6  
Box pcs 20



Miscelatore monocomando per vasca incasso, con deviatore automatico e piastra, senza flessibile, doccetta e gancio di supporto.

Concealed single lever bath mixer with automatic diverter, cover plate, without shower set.

Mitigeur bain-douche à encastrer avec inverseur automatique, rosace, sans garniture de douche.

Einhebelmischer Unterputz-Badebatterie mit Umstellung, Rosette, ohne Brausegarnitur.

Monomando empotrable para bañera, con desviador automático, placa, sin tubo flexible, ducha ni gancho de soporte.

.015	Cromo / Chrome / Chromée / Verchromt / Cromado	€ 112,00
.560	Nero opaco / Matt black / Noir mat / Matt Schwarz / Negro mate	€ 157,00

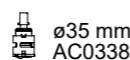
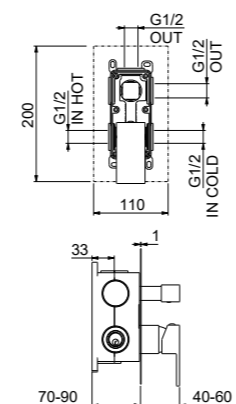

ø35 mm  
AC0338

## PE888601

 Kg 1,9  
Box pcs 20



Miscelatore monocomando per doccia incasso, con deviatore 3 vie.

Concealed single lever shower mixer, with 3-ways diverter.

Mitigeur de douche encastré avec inverseur 3 voies.

Einhebelmischer Unterputz-Brausebatterie mit 3 Wegeumsteller.

Monomando empotrable para ducha, con desviador 3 vias.

PER FINITURE CONSULTARE  
SEZIONE EASY BATHROOM A PAG. 260

FOR ALL AVAILABLE FINISHINGS  
PLEASE GO TO EASY BATHROOM P. 260

.015	Cromo / Chrome / Chromée / Verchromt / Cromado	€ 191,00
------	--	----------

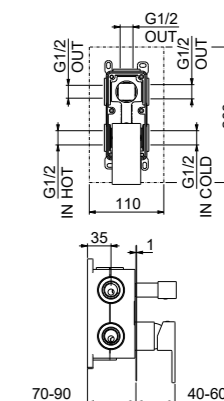

## AC1077



Bocca d'erogazione senza deviatore per lavabo incasso, attacco da 1/2".

Spout for concealed basin mixer, 1/2" connection.

Bec pour mitigeur lavabo encastré, attache 1/2".

Gussauslauf für Unterputz-Waschtischbatterie, 1/2" Anschluss.

Boca de erogación sin desviador para lavabo empotrable; conexión 1/2".

.015	Cromo / Chrome / Chromée / Verchromt	€ 135,00
.560	Nero opaco / Matt black / Noir mat / Matt Schwarz	€ 189,00
.740	Bianco opaco / Matt white / Blanc mat / Matt Weiss	€ 189,00
	Collezione Primavera	€ 243,00

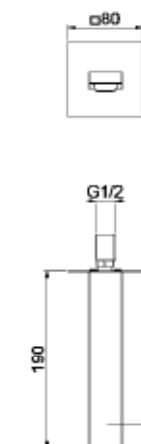

AC1110



# DO RE MI

Design: Massimiliano Settimelli



DR830606.248  
Miscelatore lavabo a muro.  
Wall basin mixer.





Finiture / finishes / finitions / ausföhrungen / acabados

.015  
Cromo  
Chrome  
Chromé  
Verchromt  
Cromado

.560  
Nero opaco  
Matt black  
Noir mat  
Matt Schwarz  
Negro mate

.345  
Acciaio spazzolato  
Brushed nickel  
Acier brossé  
Edelstahl Optik  
Acero cepillado

Color Lab

Collezione  
Primavera



Do Re Mi ha linee semplici e originali. Il suo design, nato dalla matita di Massimiliano Settimelli, trova ispirazione nelle forme di una partitura musicale, nel segno semplice e inequivocabile di una nota. È una collezione che gioca con gli elementi per creare una perfetta armonia d'insieme, e dare vita a un suono: quello che solo lo scorrere dell'acqua può trasmettere.

Do Re Mi has got simple and original lines. Its design, created from the pencil of Massimiliano Settimelli, draws inspiration from the lines of a music score, from a simple and unambiguous musical note. This collection plays with the elements in order to create a perfect harmony and to give life to a sound: the sound that only water flow can convey.





DR830101.325  
Miscelatore lavabo.  
One hole basin mixer.



DR830101.015  
Miscelatore lavabo.  
One hole basin mixer.



KIT DOCCETTA / SHOWER KIT  
ART. AC0982.355

BRACCIO DOCCIA CON SOFFIONE /  
SHOWER ARM WITH SHOWER HEAD  
ART. AC0398.355



\_\_\_\_\_ MET.  
*Nickel*

PRACTICALITY



DO RE MI

LAVABO / BASIN MIXER  
ART. DR830101.355



COMPRO -  
MISES

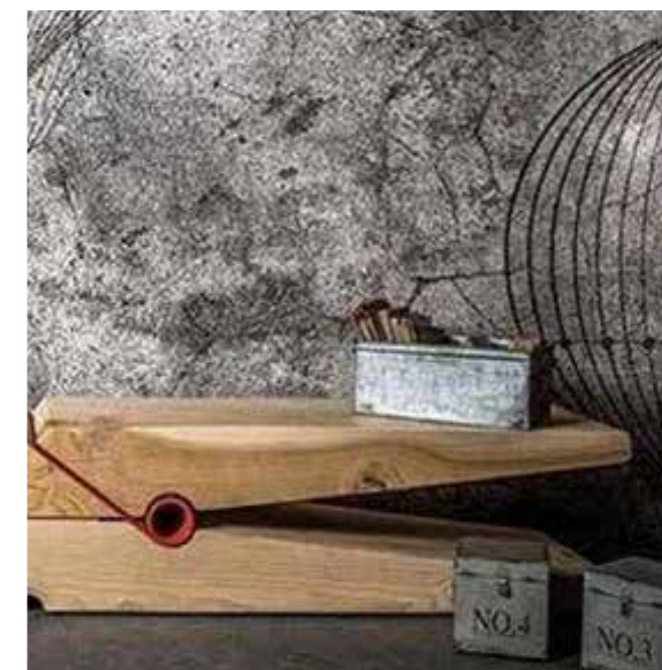

## DR830101

Kg 2,1  
Box pcs 12



Miscelatore monocomando per lavabo con scarico 1"1/4 con flex inox cm 50 att. 3/8" F.

Single lever washbasin mixer with 1"1/4 pop-up waste and 3/8" F flex. hoses cm 50.

Mitigeur de lavabo avec vidage automatique 1"1/4 et flexibles d'alimentation cm 50 3/8" F.

Einhebelmischer Waschtischbatterie mit Ablaufgarnitur 1" 1/4 und flex. Anschlussschläuchen cm 50 3/8" F.

Monomando para lavabo con desagüe 1" 1/4, tubo flexible inoxidable de 50 cm, empalme 3/8" F.

.015 Cromo / Chrome / Chromée / Verchromt / Cromado € 170,00

.560 Nero opaco / Matt black / Noir mat / Matt Schwarz / Negro mate € 238,00

.345 Acciaio spazzolato / Brushed nickel Acier brossé / Edelstahl Optik / Acero cepillado € 272,00

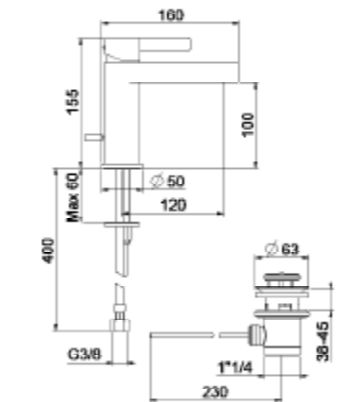

AC0988000 Ø 35 mm AC0977000

DR830102

## DR830201

Kg 2,1  
Box pcs 12



Miscelatore monocomando per lavabo con scarico up & down con flex inox cm 50 att. 3/8" F.

Single lever washbasin mixer with up & down pop-up waste and 3/8" F flex. hoses cm 50.

Mitigeur de lavabo avec vidage up & down et flexibles d'alimentation cm 50 3/8" F.

Einhebelmischer Waschtischbatterie mit up & down Ablaufgarnitur und flex. Anschlussschläuchen cm 50 3/8" F.

Monomando para lavabo con valvula click clack, tubo flexible inoxidable de 50 cm, empalme 3/8" F.

.015 Cromo / Chrome / Chromée / Verchromt / Cromado € 199,00

.560 Nero opaco / Matt black / Noir mat / Matt Schwarz / Negro mate € 279,00

.345 Acciaio spazzolato / Brushed nickel Acier brossé / Edelstahl Optik / Acero cepillado € 318,00

Color Lab € 294,00

Collezione Primavera € 318,00

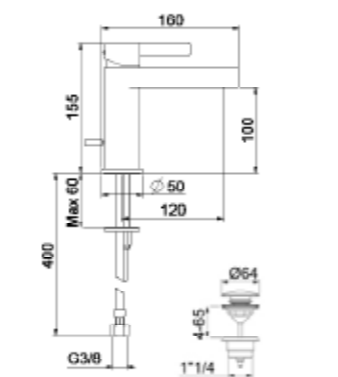

AC0988000 Ø 35 mm AC0977000

DR830202

## DR830401

Kg 2,7  
Box pcs 10



Miscelatore monocomando per lavabo alto con scarico up & down, flex inox cm 70 att. 3/8" F.

High single lever washbasin mixer with up & down pop-up waste, with 3/8" flex. hoses 70 cm.

Mitigeur de lavabo haut avec vidage up & down, flexibles d'alimentation cm 70 3/8" F.

Einhebelmischer Waschtischbatterie, mit Ausführung, mit up & down Ablaufgarnitur, mit Flex. Anschlussschläuchen cm 70 3/8" F.

Monomando para lavabo alto con valvula click-clack, tubo flexible inoxidable de 70 cm, empalme 3/8" F.

.015 Cromo / Chrome / Chromée / Verchromt / Cromado € 235,00

.560 Nero opaco / Matt black / Noir mat / Matt Schwarz / Negro mate € 329,00

.345 Acciaio spazzolato / Brushed nickel Acier brossé / Edelstahl Optik / Acero cepillado € 376,00

Color Lab € 344,00

Collezione Primavera € 376,00

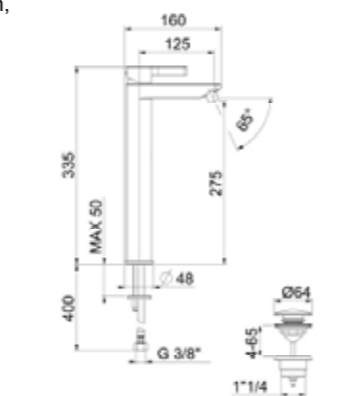

AC0990000 Ø 35 mm AC0977000

DR830402

## DR830606

Kg 2,1  
Box pcs 12



Miscelatore monocomando per lavabo incasso muro, con piastra orizzontale, senza scarico e flessibili.

Concealed single lever washbasin mixer, horizontal cover plate, without pop-up waste and flex hoses.

Mitigeur de lavabo à encastrer, rosace horizontale, sans vidage et flexibles.

Einhebelmischer Unterputz-Waschtischbatterie waagerechte Rosette, ohne Ablaufgarnitur und flex. Anschlussschläuchen.

Monomando empotrable para lavabo de pared, con placa horizontal, sin desagüe ni tubos flexibles.

.015 Cromo / Chrome / Chromée / Verchromt / Cromado € 195,00

PER FINITURE CONSULTARE SEZIONE EASY BATHROOM A PAG. 260

FOR ALL AVAILABLE FINISHINGS PLEASE GO TO EASY BATHROOM P. 260

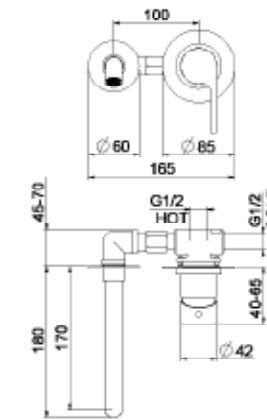

AC0979015 AC0980015

AC0469015 Ø 35 mm AC038000

## DR840101

Kg 2,1  
Box pcs 12



Miscelatore monocomando per bidet con scarico 1"1/4 con flex inox cm 50 att. 3/8" F.

Single lever bidet mixer with 1"1/4 pop-up waste and 3/8" F flex. hoses cm 50 .

Mitigeur de bidet avec vidage automatique 1"1/4 et flexibles d'alimentation cm 50 3/8" F.

Einhebelmischer Bidetbatterie mit Ablaufgarnitur 1" 1/4 und flex. Anschlussschläuchen cm 50 3/8" F.

Monomando para bidé con desagüe 1" 1/4, tubo flexible inoxidable de 50 cm, empalme 3/8" F.

.015 Cromo / Chrome / Chromée / Verchromt / Cromado € 170,00

.560 Nero opaco / Matt black / Noir mat / Matt Schwarz / Negro mate € 238,00

.345 Acciaio spazzolato / Brushed nickel Acier brossé / Edelstahl Optik / Acero cepillado € 272,00

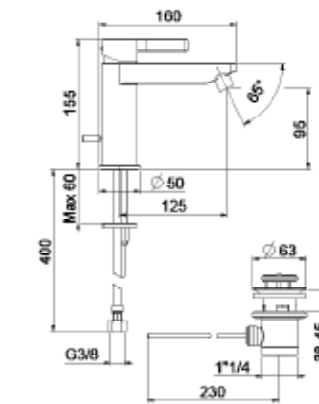

DR840102

## DR840201

Kg 2,1  
Box pcs 12



Miscelatore monocomando per bidet con scarico up & down con flex inox cm 50 att. 3/8" F.

Single lever bidet mixer with up & down pop-up waste and 3/8" F flex. hoses cm 50 .

Mitigeur de bidet avec vidage up & down et flexibles d'alimentation cm 50 3/8" F.

Einhebelmischer Bidetbatterie mit up & down Ablaufgarnitur und flex. Anschlussschläuchen cm 50 3/8" F.

Monomando para bidé con desagüe 1" 1/4, tubo flexible inoxidable de 50 cm, empalme 3/8" F.

.015 Cromo / Chrome / Chromée / Verchromt / Cromado € 199,00

.560 Nero opaco / Matt black / Noir mat / Matt Schwarz / Negro mate € 279,00

.345 Acciaio spazzolato / Brushed nickel Acier brossé / Edelstahl Optik / Acero cepillado € 318,00

Color Lab € 294,00

Collezione Primavera € 318,00

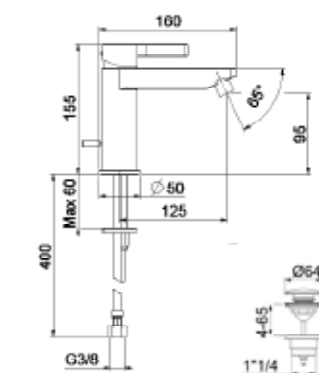

AC0990000 Ø 35 mm AC0977000

## DR880101

Kg 1,6  
Box pcs 12



PER FINITURE CONSULTARE  
SEZIONE EASY BATHROOM A PAG. 260

FOR ALL AVAILABLE FINISHINGS  
PLEASE GO TO EASY BATHROOM P. 260

Miscelatore monocomando per doccia incasso, con piastra, senza flessibile, doccetta e gancio.

Concealed single lever shower mixer with cover plate, without shower set.

Mitigeur de douche à encastrer avec rosace, sans garniture de douche.

Einhebelmischer Unterputz-Brausebatterie, mit Rosette ohne Brausegarnitur.

Monomando empotrable para ducha, con placa, sin tubo flexible, ducha ni gancho.

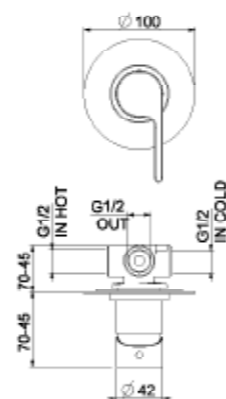

.015 Cromo / Chrome / Chromée / Verchromt / Cromado € 120,00



## DR860101

Kg 2,5  
Box pcs 5



PER FINITURE CONSULTARE  
SEZIONE EASY BATHROOM A PAG. 260

FOR ALL AVAILABLE FINISHINGS  
PLEASE GO TO EASY BATHROOM P. 260

Miscelatore monocomando per vasca incasso, con deviatore automatico e piastra; senza flessibile, doccetta e gancio di supporto.

Concealed single lever bath mixer with automatic diverter, cover plate, without shower set.

Mitigeur bain-douche à encastrer avec inverseur automatique, rosace, sans garniture de douche.

Einhebelmischer Unterputz-Badebatterie mit Umstellung, Rosette, ohne Brausegarnitur.

Monomando empotrable para bañera, con desviador automático, placa, sin tubo flexible, ducha ni gancho de soporte.



.015 Cromo / Chrome / Chromée / Verchromt / Cromado € 220,00

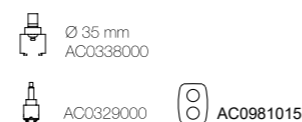

## DR850102

Kg 2,9  
Box pcs 12



153 + € 15,00

Miscelatore monocomando per vasca esterno senza flessibile; senza doccetta e gancio di supporto.

Single lever bath mixer without shower set.

Mitigeur bain-douche sans garniture de douche.

Einhebelmischer Badebatterie ohne Brausegarnitur.

Monomando externo para bañera, sin tubo flexible, ducha ni gancho de soporte.

.015 Cromo / Chrome / Chromée / Verchromt / Cromado € 178,00

.560 Nero opaco / Matt black / Noir mat / Matt Schwarz / Negro mate € 249,00

.345 Acciaio spazzolato / Brushed nickel / Acier brossé / Edelstahl Optik / Acero cepillado € 285,00

Color Lab € 264,00

Collezione Primavera € 285,00

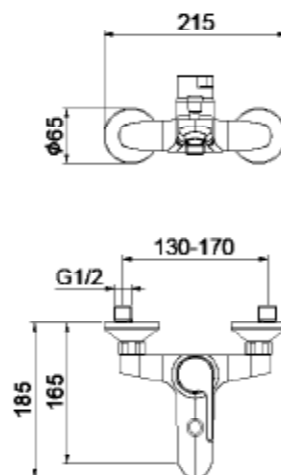

## DR870102

Kg 1,9  
Box pcs 12



153 + € 15,00

Miscelatore monocomando per doccia esterno, senza flessibile; senza doccetta e gancio di supporto.

Single lever shower mixer without shower set.

Mitigeur de douche sans garniture de douche.

Einhebelmischer Brausebatterie ohne Brausegarnitur.

Monomando externo para ducha, sin tubo flexible, ducha ni gancho de soporte.

.015 Cromo / Chrome / Chromée / Verchromt / Cromado € 105,00

.560 Nero opaco / Matt black / Noir mat / Matt Schwarz / Negro mate € 147,00

.345 Acciaio spazzolato / Brushed nickel / Acier brossé / Edelstahl Optik / Acero cepillado € 168,00

Color Lab € 162,00

Collezione Primavera € 168,00

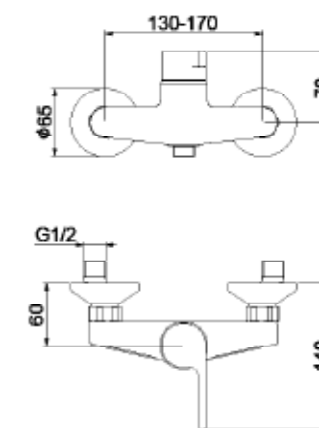

# KIMONO



KI830101.015  
Miscelatore lavabo.  
One hole basin mixer.

Finiture / finishes / finitions / ausföhrungen / acabados

.015  
Cromo  
Chrome  
Chromé  
Verchromt  
Cromado



KI860101.015  
Miscelatore vasca incasso.  
Concealed bath mixer.

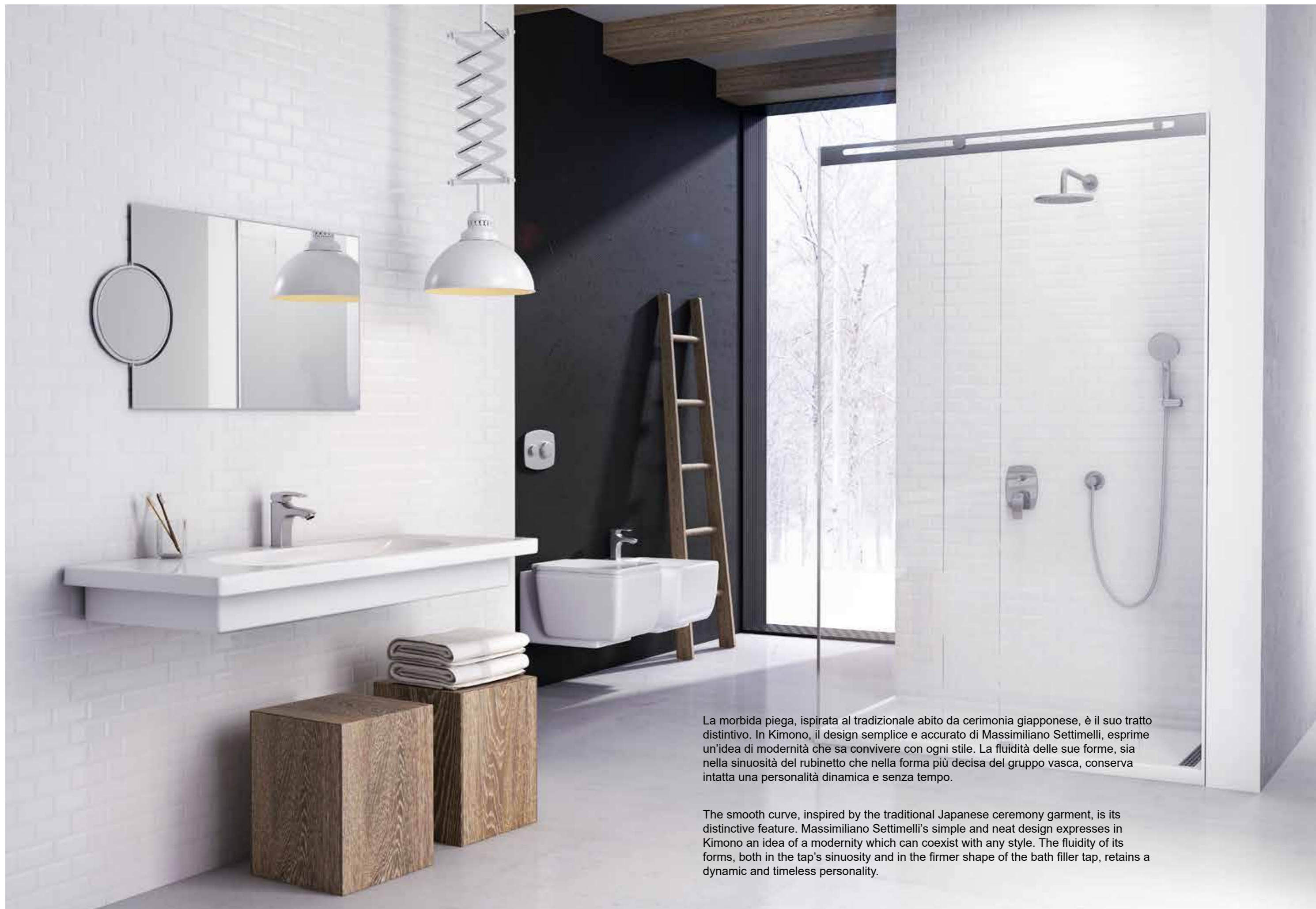

La morbida piega, ispirata al tradizionale abito da cerimonia giapponese, è il suo tratto distintivo. In Kimono, il design semplice e accurato di Massimiliano Settimelli, esprime un'idea di modernità che sa convivere con ogni stile. La fluidità delle sue forme, sia nella sinuosità del rubinetto che nella forma più decisa del gruppo vasca, conserva intatta una personalità dinamica e senza tempo.

The smooth curve, inspired by the traditional Japanese ceremony garment, is its distinctive feature. Massimiliano Settimelli's simple and neat design expresses in Kimono an idea of a modernity which can coexist with any style. The fluidity of its forms, both in the tap's sinuosity and in the firmer shape of the bath filler tap, retains a dynamic and timeless personality.

## KI830101

Kg 1,9  
Box pcs 12



Miscelatore monocomando per lavabo con scarico 1"1/4 con flex inox cm 37 att. 3/8" F.

Single lever washbasin mixer with 1"1/4 pop-up waste and 3/8" F flex. hoses cm 37.

Mitigeur de lavabo avec vidage automatique 1"1/4 et flexibles d'alimentation cm 37 3/8" F.

Einhebelmischer Waschtischbatterie mit Ablaufgarnitur 1" 1/4 und flex. Anschlussschläuchen cm 37 3/8" F.

Monomando para lavabo con desagüe 1" 1/4, tubo flexible inoxidable de 37 cm, empalme 3/8" F.

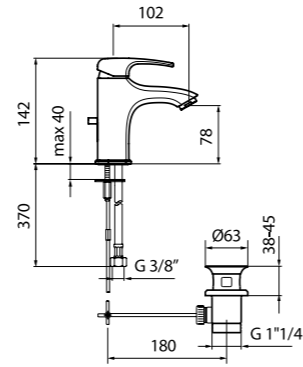

KI830102

.015 Cromo / Chrome / Chromée / Verchromt / Cromado € 130,00

AC0462015 Ø 35 mm AC0361000

## KI840101

Kg 1,6  
Box pcs 12



Miscelatore monocomando per bidet con scarico 1"1/4 con flex inox cm 37 att. 3/8" F.

Single lever bidet mixer with 1"1/4 pop-up waste and 3/8" F flex. hoses cm 37.

Mitigeur de bidet avec vidage automatique 1"1/4 et flexibles d'alimentation cm 37 3/8" F.

Einhebelmischer Bidetbatterie mit Ablaufgarnitur 1" 1/4 und flex. Anschlussschläuchen cm. 37 3/8" F.

Monomando para bidé con desagüe 1" 1/4, tubo flexible inoxidable de 37 cm, empalme 3/8" F.

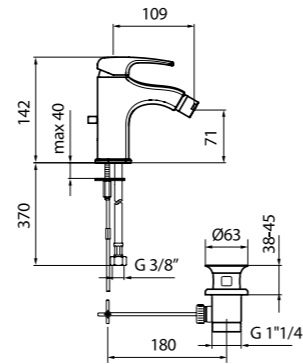

KI840102

.015 Cromo / Chrome / Chromée / Verchromt / Cromado € 130,00

AC0465015 Ø 35 mm AC0361000

## KI850101

Kg 2,9  
Box pcs 12



Miscelatore monocomando per vasca esterno completo con flessibile da 150 cm doccia multifunzione anticalcare e supporto.

Single lever bath mixer with shower set complete of hose 150 cm, multifunction handshower and holder.

Mitigeur bain-douche complet de flexible 150 cm, douchette multijet et support mural.

Einhebelmischer Badebatterie mit Brausegarnitur bestehend aus Brauseschlauch 150 cm, Massagehandbrause und Wandhalterung.

Monomando externo para bañera completo, con tubo flexible de 150 cm, ducha masaje antical y soporte.

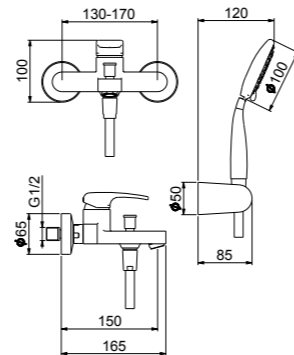

KI850102 + € 15,00

.015 Cromo / Chrome / Chromée / Verchromt / Cromado € 220,00

AC0463015 Ø 35 mm AC0338000

## KI870102

Kg 1,9  
Box pcs 12



Miscelatore monocomando per doccia esterno; senza flessibile, senza doccia e gancio di supporto.

Single lever shower mixer without shower set.

Mitigeur de douche sans garniture de douche.

Einhebelmischer Brausebatterie ohne Brausegarnitur.

Monomando externo para ducha, sin tubo flexible, ducha ni gancho de soporte.

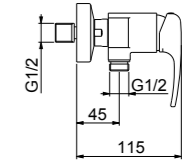
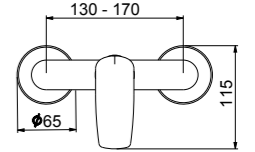

KI870102 + € 15,00

.015 Cromo / Chrome / Chromée / Verchromt / Cromado € 137,00

AC0363015 Ø 35 mm AC0338000

## KI880101

Kg 1,1  
Box pcs 12



Miscelatore monocomando per doccia incasso, con piastra, senza flessibile, doccia e gancio.

Concealed single lever shower mixer with cover plate, without shower set.

Mitigeur de douche à encastrer avec rosace, sans garniture de douche.

Einhebelmischer Unterputz-Brausebatterie, mit Rosette ohne Brausegarnitur.

Monomando empotrable para ducha, con placa, sin tubo flexible, ducha ni gancho.

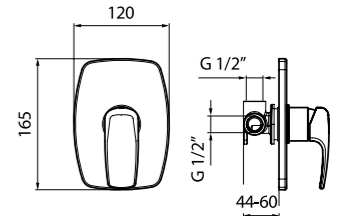

AC0691015

KI880102

.015 Cromo / Chrome / Chromée / Verchromt / Cromado € 87,00

AC0363 Ø 35 mm AC0338000

## KI860101

Kg 1,7  
Box pcs 12



Miscelatore monocomando per vasca incasso, con deviatore automatico e piastra, senza flessibile, doccia e gancio di supporto.

Concealed single lever bath mixer with automatic diverter, cover plate, without shower set.

Mitigeur bain-douche à encastrer avec inverseur automatique, rosace, sans garniture de douche.

Einhebelmischer Unterputz-Badebatterie mit Umstellung, Rosette, ohne Brausegarnitur.

Monomando empotrable para bañera, con desviador automático, placa, sin tubo flexible, ducha ni gancho de soporte.

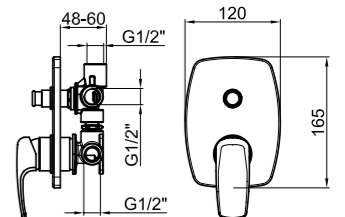

KI860102 + € 15,00

.015 Cromo / Chrome / Chromée / Verchromt / Cromado € 155,00

AC0364 Ø 35 mm AC0338000

# OTTOCENTO



OT700101.065  
Miscelatore lavabo.  
One hole basin mixer.

Forme classiche e dettagli d'epoca si fondono con le migliori tecnologie di oggi. Ecco Ottocento, con le sue linee sinuose, le eleganti manopole a crociera e gli inserti bianchi in porcellana. Una collezione raffinata dalla funzionalità eccellente, capace di infondere a tutto l'ambiente bagno quel tocco di passato, che non perde mai il suo fascino.

Classic forms and vintage details merge with today's top technologies. This is what Ottocento is about: sinuous lines, elegant cross knobs and white porcelain inserts. A sophisticated collection with excellent functionality, able to infuse the bathroom with that touch of past which never loses its charm.



OT690101.065  
Rubinetto arresto incasso.  
Stop cock.

AC0395.065  
Deviatore vasca incasso.  
Diverter for concealed bath mixer.

## Finiture / finishes / finitions / ausföhrungen / acabados

.015  
Cromo  
Chrome  
Chromé  
Verchromt  
Cromado

.010  
Oro  
Gold  
Doré  
Gold  
Oro

.065  
Bronzato  
Bronze  
Bronze  
Bronze  
Bronze



## OT700101

 Kg 2,3  
Box pcs 12



Monoforo monoblocco per lavabo con scarico 1"1/4 con flex inox cm 37 att. 3/8" F.

Monobloc washbasin mixer with 1"1/4 pop-up waste and 3/8" F flex. hoses cm 37.

Mélangeur de lavabo monotrou avec vidage automatique 1"1/4 et flexibles d'alimentation cm 37 3/8" F.

Waschtisch-Einlochbatterie mit Ablaufgarnitur 1" 1/4 und flex. Anschlussschläuchen cm. 37 3/8" F.

Grifo bimando para lavabo, desagüe 1"1/4, tubo flexible inoxidable de 37 cm y conexión 3/8" F.

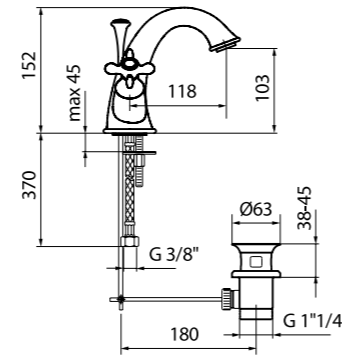

- .015 Cromo / Chrome / Chromée / Verchromt / Cromado € 191,00
- .010 Oro / Gold / Doré / Gold / Oro € 244,00
- .065 Bronzato / Bronze / Bronze / Bronze / Bronze € 232,00

 AC0462015  AC0331000

 OT700102

## OT710101

 Kg 2,1  
Box pcs 12



Monoforo monoblocco per bidet con scarico 1"1/4 con flex inox cm 37 att. 3/8" F.

Monobloc bidet mixer with 1"1/4 pop-up waste and 3/8" F flex. hoses cm 37.

Mélangeur de bidet monotrou avec vidage automatique 1"1/4 et flexibles d'alimentation cm 37 3/8" F.

Bidet-Einlochbatterie mit Ablaufgarnitur 1" 1/4 und flex Anschlussschläuchen cm. 37 3/8" F.

Grifo bimando para bidé, desagüe 1"1/4, tubo flexible inoxidable de 37 cm y conexión 3/8" F.

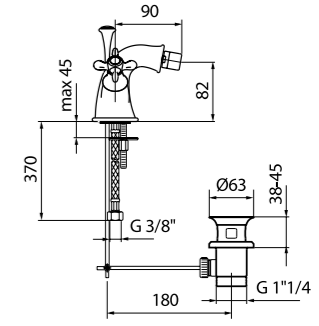

- .015 Cromo / Chrome / Chromée / Verchromt / Cromado € 184,00
- .010 Oro / Gold / Doré / Gold / Oro € 232,00
- .065 Bronzato / Bronze / Bronze / Bronze / Bronze € 218,00

 AC0465015  AC0331000

 OT710102

## OT750101

 Kg 3,5  
Box pcs 4



Batteria per lavabo a tre fori completa con scarico 1"1/4.

3-holes washbasin mixer with 1"1/4 pop-up waste.

Mélangeur de lavabo 3-trous bec fixe avec vidage automatique 1"1/4.

3-Loch-Waschtischbatterie mit Ablaufgarnitur 1" 1/4.

Grifo bimando para lavabo de repisa, 3 agujeros, desagüe 1"1/4.

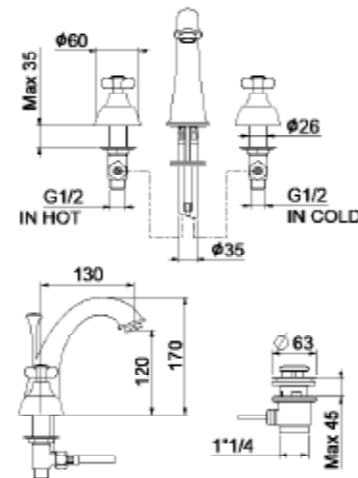

- .015 Cromo / Chrome / Chromée / Verchromt / Cromado € 237,00
- .010 Oro / Gold / Doré / Gold / Oro € 302,00
- .065 Bronzato / Bronze / Bronze / Bronze / Bronze € 278,00

 AC0462015  AC0331000

## OT710202

 Kg 3  
Box pcs 4



Batteria per bidet a tre fori completa con scarico 1"1/4.

3-holes bidet mixer with 1"1/4 pop-up waste.

Mélangeur de bidet 3-trous avec vidage automatique 1"1/4.

3-Loch Bidetbatterie mit Ablaufgarnitur 1" 1/4.

Grifo bimando para bidé de repisa, 3 agujeros, desagüe 1"1/4.

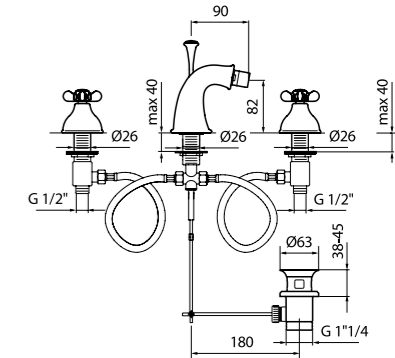

- .015 Cromo / Chrome / Chromée / Verchromt / Cromado € 240,00
- .010 Oro / Gold / Doré / Gold / Oro € 307,00
- .065 Bronzato / Bronze / Bronze / Bronze / Bronze € 271,00

 AC0465015  AC0331000

 OT710102

## OT750202

 Kg 3,4  
Box pcs 4



Batteria per lavabo a tre fori con bocca girevole, con scarico 1"1/4.

3-holes washbasin mixer swivel spout, with 1"1/4 pop-up waste.

Mélangeur de lavabo 3-trous bec mobile, avec vidage automatique 1"1/4.

3-Loch-Waschtischbatterie mit schwenkbarem Auslauf und Ablaufgarnitur 1" 1/4.

Grifo empotrable de pared para lavabo, 3 agujeros, con caño giratorio, desagüe 1"1/4.

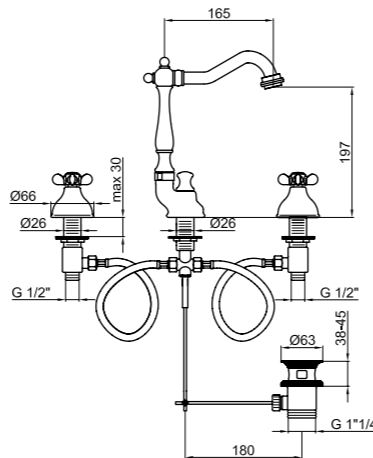

- .015 Cromo / Chrome / Chromée / Verchromt / Cromado € 300,00
- .010 Oro / Gold / Doré / Gold / Oro € 432,00
- .065 Bronzato / Bronze / Bronze / Bronze / Bronze € 411,00

 AC0757015  AC0331000

## OT750404

 Kg 1,8  
Box pcs 12



Batteria per lavabo a 3 fori incasso muro.

Concealed 3-holes washbasin mixer.

Mélangeur de lavabo 3 trous à encastrer.

Unterputz - 3-Loch-Waschtischbatterie.

Grifo empotrable de pared para lavabo, 3 agujeros.

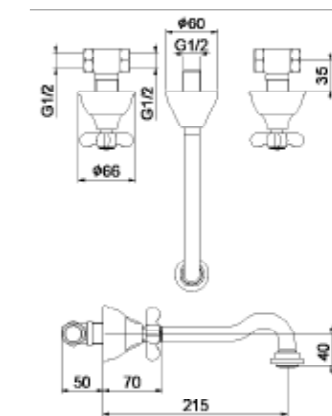

- .015 Cromo / Chrome / Chromée / Verchromt / Cromado € 273,00
- .010 Oro / Gold / Doré / Gold / Oro € 344,00
- .065 Bronzato / Bronze / Bronze / Bronze / Bronze € 312,00

 AC0757015  AC0331000

## OT700301

 Kg 2,2  
Box pcs 8



Monoforo per lavabo con scarico 1"1/4 con flex inox cm 37 att. 3/8" F.

Monobloc washbasin mixer with 1"1/4 pop-up waste and 3/8" F flex. hoses cm 37.

Mélangeur de lavabo monotrou avec vidage automatique 1"1/4 et flexibles d'alimentation cm 37 3/8" F.

Waschtisch-Einlochbatterie mit Ablaufgarnitur 1" 1/4 und flex. Anschlußschläuchen cm. 37 3/8" F.

Grifo bimando para lavabo, desagüe 1"1/4, tubo flexible inoxidable de 37 cm y conexión 3/8" F.

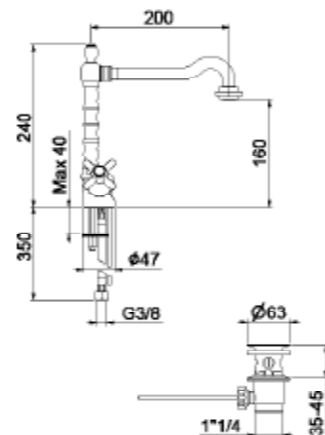

.015 Cromo / Chrome / Chromée / Verchromt / Cromado € 184,00

.010 Oro / Gold / Doré / Gold / Oro € 260,00

.065 Bronzato / Bronze / Bronze / Bronze / Bronze € 250,00

 AC0757015

 AC0331000

 OT700302

## OT710401

 Kg 2,1  
Box pcs 8



Monoforo per bidet con scarico 1"1/4 con flex inox cm 37 att. 3/8" F.

Monobloc bidet mixer with 1"1/4 pop-up waste and 3/8" F flex. hoses cm 37.

Mélangeur de bidet monotrou avec vidage automatique 1"1/4 et flexibles d'alimentation cm 37 3/8" F.

Bidet-Einlochbatterie mit Ablaufgarnitur 1" 1/4 Anschlussschläuchen cm. 37 3/8" F.

Grifo bimando para bidet, desagüe 1"1/4, tubo flexible inoxidable de 37 cm y conexión 3/8" F.

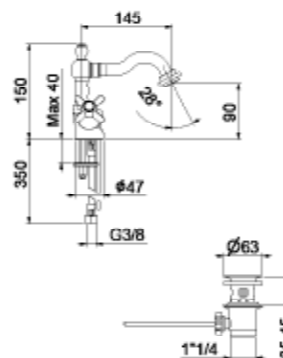

.015 Cromo / Chrome / Chromée / Verchromt / Cromado € 184,00

.010 Oro / Gold / Doré / Gold / Oro € 260,00

.065 Bronzato / Bronze / Bronze / Bronze / Bronze € 250,00

 AC0758015

 AC0331000

 OT710402

## OT720201

 Kg 3,5  
Box pcs 6



Gruppo per vasca esterno completo con flessibile in ottone da 150 cm, doccetta monogetto.

Bath mixer with shower set complete of brass hose 150 cm. and monospray handshower.

Mélangeur bain-douche complet de flexible en laiton 150 cm et douchette monojet.

Badebatterie mit Brausegarnitur bestehend aus Metall-Brauseschlauch 150 cm. und Mono-Wasserstrahl Handbrause.

Grupo externo para bañera, con tubo flexible de latón, flexible 150 cm y ducha.

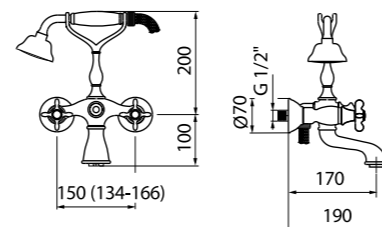

.015 Cromo / Chrome / Chromée / Verchromt / Cromado € 355,00

.010 Oro / Gold / Doré / Gold / Oro € 475,00

.065 Bronzato / Bronze / Bronze / Bronze / Bronze € 443,00

 AC0829015

 AC0463015

 AC0331000

 OT720201

## OT730101

 Kg 5,1  
Box pcs 3



Gruppo per bordo vasca 5 fori completo con flessibile in ottone da 150 cm e doccetta monogetto.

5-holes deck mounted bath mixer complete of brass hose 150 cm and monospray handshower.

Mélangeur bain-douche 5-trous, flexible en laiton 150 cm et douchette monojet.

5-Loch-Wannenrandarmatur mit Metallbrauseschlauch 150 cm. und Mono-Wasserstrahl Handbrause.

Grupo para borde de bañera, 5 agujeros, con tubo flexible de latón, longitud 150 cm y ducha.

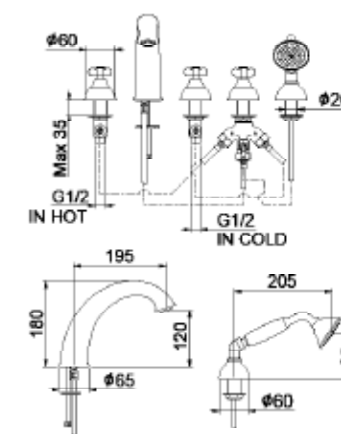

Diametro foratura pannello vasca A-B-C-D = 28 mm  
Massimo spessore pannello vasca 35 mm

Diameter of the bath deck drilling A-B-C-D = 28 mm  
Largest thickness of the bath deck 35 mm

Diamètre perçage du bord de la baignoire A-B-C-D = 28 mm  
Maximum épaisseur du bord de la baignoire 35 mm

Bohrungsdurchmesser der Wannenrandarmatur A-B-C-D = 28 mm  
Grösste Dicke der Wannenrandarmatur 35 mm

Diámetro agujero borde de bañera A-B-C-D = 28 mm  
Máximo espesor borde de bañera 35 mm

.015 Cromo / Chrome / Chromée / Verchromt / Cromado € 430,00

.010 Oro / Gold / Doré / Gold / Oro € 542,00

.065 Bronzato / Bronze / Bronze / Bronze / Bronze € 516,00

 AC0463015

 AC0331000

## OT760101

 Kg 2,5  
Box pcs 12



Gruppo per doccia esterno completo con flessibile in ottone da 150 cm, doccetta e gancio di supporto.

Shower mixer with shower set complete of brass hose 150 cm, handshower and holder.

Mélangeur de douche complet de flexible en laiton 150 cm, douchette et support mural.

Brausebatterie mit Brausegarnitur bestehend aus Metall-Brauseschlauch 150 cm, Handbrause und Wandhalterung.

Grupo externo para ducha, con tubo flexible de latón, flexible 150 cm; rociador y soporte.

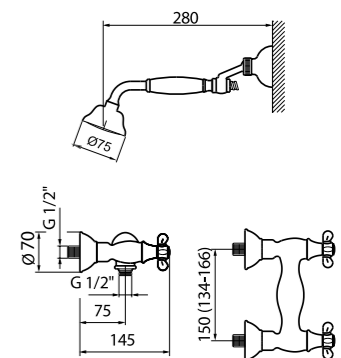

.015 Cromo / Chrome / Chromée / Verchromt / Cromado € 230,00

.010 Oro / Gold / Doré / Gold / Oro € 335,00

.065 Bronzato / Bronze / Bronze / Bronze / Bronze € 302,00

 AC0331000

## OT720801

 Kg 9,8  
Box pcs 2



Gruppo per vasca esterno con bocca integrale, con colonne a pavimento, flessibile e doccetta monogetto.

Bath mixer with floor connections and monospray shower set.

Mélangeur bain/douche avec raccords sur pieds et garniture de douche monojet.

Badebatterie mit Standverschraubungen und Mono-Wasserstrahl Brausegarnitur.

Grupo externo para bañera, con columnas de toma de agua de suelo.

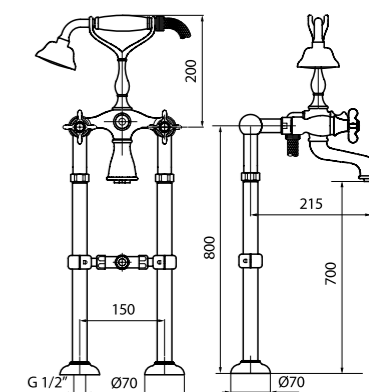

.015 Cromo / Chrome / Chromée / Verchromt / Cromado € 879,00

.010 Oro / Gold / Doré / Gold / Oro € 1.011,00

.065 Bronzato / Bronze / Bronze / Bronze / Bronze € 986,00

 AC0829015

 AC0463015

 AC0331000

## OT760405

 Kg 4,3  
Box pcs 1

 Kg 1,8  
Box pcs 1



Gruppo doccia esterno, versione completa di colonna, soffione e doccetta monogetto.

Shower mixer with shower column, shower head and mono-spray handshower.

Mélangeur de douche avec colonne, pomme de douche et garniture de douche mono-jet.

Brausebatterie mit Gleitstange, Kopfbrause und Mono-Wasserstrahe Handbrause.

Grupo externo para ducha, versión completa con columna, rociador y ducha.

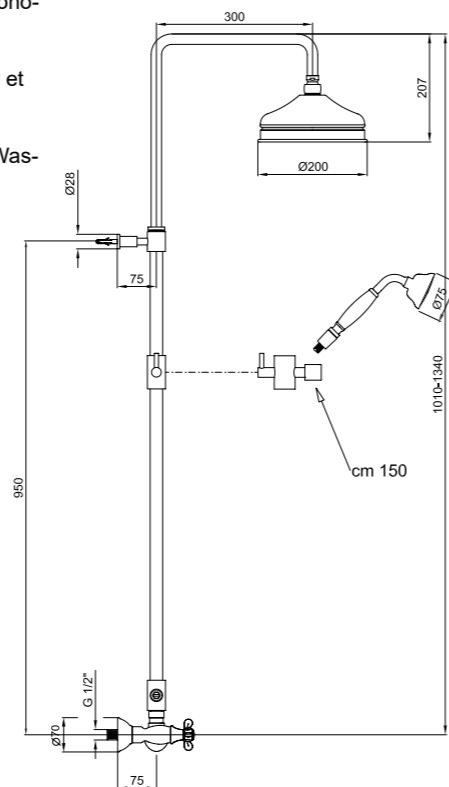
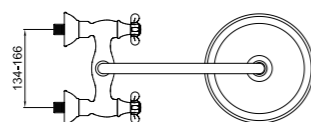

- .015 Cromo / Chrome / Chromée / Verchromt / Cromado € 616,00
- .010 Oro / Gold / Doré / Gold / Oro € 1.028,00
- .065 Bronzato / Bronze / Bronze / Bronze / Bronze € 1.001,00



153

## OT721208

 Kg 4,3  
Box pcs 1

 Kg 2,5  
Box pcs 1



Miscelatore monocomando per vasca esterno, versione completa di colonna, soffione e doccetta monogetto.

Bath mixer with column, shower head and monospray handshower.

Mélangeur debain/douche avec colonne, pomme de douche et douchette monojet.

Badebatterie mit Brausegleitstange, Brausekopf und 1 Funktion Handbrause.

Monomando externo para bañera, versión con columna, rociador y ducha.

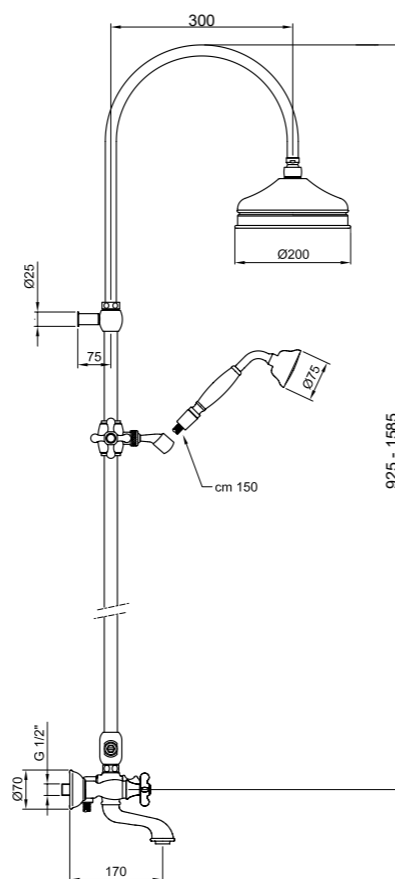
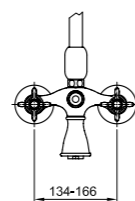

- .015 Cromo / Chrome / Chromée / Verchromt / Cromado € 790,00
- .010 Oro / Gold / Doré / Gold / Oro € 1.232,00
- .065 Bronzato / Bronze / Bronze / Bronze / Bronze € 1.138,00



153

## OT690101

 Kg 0,6  
Box pcs 16



Rubinetto di arresto ad incasso; attacco da 1/2"; venduto singolo.

Stop cock 1/2" singly sold.

Robinet à encastrer 1/2" vendu single.

Unterputzventil 1/2" einzeln verkauft.

Llave de paso conexión de 1/2", vendido singularmente.

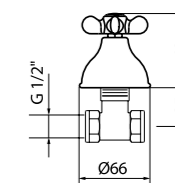

- .015 Cromo / Chrome / Chromée / Verchromt / Cromado € 60,00
- .010 Oro / Gold / Doré / Gold / Oro € 79,00
- .065 Bronzato / Bronze / Bronze / Bronze / Bronze € 74,00



## AC0395

 Kg 0,5  
Box pcs 16



Deviatore vasca incasso 2 vie.

2 ways diverter for concealed bath mixer.

Inverseur 2 voies pour mitigeur de bain/douche encastré.

2-Weg Umsteller für Unterputz-Badebatterie.

Desviador 2 vias para monomando empotrable para bañera.

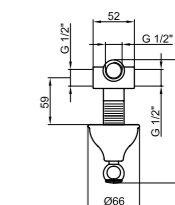

- .015 Cromo / Chrome / Chromée / Verchromt / Cromado € 144,00
- .010 Oro / Gold / Doré / Gold / Oro € 208,00
- .065 Bronzato / Bronze / Bronze / Bronze / Bronze € 189,00

## OT970902

 Kg 2,2  
Box pcs 10



Miscelatore termostatico per doccia incasso, con deviatore due vie, senza flessibile, doccetta e gancio.

Concealed thermostatic shower mixer with diverter 2-way, without shower set.

Mitigeur de douche thermostatique à encastrer avec inverseur 2 voies, sans garniture de douche.

Thermostat Unterputz Brausemischer, mit 2-Wege-Umsteller, ohne Garnitur.

Termostatica de encastre para Duchas 2 vias sin tubo flexible, ducha ni gancio.

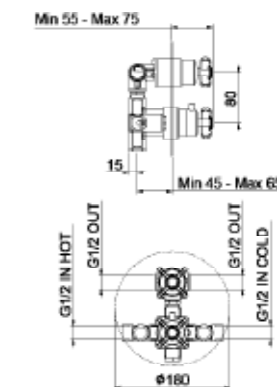

- .015 Cromo / Chrome / Chromée / Verchromt / Cromado € 318,00
- .010 Oro / Gold / Doré / Gold / Oro € 539,00
- .065 Bronzato / Bronze / Bronze / Bronze / Bronze € 454,00

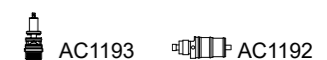

## AM500701

 Kg 2,1  
Box pcs 2



Mensola in vetro.

Glass shelf.

Etagère en verre.

Ablage aus Glas.

Repisa de vidrio.

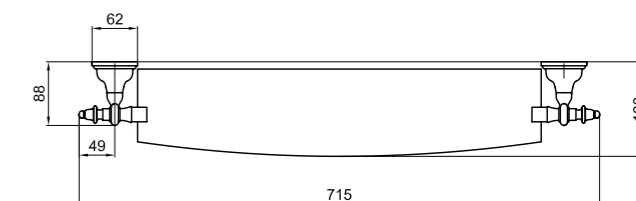

- .015 Cromo / Chrome / Chromée / Verchromt / Cromado € 222,00
- .010 Oro / Gold / Doré / Gold / Oro € 311,00
- .065 Bronzato / Bronze / Bronze / Bronze / Bronze € 289,00

### AM500501

Kg 0,8  
Box pcs 2



Porta asciugamano in ottone.  
Brass towel holder.  
Porte serviette en laiton.  
Handtuchhalter aus Messing.  
Toallero de latón.

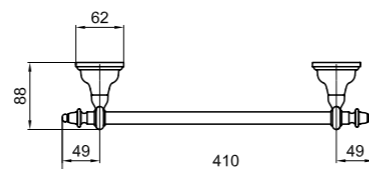

.015 Cromo / Chrome / Chromée / Verchromt / Cromado € 148,00  
.010 Oro / Gold / Doré / Gold / Oro € 210,00  
.065 Bronzato / Bronze / Bronze / Bronze / Bronze € 195,00

### AM500101

Kg 0,7  
Box pcs 10



Portasapone in ottone.  
Soap holder in brass.  
Porte savon en laiton.  
Seifenschale mit Becher aus Messing.  
Jabonera de latón.

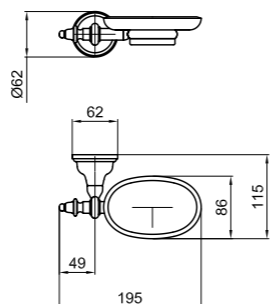

.015 Cromo / Chrome / Chromée / Verchromt / Cromado € 120,00  
.010 Oro / Gold / Doré / Gold / Oro € 168,00  
.065 Bronzato / Bronze / Bronze / Bronze / Bronze € 160,00

### AM500301

Kg 0,5  
Box pcs 10



Portabicchiere in ottone.  
Tumbler holder in brass.  
Porte verre en laiton.  
Becherhalter aus Messing.  
Portavaso de latón.

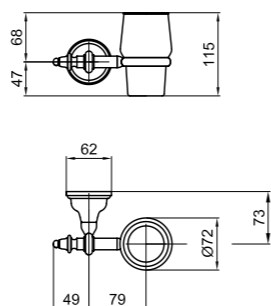

.015 Cromo / Chrome / Chromée / Verchromt / Cromado € 120,00  
.010 Oro / Gold / Doré / Gold / Oro € 168,00  
.065 Bronzato / Bronze / Bronze / Bronze / Bronze € 160,00

### AM500201

Kg 0,6  
Box pcs 10



Portasapone liquido in ottone.  
Brass soap dispenser.  
Distributeur de savon en laiton.  
Seifenspender aus Messing.  
Dosificador de latón.

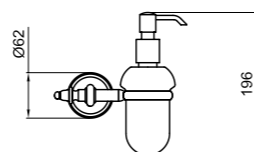

.015 Cromo / Chrome / Chromée / Verchromt / Cromado € 161,00  
.010 Oro / Gold / Doré / Gold / Oro € 227,00  
.065 Bronzato / Bronze / Bronze / Bronze / Bronze € 216,00

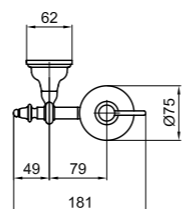

### AM500801

Kg 0,5  
Box pcs 10



Porta rotolo.  
Toilet roll holder.  
Support en laiton pour papier rouleaux.  
Toilettenpapierhalter aus Messing.  
Portarrotolo de latón.

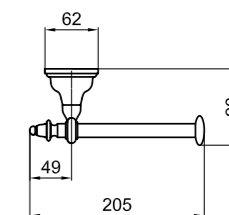

.015 Cromo / Chrome / Chromée / Verchromt / Cromado € 92,00  
.010 Oro / Gold / Doré / Gold / Oro € 126,00  
.065 Bronzato / Bronze / Bronze / Bronze / Bronze € 110,00

### AM500401

Kg 0,4  
Box pcs 12



Appendino in ottone.  
Hook in brass.  
Peignoir en laiton.  
Haken aus Messing.  
Percha en latón.

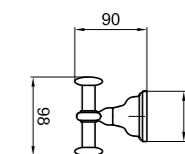

.015 Cromo / Chrome / Chromée / Verchromt / Cromado € 91,00  
.010 Oro / Gold / Doré / Gold / Oro € 145,00  
.065 Bronzato / Bronze / Bronze / Bronze / Bronze € 135,00

### AM501302

Kg 1  
Box pcs 2



Porta scopino ovale in ottone a pavimento.  
Free standing brass oval-shaped toilet brush holder.  
Porte balai WC au sol ovale, en laiton.  
Oval WC-Bürstenständer aus Messing.  
Escobillero oval de suelo.

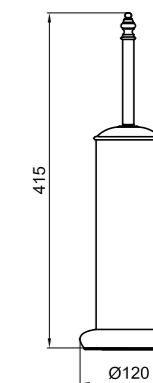

.015 Cromo / Chrome / Chromée / Verchromt / Cromado € 137,00  
.010 Oro / Gold / Doré / Gold / Oro € 191,00  
.065 Bronzato / Bronze / Bronze / Bronze / Bronze € 182,00

# KARENINA



KA750101.010  
Miscelatore lavabo 3 fori.  
3-hole basin mixer.

Disegnata da Massimiliano Settimelli, Karenina è pensata per fare del bagno un ambiente ricercato, avvolgente e lussuoso. Le sue forme sinuose ed eleganti, le maniglie di cristallo: sono i dettagli che rendono ancora più raffinato un design che nasce già ricco e prezioso. Nel rubinetto o nel gruppo vasca, la manopola non cambia mai il suo aspetto.

Designed by Massimiliano Settimelli, Karenina has been conceived to make the bathroom a refined, engaging and luxurious space. Its sinuous and elegant forms, the crystal handles: these are details which further refine a design that is already rich and valuable. Neither in the tap nor in the bath filler tap does the knob change its look.



KA721208  
Miscelatore vasca con colonna.  
Bath mixer with column.

## Finiture / finishes / finitions / ausführungen / acabados

.015	.017	.010	.065
Cromo	Cromo-Oro	Oro	Bronzato
Chrome	Chrome-Gold	Gold	Bronze
Chromé	Chromé-Doré	Doré	Bronze
Verchromt	Chrom-Gold	Gold	Bronze
Cromado	Cromo-Oro	Oro	Bronze



## KA700101

 Kg 2,7  
Box pcs 12



Monoforo monoblocco per lavabo con scarico 1"1/4 con flex inox cm 37 att. 3/8" F.

Monobloc washbasin mixer with 1"1/4 pop-up waste and 3/8" F flex. hoses cm 37.

Mélangeur de lavabo monotrou avec vidage automatique 1"1/4 et flexibles d'alimentation cm 37 3/8" F.

Waschtisch-Einlochbatterie mit Ablaufgarnitur 1" 1/4 und flex. Anschlussschläuchen cm. 37 3/8" F.

Grifo bimando para lavabo, desagüe 1"1/4, tubo flexible inoxidable de 37 cm y conexión 3/8" F.

- .015 Cromo / Chrome / Chromée / Verchromt / Cromado € 319,00
- .017 Cromo-Oro / Chrome-Gold / Chromé-Or / Chrom-Gold / Cromo-Oro € 383,00
- .010 Oro / Gold / Doré / Gold / Oro € 334,00
- .065 Bronzato / Bronze / Bronze / Bronze / Bronze € 358,00

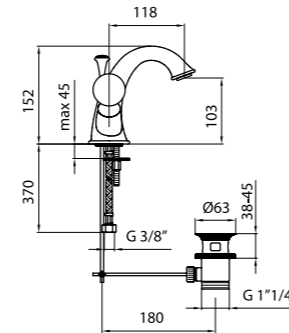

 flex  
AC0446

 AC0462015

 AC0331000

 KA700102

## KA750101

 Kg 3,7  
Box pcs 4



Batteria per lavabo a tre fori completa con scarico 1"1/4.

3-holes washbasin mixer with 1"1/4 pop-up waste.

Mélangeur de lavabo 3-trous bec fixe avec vidage automatique 1"1/4.

3-Loch-Waschtischbatterie mit Ablaufgarnitur 1" 1/4.

Grifo bimando para lavabo de repisa, 3 agujeros, desagüe 1"1/4.

- .015 Cromo / Chrome / Chromée / Verchromt / Cromado € 383,00
- .017 Cromo-Oro / Chrome-Gold / Chromé-Or / Chrom-Gold / Cromo-Oro € 455,00
- .010 Oro / Gold / Doré / Gold / Oro € 399,00
- .065 Bronzato / Bronze / Bronze / Bronze / Bronze € 422,00

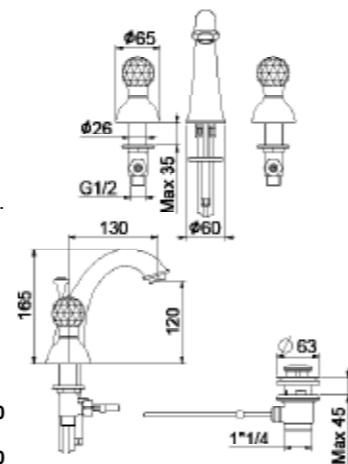

 AC0462015

 AC0331000

## KA750202

 Kg 3,5  
Box pcs 4



Batteria per lavabo a tre fori con bocca girevole, con scarico 1"1/4.

3-holes washbasin mixer swivel spout, with 1"1/4 pop-up waste.

Mélangeur de lavabo 3-trous bec mobile, avec vidage automatique 1"1/4.

3-Loch-Waschtischbatterie mit schwenkbarem Auslauf und Ablaufgarnitur 1" 1/4.

Grifo bimando para lavabo de repisa, 3 agujeros, con caño giratorio, desagüe 1"1/4.

- .015 Cromo / Chrome / Chromée / Verchromt / Cromado € 460,00
- .017 Cromo-Oro / Chrome-Gold / Chromé-Or / Chrom-Gold / Cromo-Oro € 557,00
- .010 Oro / Gold / Doré / Gold / Oro € 488,00
- .065 Bronzato / Bronze / Bronze / Bronze / Bronze € 528,00

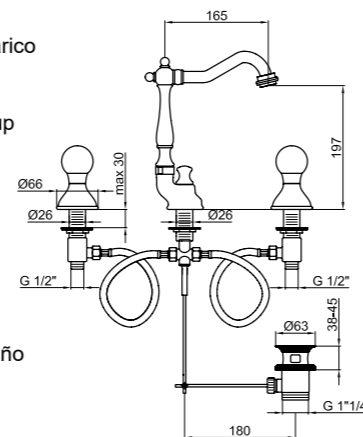

 AC0757015

 AC0331000

## KA710101

 Kg 2,4  
Box pcs 12



Monoforo monoblocco per bidet con scarico 1"1/4 con flex inox cm 37 att. 3/8" F.

Monobloc bidet mixer with 1"1/4 pop-up waste and 3/8" F flex. hoses cm 37.

Mélangeur de bidet monotrou avec vidage automatique 1"1/4 et flexibles d'alimentation cm 37 3/8" F.

Bidet-Einlochbatterie mit Ablaufgarnitur 1" 1/4 und flex Anschlussschläuchen cm. 37 3/8" F.

Grifo bimando para bidé, desagüe 1"1/4, tubo flexible inoxidable de 37 cm y conexión 3/8" F.

- .015 Cromo / Chrome / Chromée / Verchromt / Cromado € 319,00
- .017 Cromo-Oro / Chrome-Gold / Chromé-Or / Chrom-Gold / Cromo-Oro € 383,00
- .010 Oro / Gold / Doré / Gold / Oro € 334,00
- .065 Bronzato / Bronze / Bronze / Bronze / Bronze € 358,00

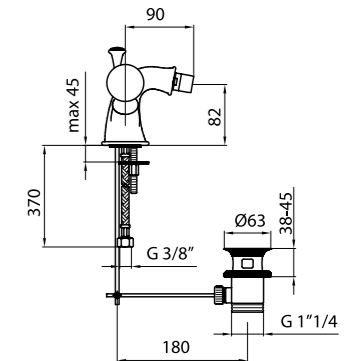

 flex  
AC0446

 AC0465015

 AC0331000

 KA710102

## KA710202

 Kg 3,7  
Box pcs 4



Batteria per bidet a tre fori completa con scarico 1"1/4.

3-holes bidet mixer with 1"1/4 pop-up waste.

Mélangeur de bidet 3-trous avec vidage automatique 1"1/4.

3-Loch Bidetbatterie mit Ablaufgarnitur 1" 1/4.

Grifo bimando para bidé de repisa, 3 agujeros, desagüe 1"1/4.

- .015 Cromo / Chrome / Chromée / Verchromt / Cromado € 390,00
- .017 Cromo-Oro / Chrome-Gold / Chromé-Or / Chrom-Gold / Cromo-Oro € 468,00
- .010 Oro / Gold / Doré / Gold / Oro € 409,00
- .065 Bronzato / Bronze / Bronze / Bronze / Bronze € 429,00

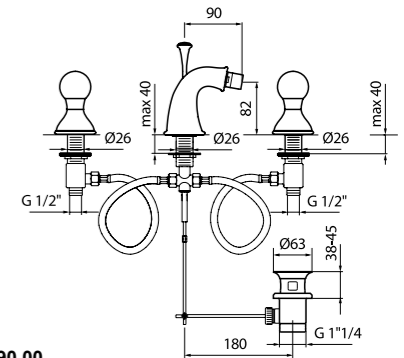

 AC0465015

 AC0331000

## KA750404

 Kg 2,2  
Box pcs 4



Batteria per lavabo a 3 fori incasso muro.

Concealed 3-holes washbasin mixer.

Mélangeur de lavabo 3 trous à encastrer.

Unterputz - 3-Loch-Waschtischbatterie.

Grifo empotrable de pared para lavabo, 3 agujeros.

- .015 Cromo / Chrome / Chromée / Verchromt / Cromado € 399,00
- .017 Cromo-Oro / Chrome-Gold / Chromé-Or / Chrom-Gold / Cromo-Oro € 470,00
- .010 Oro / Gold / Doré / Gold / Oro € 415,00
- .065 Bronzato / Bronze / Bronze / Bronze / Bronze € 438,00

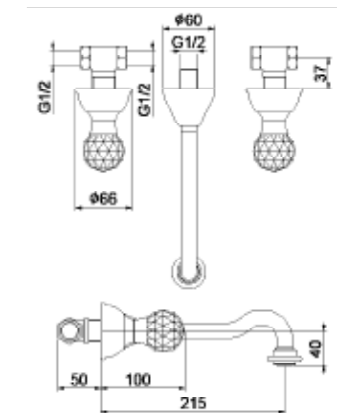

 AC0757015

 AC0331000

## KA720201

 Kg 4  
Box pcs 6



Gruppo per vasca esterno completo con flessibile in ottone da 150 cm, doccetta monogetto.

Bath mixer with shower set complete of brass hose 150 cm. and monospray handshower.

Mélangeur bain-douche complet de flexible en laiton 150 cm et douchette monojet.

Badebatterie mit Brausegarnitur bestehend aus Metall-Brauseschlauch 150 cm. und Mono-Wasserstrahe Handbrause.

Grupo externo para bañera, con tubo flexible de latón, flexible 150 cm y ducha.

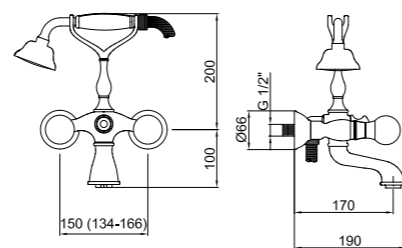

.015	Cromo / Chrome / Chromée / Verchromt / Cromado	€ 490,00
.017	Cromo-Oro / Chrome-Gold / Chromé-Or / Chrom-Gold / Cromo-Oro	€ 593,00
.010	Oro / Gold / Doré / Gold / Oro	€ 539,00
.065	Bronzato / Bronze / Bronze / Bronze / Bronze	€ 578,00



 + € 15,00

## KA730101

 Kg 5,5  
Box pcs 3



Gruppo per bordo vasca 5 fori completo con flessibile in ottone da 150 cm e doccetta monogetto.

5-holes deck mounted bath mixer complete of brass hose 150 cm and monospray handshower.

Mélangeur bain-douche 5-trous, flexible en laiton 150 cm et douchette monojet.

5-Loch-Wannenrandarmatur mit Metallbrauseschlauch 150 cm. und Mono-Wasserstrahe Handbrause.

Grupo para borde de bañera, 5 agujeros, con tubo flexible de latón, longitud 150 cm y ducha.

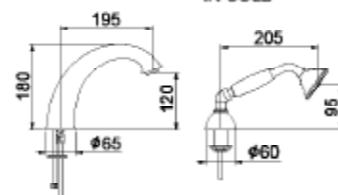
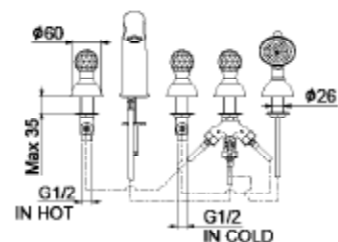

.015	Cromo / Chrome / Chromée / Verchromt / Cromado	€ 590,00
.017	Cromo-Oro / Chrome-Gold / Chromé-Or / Chrom-Gold / Cromo-Oro	€ 690,00
.010	Oro / Gold / Doré / Gold / Oro	€ 617,00
.065	Bronzato / Bronze / Bronze / Bronze / Bronze	€ 673,00



Diametro foratura pannello vasca A-B-C-D = 28 mm  
Massimo spessore pannello vasca 35 mm

Diameter of the bath deck drilling A-B-C-D = 28 mm  
Largest thickness of the bath deck 35 mm

Diamètre perçage du bord de la baignoire A-B-C-D = 28 mm  
Maximum épaisseur du bord de la baignoire 35 mm

Bohrungsdurchmesser der Wannenrandarmatur A-B-C-D = 28 mm  
Grösste Dicke der Wannenrandarmatur 35 mm

Diámetro agujero borde de bañera A-B-C-D = 28 mm  
Máximo espesor borde de bañera 35 mm

## KA690101

 Kg 0,7  
Box pcs 12



Rubinetto di arresto ad incasso; attacco da 1/2"; venduto singolo.

Stop cock 1/2" singly sold.

Robinet à encastrer 1/2" vendu single.

Unterputzventil 1/2" einzeln verkauft.

Llave de paso conexión de 1/2", vendido singularmente.

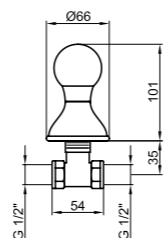

.015	Cromo / Chrome / Chromée / Verchromt / Cromado	€ 144,00
.017	Cromo-Oro / Chrome-Gold / Chromé-Or / Chrom-Gold / Cromo-Oro	€ 163,00
.010	Oro / Gold / Doré / Gold / Oro	€ 148,00
.065	Bronzato / Bronze / Bronze / Bronze / Bronze	€ 158,00



## KA720801

 Kg 8,8  
Box pcs 2



Gruppo per vasca esterno con bocca integrale, con colonne a pavimento, flessibile e doccetta monogetto.

Bath mixer with floor connections and monospray shower set.

Mélangeur bain/douche avec raccords sur pieds et garniture de douche monojet.

Badebatterie mit Standverschraubungen und Mono-Wasserstrahe Brausegarnitur.

Grupo externo para bañera, con columnas de toma de agua de suelo.

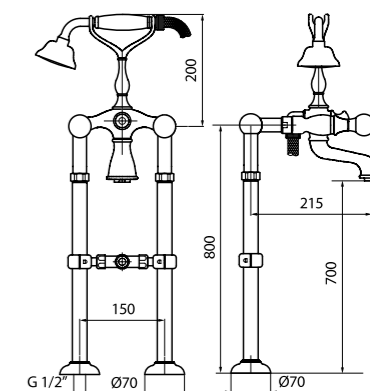

.015	Cromo / Chrome / Chromée / Verchromt / Cromado	€ 932,00
.017	Cromo-Oro / Chrome-Gold / Chromé-Or / Chrom-Gold / Cromo-Oro	€ 1.121,00
.010	Oro / Gold / Doré / Gold / Oro	€ 994,00
.065	Bronzato / Bronze / Bronze / Bronze / Bronze	€ 1.041,00

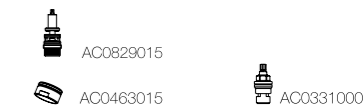

## KA721208

 Kg 4,3  
Box pcs 1

 Kg 3,8  
Box pcs 1



Miscelatore monocomando per vasca esterno, versione completa di colonna, soffione e doccetta monogetto.

Bath mixer with column, shower head and monospray handshower.

Mélangeur debain/douche avec colonne, pomme de douche et douchette monojet.

Badebatterie mit Brausegleitstange, Brausekopf und 1 Funktion Handbrause.

Monomando externo para bañera, versión con columna, rociador y ducha.

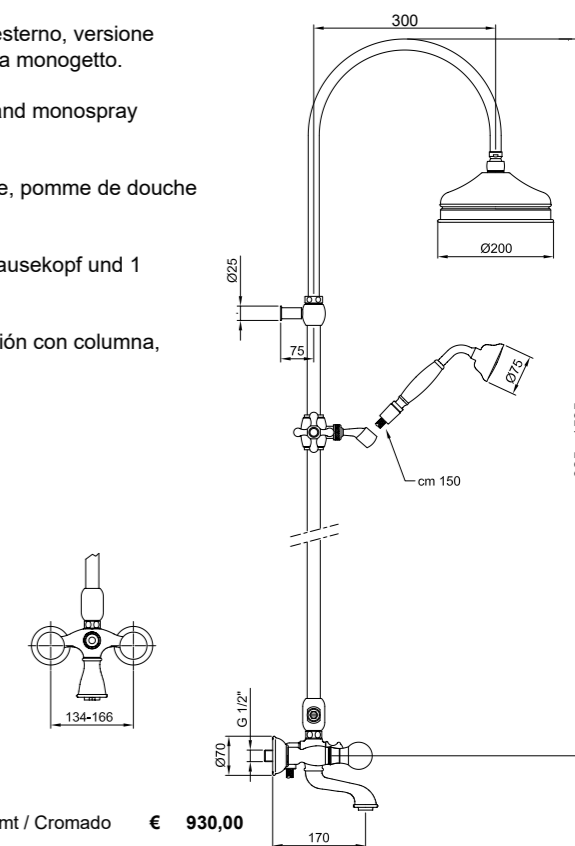

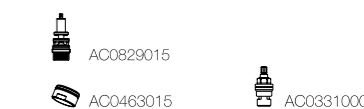

.015	Cromo / Chrome / Chromée / Verchromt / Cromado	€ 930,00
.017	Cromo-Oro / Chrome-Gold / Chromé-Or / Chrom-Gold / Cromo-Oro	€ 1.377,00
.010	Oro / Gold / Doré / Gold / Oro	€ 960,00
.065	Bronzato / Bronze / Bronze / Bronze / Bronze	€ 1.280,00



 + € 15,00

## KA760101

 Kg 1,9  
 Box pcs 12



Gruppo per doccia esterno completo con flessibile in ottone da 150 cm, doccetta e gancio di supporto.

Shower mixer with shower set complete of brass hose 150 cm, handshower and holder.

Mélangeur de douche complet de flexible en laiton 150 cm, douchette et support mural.

Brausebatterie mit Brausegarnitur bestehend aus Metall-Brauseschlauch 150 cm, Handbrause und Wandhalterung.

Grupo externo para ducha, con tubo flexible de latón, flexible 150 cm; rociador y soporte.

.015	Cromo / Chrome / Chromée / Verchromt / Cromado	€ 375,00
.017	Cromo-Oro / Chrome-Gold / Chromé-Or / Chrom-Gold / Cromo-Oro	€ 480,00
.010	Oro / Gold / Doré / Gold / Oro	€ 419,00
.065	Bronzato / Bronze / Bronze / Bronze / Bronze	€ 444,00

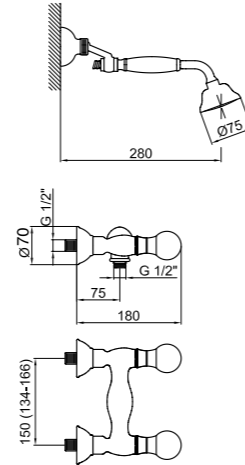

 + € 15,00

## KA760405

 Kg 4,3  
 Box pcs 1

 Kg 1,9  
 Box pcs 1



Gruppo doccia esterno, versione completa di colonna, soffione e doccetta monogetto.

Shower mixer with shower column, shower head and mono-spray handshower.

Mélangeur de douche avec colonne, pomme de douche et garniture de douche mono-jet.

Brausebatterie mit Gleitstange, Kopfbrause und Mono-Wasserstrahe Handbrause.

Grupo externo para ducha, versión completa con columna, rociador y ducha.

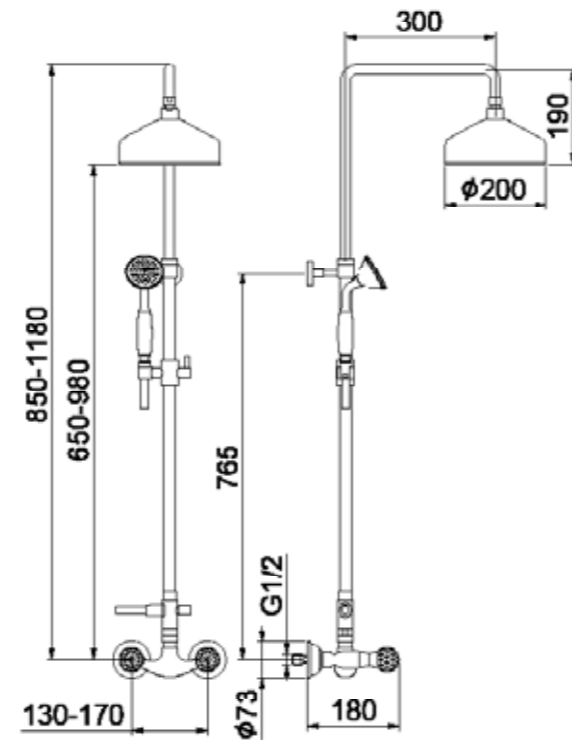



.015	Cromo / Chrome / Chromée / Verchromt / Cromado	€ 714,00
.017	Cromo-Oro / Chrome-Gold / Chromé-Or / Chrom-Gold / Cromo-Oro	€ 1.125,00
.010	Oro / Gold / Doré / Gold / Oro	€ 747,00
.065	Bronzato / Bronze / Bronze / Bronze / Bronze	€ 1.104,00





## AL880101

 Kg 1,2  
 Box pcs 12



Miscelatore monocomando per doccia incasso, con piastra, senza flessibile, doccetta e gancio.

Concealed single lever shower mixer with cover plate, without shower set.

Mitigeur de douche à encastrer avec rosace, sans garniture de douche.

Einhebelmischer Unterputz-Brausebatterie, mit Rosette ohne Brausegarnitur.

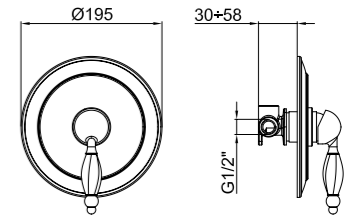

Monomando empotrable para ducha, con placa, sin tubo flexible, ducha ni gancho.

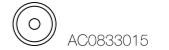
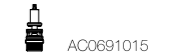

.015	Cromo / Chrome / Chromée / Verchromt / Cromado	€ 210,00
.017	Cromo-Oro / Chrome-Gold / Chromé-Or / Chrom-Gold / Cromo-Oro	€ 253,00
.010	Oro / Gold / Doré / Gold / Oro	€ 221,00
.065	Bronzato / Bronze / Bronze / Bronze / Bronze	€ 243,00



## AL860101

 Kg 1,9  
 Box pcs 12



Miscelatore monocomando per vasca incasso; con deviatore automatico; senza flessibile, doccetta e gancio di supporto.

Concealed single lever bath mixer with automatic diverter, without shower set.

Mitigeur bain-douche à encastrer avec inverseur automatique, sans garniture de douche.

Einhebelmischer Unterputz-Badebatterie mit Umstellung, ohne Brausegarnitur.

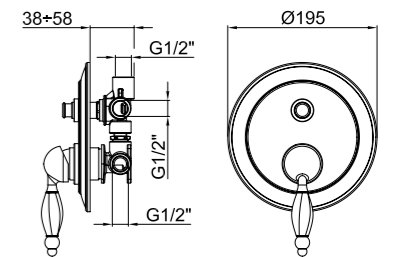

Monomando empotrable para bañera, con desviador automático; sin tubo flexible, ducha ni soporte.



.015	Cromo / Chrome / Chromée / Verchromt / Cromado	€ 288,00
.017	Cromo-Oro / Chrome-Gold / Chromé-Or / Chrom-Gold / Cromo-Oro	€ 331,00
.010	Oro / Gold / Doré / Gold / Oro	€ 298,00
.065	Bronzato / Bronze / Bronze / Bronze / Bronze	€ 320,00



## KA500801

 Kg 0,4  
 Box pcs 12



Porta rotolo.

Toilet roll holder.

Support en laiton pour papier rouleaux.

Toilettenpapierhalter aus Messing.

Portarollo de latón.

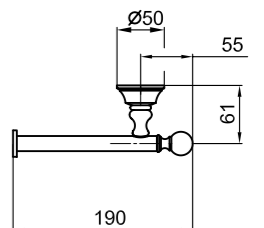

.015	Cromo / Chrome / Chromée / Verchromt / Cromado	€ 88,00
.017	Cromo-Oro / Chrome-Gold / Chromé-Or / Chrom-Gold / Cromo-Oro	€ 113,00
.010	Oro / Gold / Doré / Gold / Oro	€ 101,00
.065	Bronzato / Bronze / Bronze / Bronze / Bronze	€ 113,00

## KA500701

 Kg 1,9  
Box pcs 4

Mensola in vetro.  
Glass shelf.  
Etagère en verre.  
Ablage aus Glas.  
Repisa de vidrio.

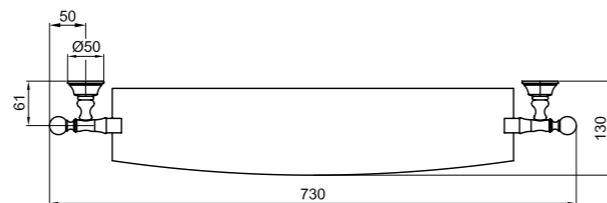

.015	Cromo / Chrome / Chromée / Verchromt / Cromado	€ 240,00
.017	Cromo-Oro / Chrome-Gold / Chromé-Or / Chrom-Gold / Cromo-Oro	€ 314,00
.010	Oro / Gold / Doré / Gold / Oro	€ 269,00
.065	Bronzato / Bronze / Bronze / Bronze / Bronze	€ 317,00

## KA500601

 Kg 0,8  
Box pcs 4

Porta asciugamano in ottone.  
Brass towel holder.  
Porte serviette en laiton.  
Handtuchhalter aus Messing.  
Toallero de latón.

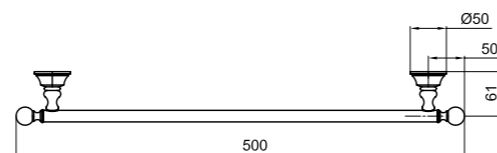

.015	Cromo / Chrome / Chromée / Verchromt / Cromado	€ 131,00
.017	Cromo-Oro / Chrome-Gold / Chromé-Or / Chrom-Gold / Cromo-Oro	€ 176,00
.010	Oro / Gold / Doré / Gold / Oro	€ 150,00
.065	Bronzato / Bronze / Bronze / Bronze / Bronze	€ 176,00

## KA500101

 Kg 0,6  
Box pcs 10

Portasapone in ottone.  
Soap holder in brass.  
Porte savon en laiton.  
Seifenschale mit Becher aus Messing.  
Jabonera de latón.

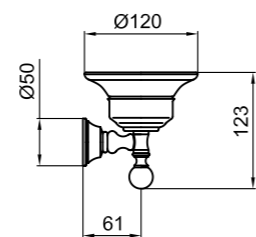

.015	Cromo / Chrome / Chromée / Verchromt / Cromado	€ 115,00
.017	Cromo-Oro / Chrome-Gold / Chromé-Or / Chrom-Gold / Cromo-Oro	€ 151,00
.010	Oro / Gold / Doré / Gold / Oro	€ 128,00
.065	Bronzato / Bronze / Bronze / Bronze / Bronze	€ 151,00

## KA500301

 Kg 0,6  
Box pcs 10

Portabicchiere in ottone.  
Tumbler holder in brass.  
Porte verre en laiton.  
Becherhalter aus Messing.  
Portavaso de latón.

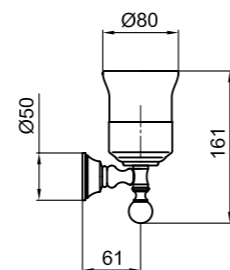

.015	Cromo / Chrome / Chromée / Verchromt / Cromado	€ 115,00
.017	Cromo-Oro / Chrome-Gold / Chromé-Or / Chrom-Gold / Cromo-Oro	€ 151,00
.010	Oro / Gold / Doré / Gold / Oro	€ 128,00
.065	Bronzato / Bronze / Bronze / Bronze / Bronze	€ 151,00

## KA500401

 Kg 0,3  
Box pcs 12

Appendino in ottone.  
Hook in brass.  
Peignoir en laiton.  
Haken aus Messing.  
Percha en latón.

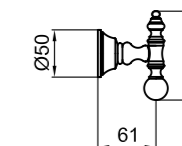

.015	Cromo / Chrome / Chromée / Verchromt / Cromado	€ 84,00
.017	Cromo-Oro / Chrome-Gold / Chromé-Or / Chrom-Gold / Cromo-Oro	€ 110,00
.010	Oro / Gold / Doré / Gold / Oro	€ 98,00
.065	Bronzato / Bronze / Bronze / Bronze / Bronze	€ 110,00

## KA501302

 Kg 1  
Box pcs 4

Porta scopino ovale in ottone a pavimento.  
Free standing brass oval-shaped toilet brush holder.  
Porte balai WC au sol ovale, en laiton.  
Oval WC-Bürstenständer aus Messing.  
Escobillero oval de suelo.

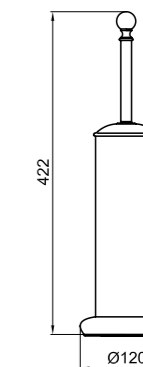

.015	Cromo / Chrome / Chromée / Verchromt / Cromado	€ 144,00
.017	Cromo-Oro / Chrome-Gold / Chromé-Or / Chrom-Gold / Cromo-Oro	€ 193,00
.010	Oro / Gold / Doré / Gold / Oro	€ 166,00
.065	Bronzato / Bronze / Bronze / Bronze / Bronze	€ 193,00

## KA501402

 Kg 0,7  
Box pcs 1

Porta asciugamano in ottone.  
Brass towel holder.  
Porte serviette en laiton.  
Handtuchhalter aus Messing.  
Toallero de latón.

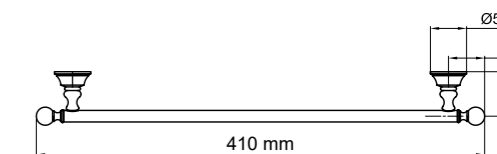

.015	Cromo / Chrome / Chromée / Verchromt / Cromado	€ 130,00
.010	Oro / Gold / Doré / Gold / Oro	€ 170,00
.065	Bronzato / Bronze / Bronze / Bronze / Bronze	€ 170,00

# DORIAN



DO700301.015  
Miscelatore lavabo.  
One hole basin mixer.

Classica, elegante, dall'inconfondibile sapore retrò. La collezione Dorian è un insieme di linee raffinate, volumi armonici e dettagli ricercati. La particolare forma della maniglia bianca in ceramica s'inserisce con eleganza in ogni suo elemento, valorizzando il fascino nostalgico di questo suggestivo design.

Classic, elegant, with an unmistakable retro flavour. The Dorian collection is a set of sophisticated lines, harmonious volumes and refined details. The particular shape of the white ceramic handle fits in elegantly in every element, enhancing the a nostalgic charm of this characteristic design.



DO860101.015  
Miscelatore vasca incasso.  
Concealed bath mixer.

## Finiture / finishes / finitions / ausföhrungen / acabados

.015	.010	.065
Cromo	Oro	Bronzato
Chrome	Gold	Bronze
Chromé	Doré	Bronze
Verchromt	Gold	Bronze
Cromado	Oro	Bronce



## DO700301

 Kg 2,3  
Box pcs 8



Monoforo monoblocco per lavabo con scarico 1"1/4 con flex inox cm 37 att. 3/8" F.

Monobloc washbasin mixer with 1"1/4 pop-up waste and 3/8" F flex. hoses cm 37.

Mélangeur de lavabo monotrou avec vidage automatique 1"1/4 et flexibles d'alimentation cm 37 3/8" F.

Waschtisch-Einlochbatterie mit Ablaufgarnitur 1" 1/4 und flex. Anschlussschläuchen cm. 37 3/8" F.

Grifo bimando para lavabo, desagüe 1"1/4, tubo flexible inoxidable de 37 cm y conexión 3/8" F.

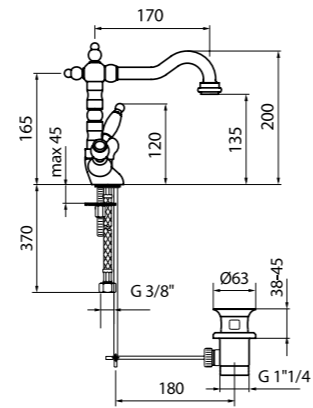

- .015 Cromo / Chrome / Chromée / Verchromt / Cromado € 189,00
- .010 Oro / Gold / Doré / Gold / Oro € 266,00
- .065 Bronzato / Bronze / Bronze / Bronze / Bronze € 255,00

 DO700302

 AC0757015  AC0331000 (DX)  
 AC0332000 (SX)

## DO750101

 Kg 3,2  
Box pcs 4



Batteria per lavabo a tre fori completa con scarico 1"1/4.

3-holes washbasin mixer with 1"1/4 pop-up waste.

Mélangeur de lavabo 3-trous bec fixe avec vidage automatique 1"1/4.

3-Loch-Waschtischbatterie mit Ablaufgarnitur 1" 1/4.

Grifo bimando para lavabo de repisa, 3 agujeros, desagüe 1"1/4.

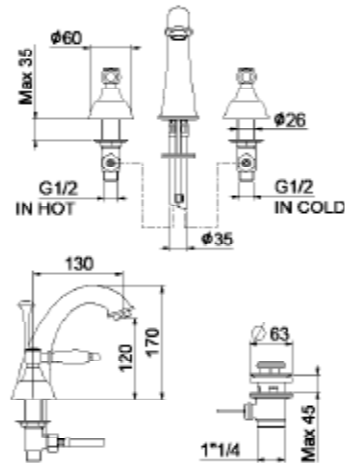

- .015 Cromo / Chrome / Chromée / Verchromt / Cromado € 251,00
- .010 Oro / Gold / Doré / Gold / Oro € 322,00
- .065 Bronzato / Bronze / Bronze / Bronze / Bronze € 316,00

 AC0462015  AC0331000 (DX)  
 AC0332000 (SX)

## DO750202

 Kg 3,4  
Box pcs 4



Batteria per lavabo a tre fori con bocca girevole, con scarico 1"1/4.

3-holes washbasin mixer swivel spout, with 1"1/4 pop-up waste.

Mélangeur de lavabo 3-trous bec mobile, avec vidage automatique 1"1/4.

3-Loch-Waschtischbatterie mit schwenkbarem Auslauf und Ablaufgarnitur 1" 1/4.

Grifo bimando para lavabo de repisa, 3 agujeros, con caño giratorio, desagüe 1"1/4.

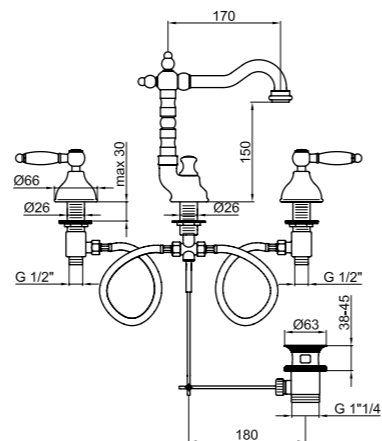

- .015 Cromo / Chrome / Chromée / Verchromt / Cromado € 305,00
- .010 Oro / Gold / Doré / Gold / Oro € 372,00
- .065 Bronzato / Bronze / Bronze / Bronze / Bronze € 357,00

 AC0757015  AC0331000 (DX)  
 AC0332000 (SX)

## DO710401

 Kg 2,2  
Box pcs 8



Monoforo monoblocco per bidet con scarico 1"1/4 con flex inox cm 37 att. 3/8" F.

Monobloc bidet mixer with 1"1/4 pop-up waste and 3/8" F flex. hoses cm 37.

Mélangeur de bidet monotrou avec vidage automatique 1"1/4 et flexibles d'alimentation cm 37 3/8" F.

Bidet-Einlochbatterie mit Ablaufgarnitur 1" 1/4 und flex Anschlussschläuchen cm. 37 3/8" F.

Grifo bimando para bidé, desagüe 1"1/4, tubo flexible inoxidable de 37 cm y conexión 3/8" F.

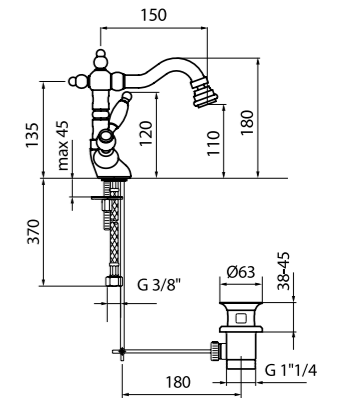

- .015 Cromo / Chrome / Chromée / Verchromt / Cromado € 189,00
- .010 Oro / Gold / Doré / Gold / Oro € 266,00
- .065 Bronzato / Bronze / Bronze / Bronze / Bronze € 255,00

 DO710102

 AC0758015  AC0331000 (DX)  
 AC0332000 (SX)

## DO710202

 Kg 3,4  
Box pcs 4



Batteria per bidet a tre fori completa con scarico 1"1/4.

3-holes bidet mixer with 1"1/4 pop-up waste.

Mélangeur de bidet 3-trous avec vidage automatique 1"1/4.

3-Loch Bidetbatterie mit Ablaufgarnitur 1" 1/4.

Grifo bimando para bidé de repisa, 3 agujeros, desagüe 1"1/4.

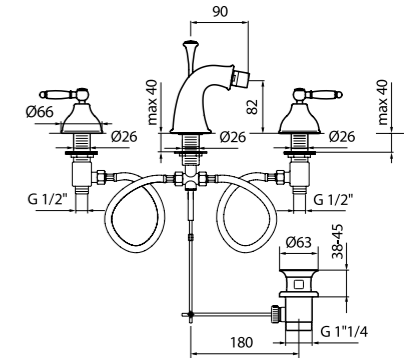

- .015 Cromo / Chrome / Chromée / Verchromt / Cromado € 245,00
- .010 Oro / Gold / Doré / Gold / Oro € 316,00
- .065 Bronzato / Bronze / Bronze / Bronze / Bronze € 311,00

 AC0465015  AC0331000 (DX)  
 AC0332000 (SX)

## DO710502

 Kg 3,6  
Box pcs 4



Batteria per bidet a tre fori con bocca girevole, con scarico 1"1/4.

3-holes bidet mixer swivel spout with 1"1/4 pop-up waste.

Mélangeur de bidet 3-trous bec mobile avec vidage automatique 1"1/4.

3-Loch-Bidetbatterie mit schwenkbarem Auslauf und Ablaufgarnitur 1" 1/4.

Grifo bimando para bidé de repisa, 3 agujeros, con caño giratorio, desagüe 1"1/4.

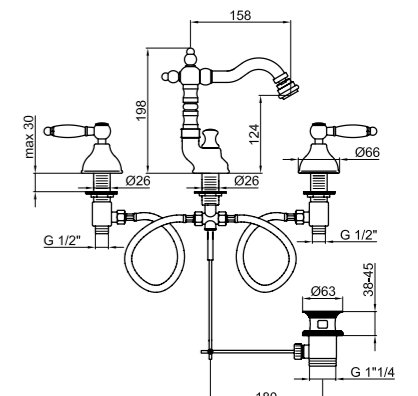

- .015 Cromo / Chrome / Chromée / Verchromt / Cromado € 295,00
- .010 Oro / Gold / Doré / Gold / Oro € 360,00
- .065 Bronzato / Bronze / Bronze / Bronze / Bronze € 346,00

 AC0758015  AC0331000 (DX)  
 AC0332000 (SX)

## DO750404

 Kg 2  
Box pcs 12



Batteria per lavabo a 3 fori incasso muro.

Concealed 3-holes washbasin mixer.

Mélangeur de lavabo 3 trous à encastrer.

Unterputz - 3-Loch-Waschtischbatterie.

Grifo empotrable de pared para lavabo, 3 agujeros.

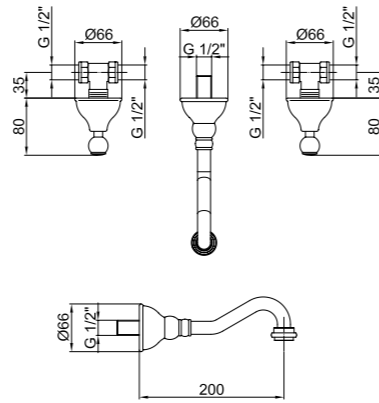

.015	Cromo / Chrome / Chromée / Verchromt / Cromado	€ 284,00
.010	Oro / Gold / Doré / Gold / Oro	€ 355,00
.065	Bronzato / Bronze / Bronze / Bronze / Bronze	€ 322,00

 AC0757015  AC0331000 (DX)  
AC0332000 (SX)

## DO720201

 Kg 3,6  
Box pcs 6



Gruppo per vasca esterno completo con flessibile in ottone da 150 cm, doccetta monogetto.

Bath mixer with shower set complete of brass hose 150 cm and monospray handshower.



Mélangeur bain-douche complet de flexible en laiton 150 cm et douchette monojet.

Badebatterie mit Brausegarnitur bestehend aus Metall-Brauseschlauch 150 cm. und Mono-Wasserstrahl Handbrause.

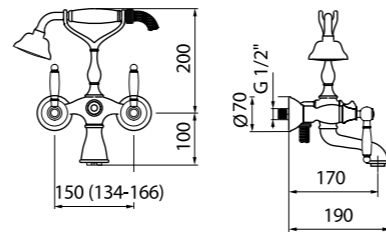
Grupo externo para bañera, con tubo flexible de latón, flexible 150 cm y ducha.



.015	Cromo / Chrome / Chromée / Verchromt / Cromado	€ 362,00
.010	Oro / Gold / Doré / Gold / Oro	€ 491,00
.065	Bronzato / Bronze / Bronze / Bronze / Bronze	€ 459,00

 AC0829015  AC0331000 (DX)  
AC0332000 (SX)

## DO730101

 Kg 3,1  
Box pcs 3



Gruppo per bordo vasca 5 fori completo con flessibile in ottone da 150 cm e doccetta monogetto.

5-holes deck mounted bath mixer complete of brass hose 150 cm and monospray handshower.

Mélangeur bain-douche 5-trous, flexible en laiton 150 cm et douchette monojet.

5-Loch-Wannenrandarmatur mit Metallbrauseschlauch 150 cm. und Mono-Wasserstrahl Handbrause.

Grupo para borde de bañera, 5 agujeros, con tubo flexible de latón, longitud 150 cm y ducha.

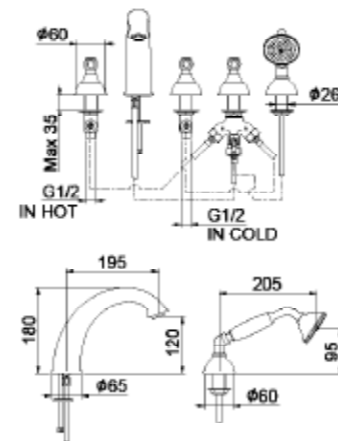

.015	Cromo / Chrome / Chromée / Verchromt / Cromado	€ 435,00
.010	Oro / Gold / Doré / Gold / Oro	€ 535,00
.065	Bronzato / Bronze / Bronze / Bronze / Bronze	€ 522,00

 AC0463015  AC0331000 (DX)  
AC0332000 (SX)

Diametro foratura pannello vasca A-B-C-D = 28 mm  
Massimo spessore pannello vasca 35 mm

Diameter of the bath deck drilling A-B-C-D = 28 mm  
Largest thickness of the bath deck 35 mm

Diamètre perçage du bord de la baignoire A-B-C-D = 28 mm  
Maximum épaisseur du bord de la baignoire 35 mm

Bohrungsdurchmesser der Wannenrandarmatur A-B-C-D = 28 mm  
Grösste Dicke der Wannenrandarmatur 35 mm

Diámetro agujero borde de bañera A-B-C-D = 28 mm  
Máximo espesor borde de bañera 35 mm

## DO720801

 Kg 2  
Box pcs 9,8



Gruppo per vasca esterno con bocca integrale, con colonne a pavimento, flessibile e doccetta monogetto.

Bath mixer with floor connections and monospray shower set.

Mélangeur bain/douche avec raccords sur pieds et garniture de douche monojet.

Badebatterie mit Standverschraubungen und Mono-Wasserstrahl Brausegarnitur.

Grupo externo para bañera, con columnas de toma de agua de suelo.

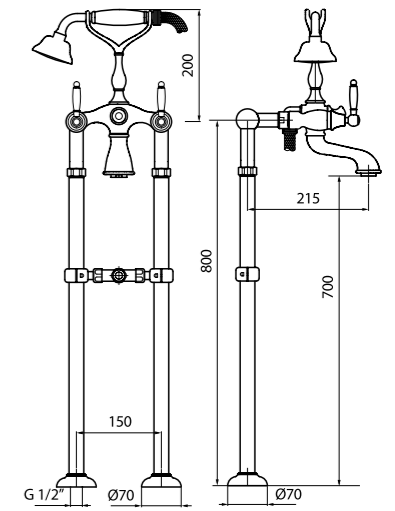

.015	Cromo / Chrome / Chromée / Verchromt / Cromado	€ 887,00
.010	Oro / Gold / Doré / Gold / Oro	€ 1.026,00
.065	Bronzato / Bronze / Bronze / Bronze / Bronze	€ 1.003,00

 AC0829015  AC0331000 (DX)  
AC0463015 AC0332000 (SX)

## DO721208

 Kg 4,3  
Box pcs 1

 Kg 3,6  
Box pcs 1



Miscelatore monocomando per vasca esterno, versione completa di colonna, soffione e doccetta monogetto.

Bath mixer with column, shower head and monospray handshower.

Mélangeur debain/douche avec colonne, pomme de douche et douchette monojet.

Badebatterie mit Brausegleitstange, Brausekopf und 1 Funktion Handbrause.

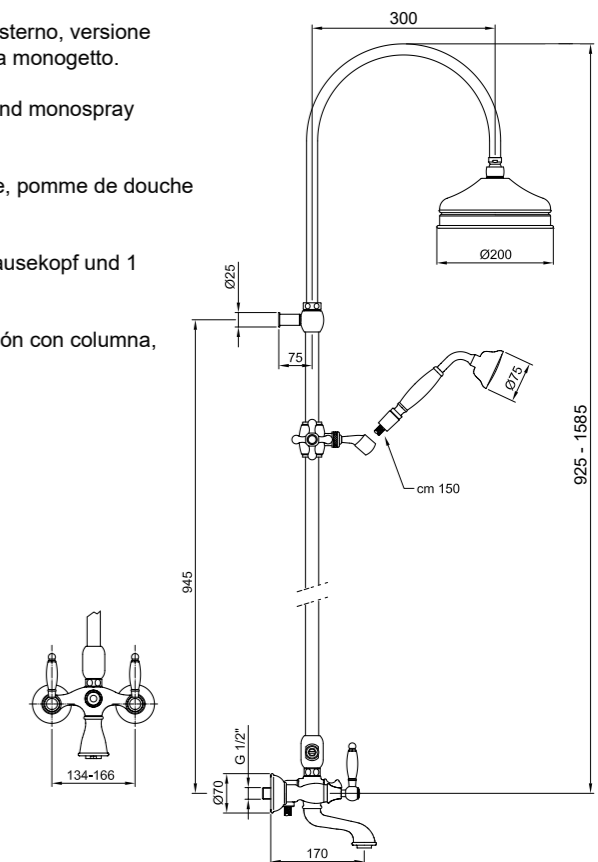

Monomando externo para bañera, versión con columna, rociador y ducha.



.015	Cromo / Chrome / Chromée / Verchromt / Cromado	€ 767,00
.010	Oro / Gold / Doré / Gold / Oro	€ 1.200,00
.065	Bronzato / Bronze / Bronze / Bronze / Bronze	€ 1.104,00

 AC0829015  AC0331000 (DX)  
AC0463015 AC0332000 (SX)

## DO760101

 Kg 2,9  
 Box pcs 12

Gruppo per doccia esterno completo con flessibile in ottone da 150 cm, doccetta e gancio di supporto.

Shower mixer with shower set complete of brass hose 150 cm, handshower and holder.



Mélangeur de douche complet de flexible en laiton 150 cm, douchette et support mural.

Brausebatterie mit Brausegarnitur bestehend aus Metall-Brauseschlauch 150 cm, Handbrause und Wandhalterung.

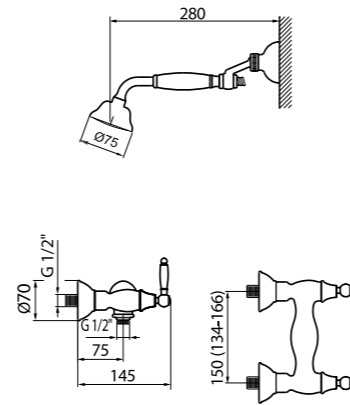
Grupo externo para ducha, con tubo flexible de latón, flexible 150 cm; rociador y soporte.



- |      |  |          |
|------|--|----------|
| .015 | Cromo / Chrome / Chromée / Verchromt / Cromado | € 263,00 |
| .010 | Oro / Gold / Doré / Gold / Oro                 | € 353,00 |
| .065 | Bronzato / Bronze / Bronze / Bronze / Bronze   | € 319,00 |

 AC0331000 (DX)  
 AC0332000 (SX)

 + € 15,00

## DO760405

 Kg 4,3  
 Box pcs 1

 Kg 2,9  
 Box pcs 1

Gruppo doccia esterno, versione completa di colonna, soffione e doccetta monogetto.

Shower mixer with shower column, shower head and mono-spray handshower.

Mélangeur de douche avec colonne, pomme de douche et garniture de douche mono-jet.

Brausebatterie mit Gleitstange, Kopfbrause und Mono-Wasserstrahe Handbrause.

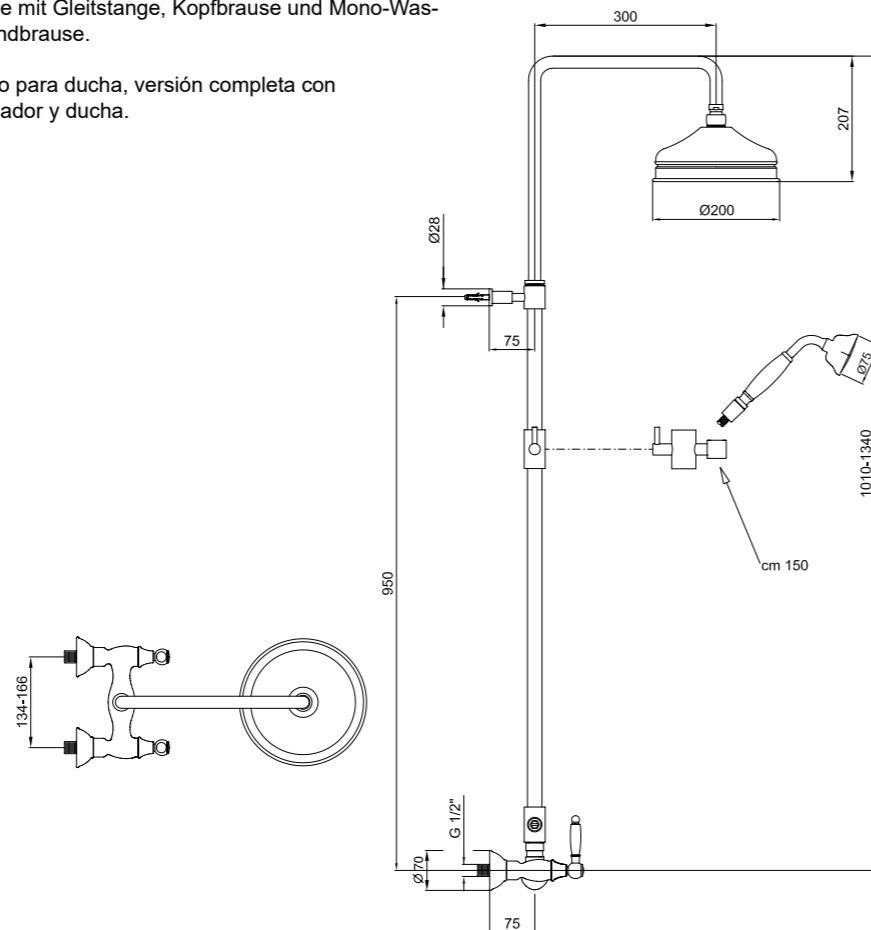

Grupo externo para ducha, versión completa con columna, rociador y ducha.



- |      |  |            |
|------|--|------------|
| .015 | Cromo / Chrome / Chromée / Verchromt / Cromado | € 627,00   |
| .010 | Oro / Gold / Doré / Gold / Oro                 | € 1.038,00 |
| .065 | Bronzato / Bronze / Bronze / Bronze / Bronze   | € 1.016,00 |

 AC0331000 (DX)  
 AC0332000 (SX)

## DO880101

 Kg 1,2  
 Box pcs 12

Miscelatore monocomando per doccia incasso, con piastra, senza flessibile, doccetta e gancio.

Concealed single lever shower mixer with cover plate, without shower set.

Mitigeur de douche à encastrer avec rosace, sans garniture de douche.

Einhebelmischer Unterputz-Brausebatterie, mit Rosette ohne Brausegarnitur.

Monomando empotrable para ducha, con placa, sin tubo flexible, ducha ni gancho.

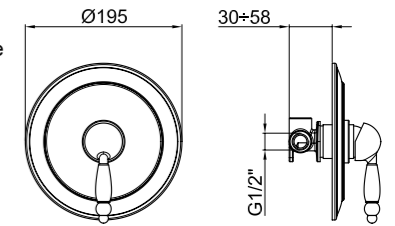



- |      |  |          |
|------|--|----------|
| .015 | Cromo / Chrome / Chromée / Verchromt / Cromado | € 155,00 |
| .010 | Oro / Gold / Doré / Gold / Oro                 | € 198,00 |
| .065 | Bronzato / Bronze / Bronze / Bronze / Bronze   | € 188,00 |

 AC0691015

 AC0833015  Ø 35 mm  
AC0338000

## DO860101

 Kg 1,9  
 Box pcs 12

Miscelatore monocomando per vasca incasso; con deviatore automatico; senza flessibile, doccetta e gancio di supporto.

Concealed single lever bath mixer with automatic diverter, without shower set.

Mitigeur bain-douche à encastrer avec inverseur automatique, sans garniture de douche.

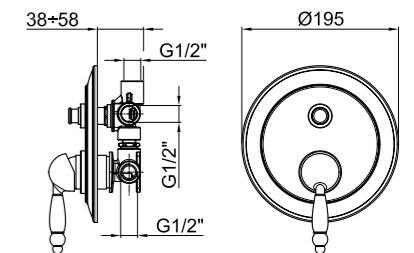

Einhebelmischer Unterputz-Badebatterie mit Umstellung, ohne Brausegarnitur.

Monomando empotrable para bañera, con desviador automático; sin tubo flexible, ducha ni soporte.



- |      |  |          |
|------|--|----------|
| .015 | Cromo / Chrome / Chromée / Verchromt / Cromado | € 231,00 |
| .010 | Oro / Gold / Doré / Gold / Oro                 | € 274,00 |
| .065 | Bronzato / Bronze / Bronze / Bronze / Bronze   | € 264,00 |

 AC0691015

 AC0834015  Ø 35 mm  
AC0338000

# ACCESSORI *bagno*

## *Tondi-Round*

CHAMPAGNE



**ACB210.325**  
Porta dosatore sapone liquido.  
Wall mounted liquid soap dispenser.



**ACB130.325**  
Porta bicchiere a parete.  
Wall mounted tumbler.



**ACB400.325**  
Porta asciugamani.  
Towel holder.

## *Quadrati-Square*

GLICINE



**ACC601.220**  
Appendino.  
Hook.



**ACC211.220**  
Porta dosatore sapone liquido a parete.  
Wall mounted liquid soap dispenser.



**ACC011.220**  
Porta sapone.  
Wall mounted soap dish.



**ACC400.220**  
Porta asciugamano.  
Towel holder.

NICKEL



**LV500501.355**  
Appendino.  
Hook.



**LV500301.355**  
Porta bicchiere a parete.  
Wall mounted tumbler.



**LV500201.355**  
Porta dosatore sapone liquido.  
Wall mounted liquid soap dispenser.



**LV500501.355**  
Porta asciugamani.  
Towel holder.

BLU NOTTE



**LV500501.260**  
Appendino.  
Hook.



**LV500301.260**  
Porta bicchiere a parete.  
Wall mounted tumbler.



**LV500201.260**  
Porta dosatore sapone liquido.  
Wall mounted liquid soap dispenser.



**LV500501.260**  
Porta asciugamani.  
Towel holder.

**ACC011**

Porta sapone in ceramica.  
 Soap holder in ceramic.  
 Porte-savon en céramique.  
 Seifenschale aus Keramik.

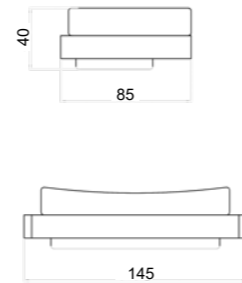

- .015 Cromo / Chrome / Chromée / Verchromt / Cromado € 95,00
- .560 Nero opaco / Matt black / Noir mat / Matt Schwarz / Negro mate € 133,00
- .740 Bianco opaco / Matt white / Blanc mat / Matt Weiss / Blanco mate € 133,00
- Collezione Primavera € 152,00

*Quadrato - Square***ACC400**

Porta salvietta 30 cm.  
 Towel rail 30 cm.  
 Porte-serviette 30 cm.  
 Handtuchhalter aus Messing.

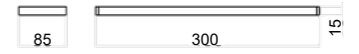

- .015 Cromo / Chrome / Chromée / Verchromt / Cromado € 78,00
- .560 Nero opaco / Matt black / Noir mat / Matt Schwarz / Negro mate € 109,00
- .740 Bianco opaco / Matt white / Blanc mat / Matt Weiss / Blanco mate € 109,00
- Collezione Primavera € 125,00

**ACC211**

Dispenser sapone liquido in ceramica.  
 Liquid soap dispenser holder in ceramic.  
 Porte-diffuseur de savon en céramique.  
 Seifenspender aus Keramik.

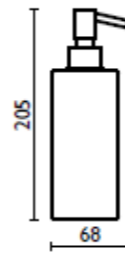

- .015 Cromo / Chrome / Chromée / Verchromt / Cromado € 128,00
- .560 Nero opaco / Matt black / Noir mat / Matt Schwarz / Negro mate € 180,00
- .740 Bianco opaco / Matt white / Blanc mat / Matt Weiss / Blanco mate € 180,00
- Collezione Primavera € 205,00

**ACC520**

Porta rotolo.  
 Toilet roll holder.  
 Porte-papier.  
 Toilettenpapierhalter aus Messing.

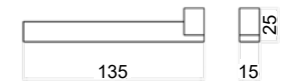

- .015 Cromo / Chrome / Chromée / Verchromt / Cromado € 59,00
- .560 Nero opaco / Matt black / Noir mat / Matt Schwarz / Negro mate € 83,00
- .740 Bianco opaco / Matt white / Blanc mat / Matt Weiss / Blanco mate € 83,00
- Collezione Primavera € 95,00

**ACC111**

Porta bicchiere in ceramica.  
 Tumbler holder in ceramic.  
 Porte-verre en céramique.  
 Becherhalter aus Keramik.

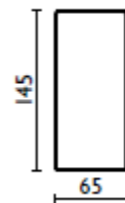

- Ceramica / Ceramic / Céramique / Keramik € 94,00

**ACC601**

Appendino.  
 Hook.  
 Porte-peignoir.  
 Haken aus Messing.



- .015 Cromo / Chrome / Chromée / Verchromt / Cromado € 50,00
- .560 Nero opaco / Matt black / Noir mat / Matt Schwarz / Negro mate € 70,00
- .740 Bianco opaco / Matt white / Blanc mat / Matt Weiss / Blanco mate € 70,00
- Collezione Primavera € 80,00

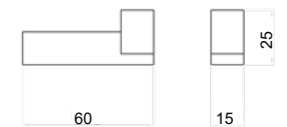

**ACC011**

Porta scopino d'appoggio in ceramica.  
Standing toilet brush holder in ceramic.  
Porte-balai à poser en céramique.  
WC-Bürstenständer aus Messing.

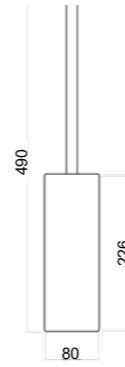

.015	Cromo / Chrome / Chromée / Verchromt / Cromado	€ 122,00
.560	Nero opaco / Matt black / Noir mat / Matt Schwarz / Negro mate	€ 171,00
.740	Bianco opaco / Matt white / Blanc mat / Matt Weiss / Blanco mate	€ 171,00
	Collezione Primavera	€ 195,00

**ACB210**

Dispenser sapone liquido in vetro satinato.  
Liquid soap dispenser holder in frosted glass.  
Porte-diffuseur de savon en verre dépoli.  
Seifenspender.

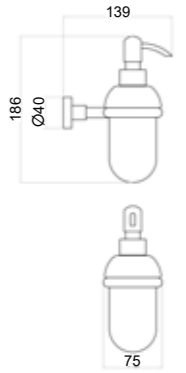

.015	Cromo / Chrome / Chromée / Verchromt / Cromado	€ 81,00
.560	Nero opaco / Matt black / Noir mat / Matt Schwarz / Negro mate	€ 114,00
.740	Bianco opaco / Matt white / Blanc mat / Matt Weiss / Blanco mate	€ 114,00
	Collezione Primavera	€ 130,00

**ACB010**

Porta sapone in vetro satinato.  
Soap holder in frosted glass.  
Porte-savon en verre dépoli.  
Seifenschale.



*Fonoli - Round*

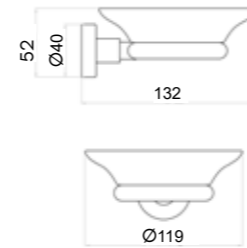

.015	Cromo / Chrome / Chromée / Verchromt / Cromado	€ 43,00
.560	Nero opaco / Matt black / Noir mat / Matt Schwarz / Negro mate	€ 60,00
.740	Bianco opaco / Matt white / Blanc mat / Matt Weiss / Blanco mate	€ 60,00
	Collezione Primavera	€ 68,00

**ACB130**

Porta bicchiere in vetro satinato.  
Tumbler holder in frosted glass.  
Porte-verre en verre dépoli.  
Becherhalter.

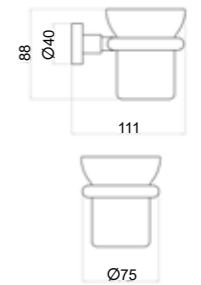

.015	Cromo / Chrome / Chromée / Verchromt / Cromado	€ 43,00
.560	Nero opaco / Matt black / Noir mat / Matt Schwarz / Negro mate	€ 60,00
.740	Bianco opaco / Matt white / Blanc mat / Matt Weiss / Blanco mate	€ 60,00
	Collezione Primavera	€ 68,00

**ACB015**

Porta sapone in ottone.  
Soap holder in brass.  
Porte-savon en laiton.  
Seifenschale.

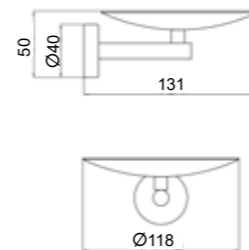

.015	Cromo / Chrome / Chromée / Verchromt / Cromado	€ 64,00
.560	Nero opaco / Matt black / Noir mat / Matt Schwarz / Negro mate	€ 90,00
.740	Bianco opaco / Matt white / Blanc mat / Matt Weiss / Blanco mate	€ 90,00
	Collezione Primavera	€ 103,00

**ACB400**

Porta salvietta 30 cm.  
Towel rail 30 cm.  
Porte-serviette 30 cm.  
Handtuchhalter 30 cm.



.015	Cromo / Chrome / Chromée / Verchromt / Cromado	€ 51,00
.560	Nero opaco / Matt black / Noir mat / Matt Schwarz / Negro mate	€ 72,00
.740	Bianco opaco / Matt white / Blanc mat / Matt Weiss / Blanco mate	€ 72,00
	Collezione Primavera	€ 82,00

## ACB450

Porta salvietta ad anello.

Towel ring.

Anneau porte-serviette.

Handtuchhalter.

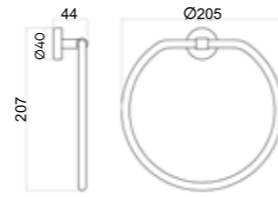

.015	Cromo / Chrome / Chromée / Verchromt / Cromado	€ 71,00
.560	Nero opaco / Matt black / Noir mat / Matt Schwarz / Negro mate	€ 99,00
.740	Bianco opaco / Matt white / Blanc mat / Matt Weiss / Blanco mate	€ 99,00
	Collezione Primavera	€ 114,00

## ACC011

Appendino.

Hook.

Porte-peignoir.

Haken.

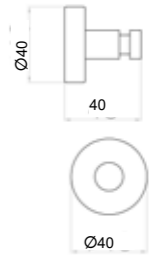

.015	Cromo / Chrome / Chromée / Verchromt / Cromado	€ 17,00
.560	Nero opaco / Mat black / Noir mat / Matt Schwarz / Negro mate	€ 24,00
.740	Bianco opaco / Matt white / Blanc mat / Matt Weiss / Blanco mate	€ 24,00
	Collezione Primavera	€ 27,00

## ACB510

Porta rotolo.

Toilet roll holder.

Porte-papier.

Toilettenpapierhalter.

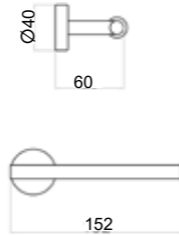

.015	Cromo / Chrome / Chromée / Verchromt / Cromado	€ 34,00
.560	Nero opaco / Matt black / Noir mat / Matt Schwarz / Negro mate	€ 48,00
.740	Bianco opaco / Matt white / Blanc mat / Matt Weiss / Blanco mate	€ 48,00
	Collezione Primavera	€ 54,00

## ACB010

Porta scopino a terra d'appoggio in ottone.

Standing toilet brush holder in brass.

Porte-balai à poser en laiton.

WC-Bürstenständer

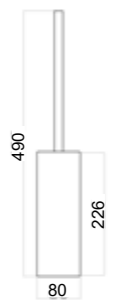

.015	Cromo / Chrome / Chromée / Verchromt / Cromado	€ 103,00
.560	Nero opaco / Matt black / Noir mat / Matt Schwarz / Negro mate	€ 144,00
.740	Bianco opaco / Matt white / Blanc mat / Matt Weiss / Blanco mate	€ 144,00
	Collezione Primavera	€ 165,00

## ACB601

Appendino.

Hook.

Porte-peignoir.

Haken.

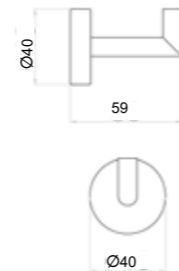

.015	Cromo / Chrome / Chromée / Verchromt / Cromado	€ 19,00
.560	Nero opaco / Matt black / Noir mat / Matt Schwarz / Negro mate	€ 27,00
.740	Bianco opaco / Matt white / Blanc mat / Matt Weiss / Blanco mate	€ 27,00
	Collezione Primavera	€ 30,00

**LV500501**Kg 0,8  
Box pcs 4

Porta asciugamano in ottone.

Brass towel holder.

Porte serviette en laiton.

Handtuchhalter aus Messing.

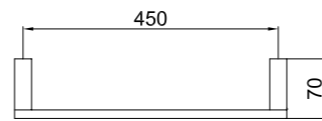
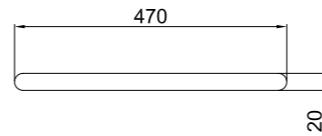

- |                        |  |          |
|------------------------|--|----------|
| .015                   | Cromo / Chrome / Chromée / Verchromt / Cromado   | € 180,00 |
| .560                   | Nero opaco / Matt black / Noir mat / Matt Schwarz / Negro mate                         | € 252,00 |
| .345                   | Acciaio spazzolato / Brushed nickel / Acier brossé / Edelstahl Optik / Acero cepillado | € 288,00 |
| ■ Collezione Primavera |  | € 288,00 |

**LV500201**Kg 1,5  
Box pcs 10

Porta dosatore sapone liquido a parete in ceramica con pompetta in metallo.

Wall mounted ceramic liquid soap dispenser.

Distributeur de savon liquide à mur en céramique

Wand Seifenspender aus Keramik.

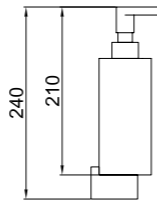
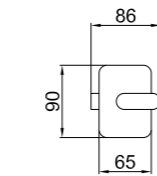

- |                        |  |          |
|------------------------|--|----------|
| .015                   | Cromo / Chrome / Chromée / Verchromt / Cromado   | € 240,00 |
| .560                   | Nero opaco / Matt black / Noir mat / Matt Schwarz / Negro mate                         | € 336,00 |
| .345                   | Acciaio spazzolato / Brushed nickel / Acier brossé / Edelstahl Optik / Acero cepillado | € 384,00 |
| ■ Collezione Primavera |  | € 384,00 |

**LV500101**Kg 1,6  
Box pcs 10

Porta sapone a parete in ceramica.

Wall mounted ceramic soap dish.

Porte savon à mur en céramique.

Seifenschale aus Keramik.

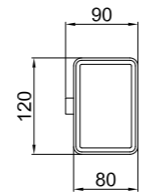
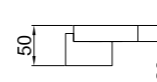

- |                        |  |          |
|------------------------|--|----------|
| .015                   | Cromo / Chrome / Chromée / Verchromt / Cromado   | € 94,00  |
| .560                   | Nero opaco / Matt black / Noir mat / Matt Schwarz / Negro mate                         | € 132,00 |
| .345                   | Acciaio spazzolato / Brushed nickel / Acier brossé / Edelstahl Optik / Acero cepillado | € 150,00 |
| ■ Collezione Primavera |  | € 150,00 |

**LV500301**Kg 1  
Box pcs 10

Porta bicchiere in ceramica a parete.

Wall mounted ceramic tumbler.

Porte verre en céramique à mur.

Wand Becherhalter aus Keramik.

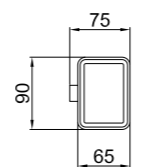
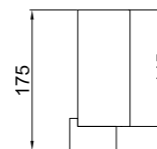

- |                        |  |          |
|------------------------|--|----------|
| .015                   | Cromo / Chrome / Chromée / Verchromt / Cromado   | € 100,00 |
| .560                   | Nero opaco / Matt black / Noir mat / Matt Schwarz / Negro mate                         | € 140,00 |
| .345                   | Acciaio spazzolato / Brushed nickel / Acier brossé / Edelstahl Optik / Acero cepillado | € 160,00 |
| ■ Collezione Primavera |  | € 160,00 |

**LV501501**Kg 1,5  
Box pcs 10Porta dosatore sapone liquido a parete con porta asciugamano.  
Wall mounted ceramic liquid soap dispenser with towel holder.  
Distributeur de savon liquide à mur en céramique avec porte serviette.  
Seifenspender aus Keramik mit Handtuchhalter.

- |                        |  |          |
|------------------------|--|----------|
| .015                   | Cromo / Chrome / Chromée / Verchromt / Cromado   | € 300,00 |
| .560                   | Nero opaco / Matt black / Noir mat / Matt Schwarz / Negro mate                         | € 420,00 |
| .345                   | Acciaio spazzolato / Brushed nickel / Acier brossé / Edelstahl Optik / Acero cepillado | € 480,00 |
| ■ Collezione Primavera |  | € 480,00 |

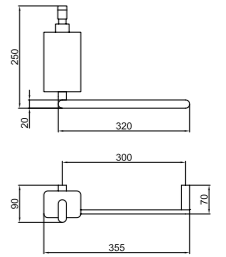
**LV501601**Kg 1,5  
Box pcs 10Porta sapone a parete in ceramica con porta asciugamano.  
Wall mounted ceramic soap dish with towel holder.  
Porte savon à mur en céramique avec porte serviette.  
Seifenschale aus Keramik mit Handtuchhalter.

- |                        |  |          |
|------------------------|--|----------|
| .015                   | Cromo / Chrome / Chromée / Verchromt / Cromado   | € 216,00 |
| .560                   | Nero opaco / Matt black / Noir mat / Matt Schwarz / Negro mate                         | € 287,00 |
| .345                   | Acciaio spazzolato / Brushed nickel / Acier brossé / Edelstahl Optik / Acero cepillado | € 302,00 |
| ■ Collezione Primavera |  | € 302,00 |

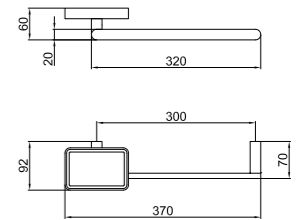
**LV500801**Kg 0,9  
Box pcs 10Porta rotolo.  
Toilet roll holder.  
Support en laiton pour papier rouleaux.  
Toilettenpapierhalter.

- |                        |  |         |
|------------------------|--|---------|
| .015                   | Cromo / Chrome / Chromée / Verchromt / Cromado   | € 50,00 |
| .560                   | Nero opaco / Matt black / Noir mat / Matt Schwarz / Negro mate                         | € 70,00 |
| .345                   | Acciaio spazzolato / Brushed nickel / Acier brossé / Edelstahl Optik / Acero cepillado | € 80,00 |
| ■ Collezione Primavera |  | € 80,00 |

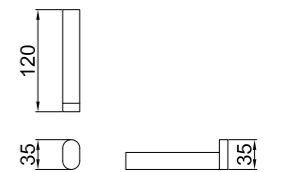
**LV500401**Kg 0,5  
Box pcs 10Appendino in ottone.  
Hook in brass.  
Peignoir en laiton.  
Haken aus Messing.

- |                        |  |         |
|------------------------|--|---------|
| .015                   | Cromo / Chrome / Chromée / Verchromt / Cromado   | € 43,00 |
| .560                   | Nero opaco / Matt black / Noir mat / Matt Schwarz / Negro mate                         | € 60,00 |
| .345                   | Acciaio spazzolato / Brushed nickel / Acier brossé / Edelstahl Optik / Acero cepillado | € 69,00 |
| ■ Collezione Primavera |  | € 69,00 |

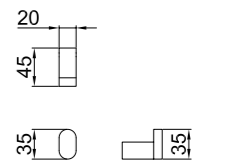
**LV501301**Kg 1,2  
Box pcs 2Porta scopino a parete.  
Wall mounted toilet brush holder.  
Porte balai WC mural.  
Wand WC Bürste.

- |                        |  |          |
|------------------------|--|----------|
| .015                   | Cromo / Chrome / Chromée / Verchromt / Cromado   | € 190,00 |
| .560                   | Nero opaco / Matt black / Noir mat / Matt Schwarz / Negro mate                         | € 266,00 |
| .345                   | Acciaio spazzolato / Brushed nickel / Acier brossé / Edelstahl Optik / Acero cepillado | € 304,00 |
| ■ Collezione Primavera |  | € 304,00 |

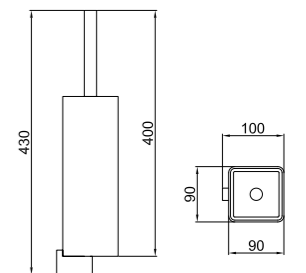



*easy*  
BATHROOM

# EASY K-BOX

NUOVO DOCCIA INCASSO

NEW BUILT-IN BODY

BENVENUTI NELL'ERA DELL'IDRAULICA SENZA LIMITI!

WELCOME TO THE AGE OF PLUMBING WITHOUT LIMITS!

Il nostro nuovo progetto sui corpi incasso è un'ottima soluzione per chi desidera combinare funzionalità, estetica e flessibilità. Un nuovo modo di vedere e di vivere la progettazione dell'ambiente bagno per quanto riguarda miscelatori da incasso lavabo e doccia, che offre la libertà di decidere senza limiti.

La possibilità di installazione solo del corpo incasso facilita sia il lavoro dell'idraulico, il quale può procedere senza le parti esterne, sia il cliente che ha tutto il tempo di decidere comodamente design e finitura per rispettare lo stile del bagno.

Our new design on concealed bodies is an excellent solution for those who wish to combine functionality, aesthetics and flexibility. A new way of looking at and experiencing bathroom design with regard to concealed basin and shower mixers, which offers the freedom to decide without limits.

The possibility of installing only the built-in body facilitates both the work of the plumber, who can proceed without the external parts, as well as the customer who has plenty of time to comfortably decide on the design and finish to match the style of the bathroom.

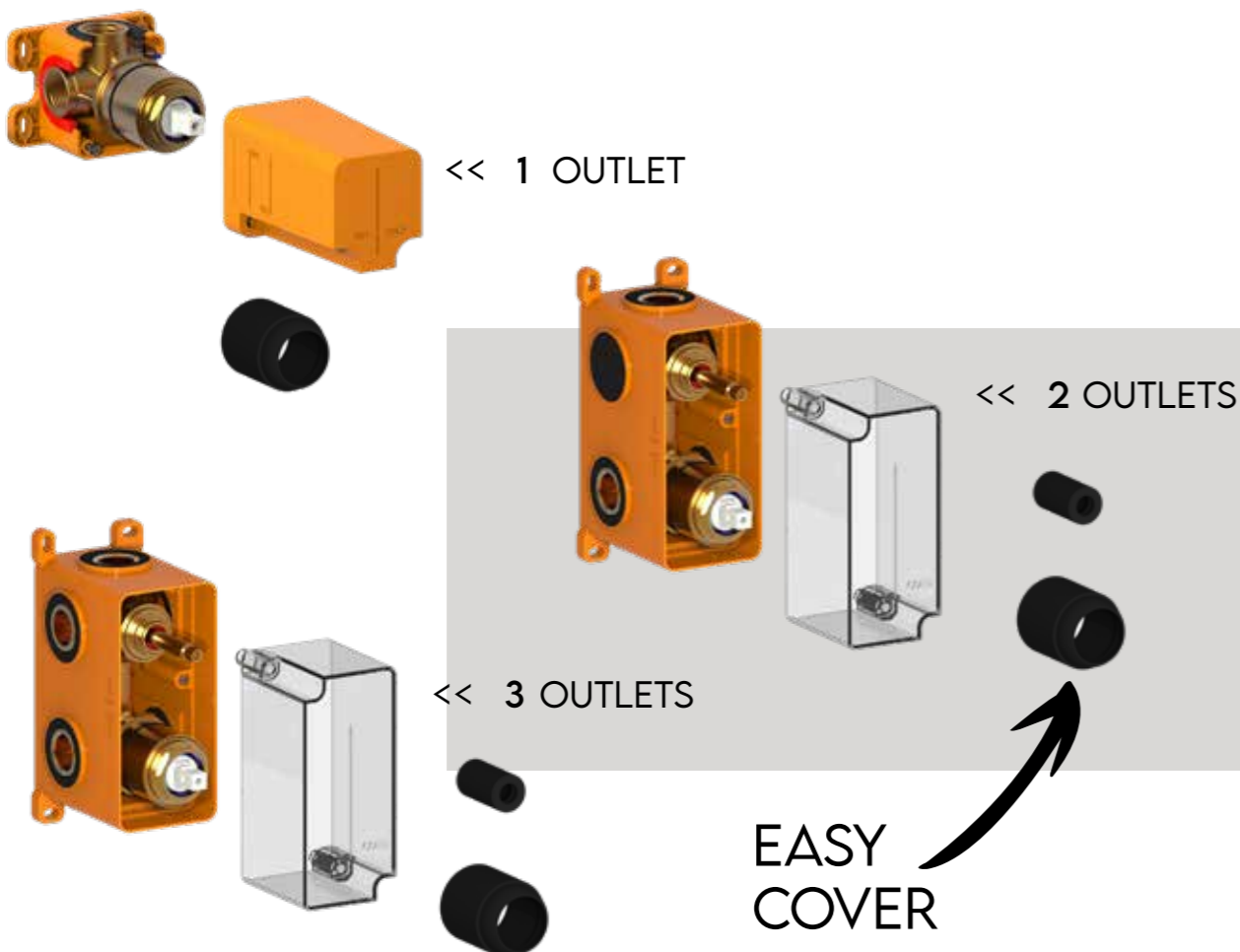

## I VANTAGGI

- Estetica Pulita: Le parti interne sono nascoste, lasciando una superficie esterna minima e ordinata.
- Manutenzione semplice: Le parti esterne intercambiabili consentono una manutenzione e un aggiornamento più semplici, senza dover smontare l'intera unità.
- Flessibilità di design: puoi cambiare l'aspetto della tua doccia con facilità, aggiornando solo le parti esterne per adattare a nuove tendenze o cambiamenti di arredamento.

## THE ADVANTAGES

- Clean aesthetics: Internal parts are hidden, leaving a minimal, neat external surface.
- Simple maintenance: Interchangeable external parts allow easier changes and maintenance, without having to dismantle the entire unit.
- Flexible design: you can easily change your shower look, replacing only the external parts to suit new trends or changes in décor.

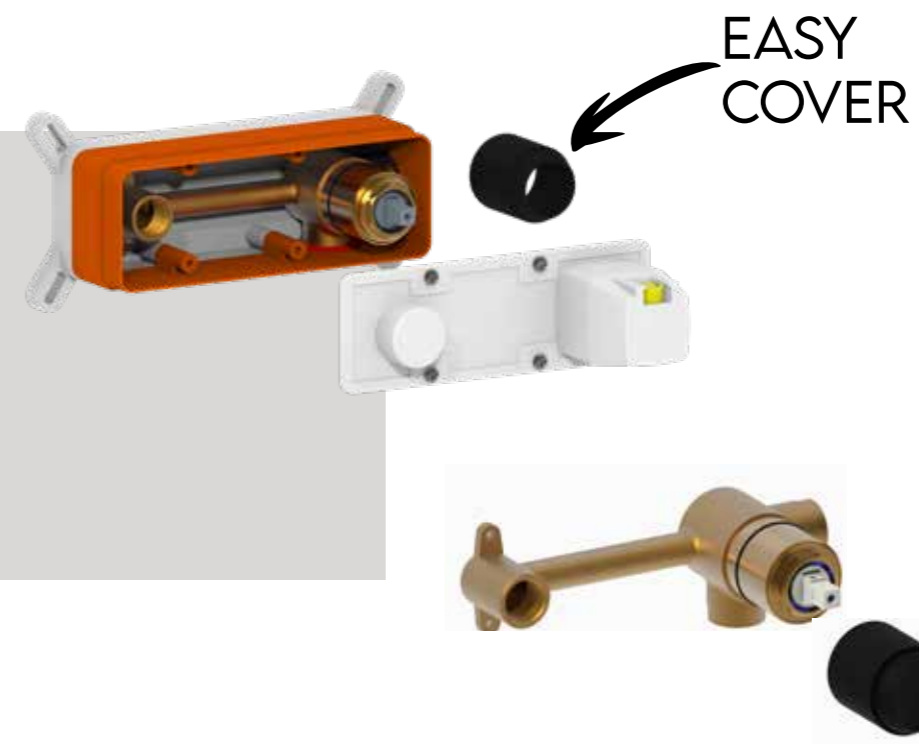

SCAN FOR VIDEO

# EASY K-BOX

NUOVO DOCCIA INCASSO

NEW BUILT-IN BODY

MODELLO STANDARD

STANDARD MODEL

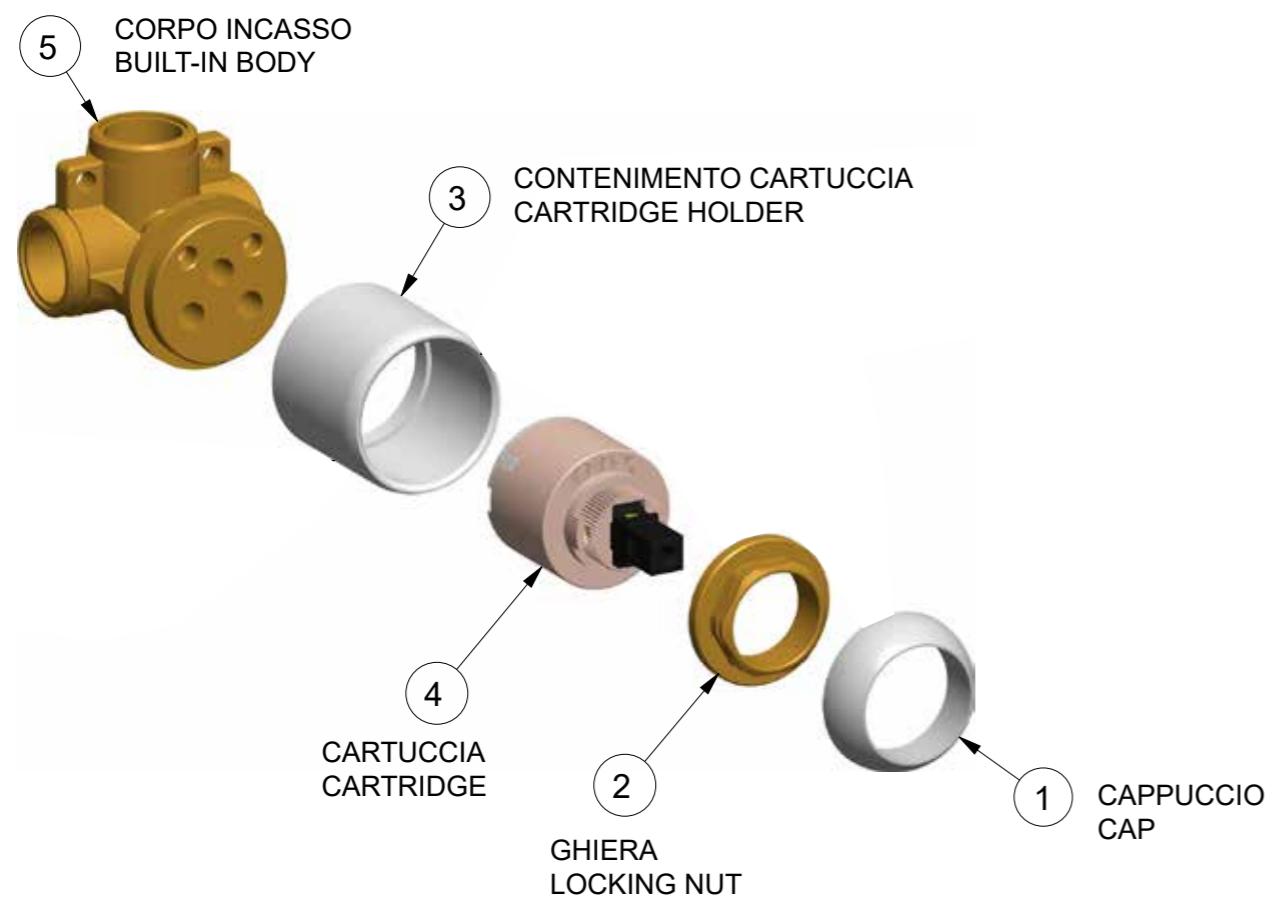

NUOVO MODELLO EASY K-BOX

NEW MODEL EASY K-BOX

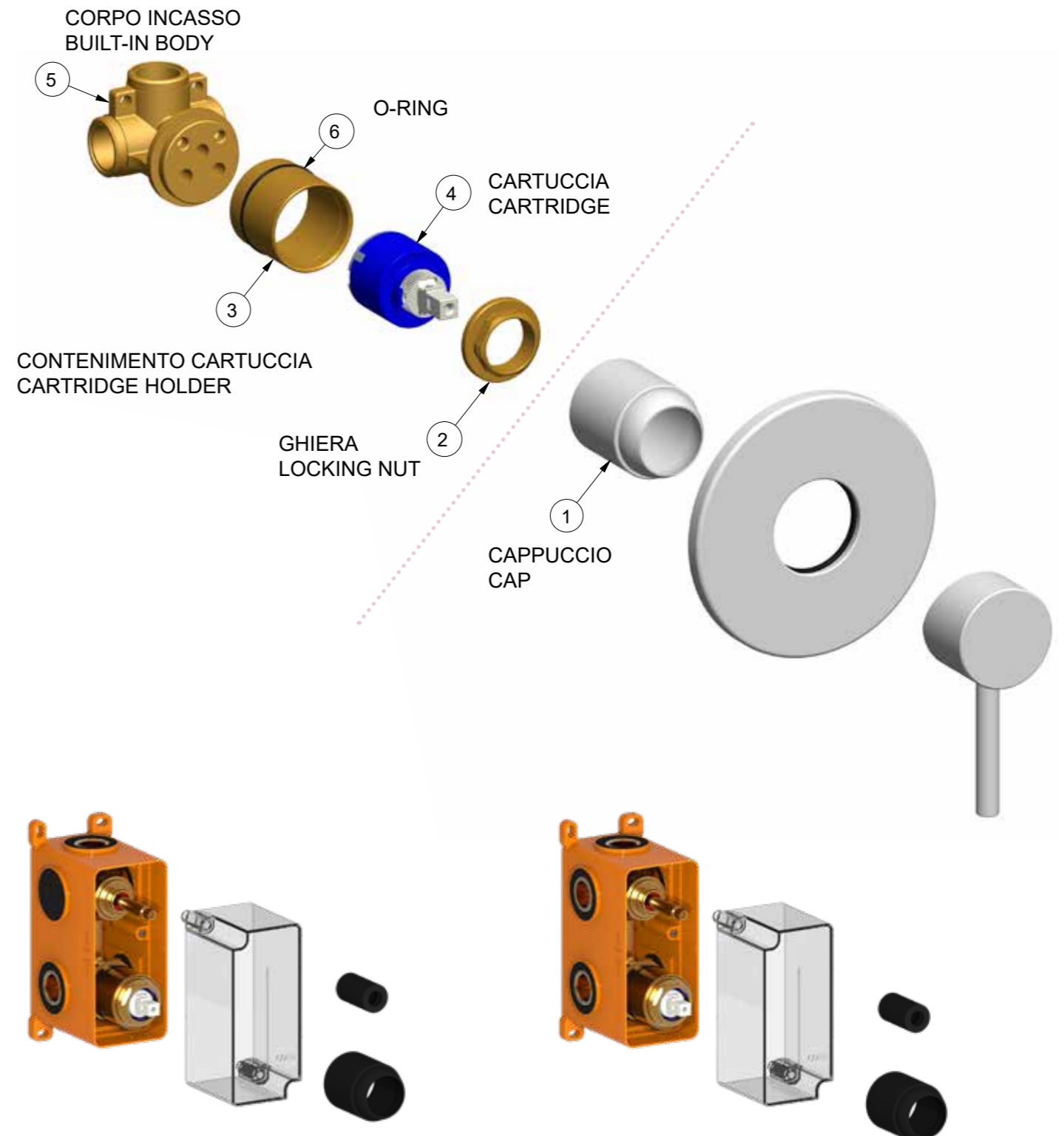

# EASY K-BOX \_ EASY COVER

CORPO INCASSO

BUILT-IN BODY

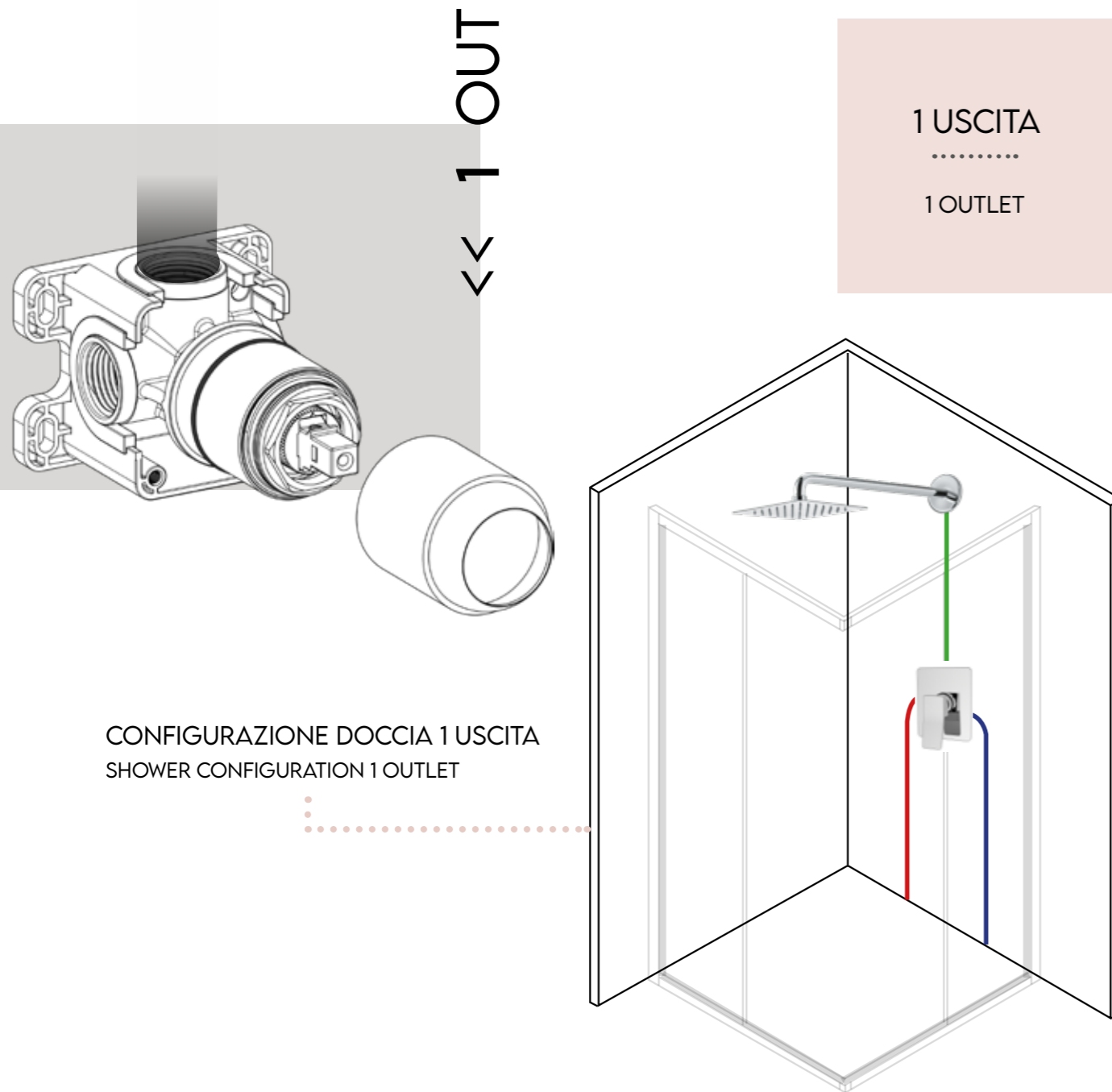

CONFIGURAZIONE DOCCIA 1 USCITA  
SHOWER CONFIGURATION 1 OUTLET

1 USCITA  
.....  
1 OUTLET

## AC5001



Corpo incasso 1 uscita EASY K-BOX.  
EASY K-BOX 1-way built-in body.  
Corps à encastrer 1 sortie EASY K-BOX.  
Unterputzkörper 1-Weg EASY K-BOX.  
Cuerpo empotrable 1 salida EASY K-BOX.

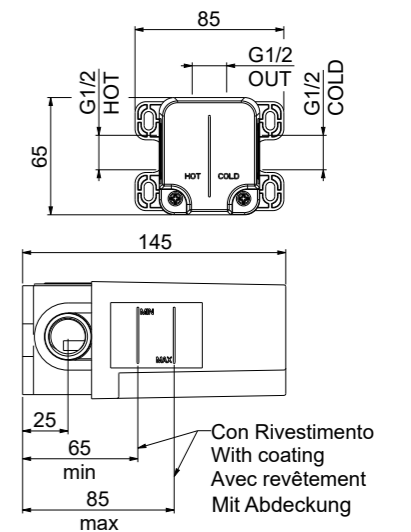

.000 Ottone / Brass / Laiton / Messing / Latón € 55,00

Questi miscelatori sono progettati per controllare il flusso e la temperatura dell'acqua per una singola uscita, che di solito è il soffione della doccia. Sono costituiti principalmente da una valvola miscelatrice interna che regola il flusso dell'acqua calda e fredda e un'impugnatura esterna per controllare la temperatura e il flusso.

These mixers are designed to control the flow and temperature of water for a single outlet, which is usually the shower head. They mainly consist of an internal mixing valve that regulates the flow of hot and cold water and an external handle to control the temperature and flow.

## AC5104

PIASTRA CON BORDO E GUARNIZIONE  
PLATE WITH RAISED EDGE AND GASKET

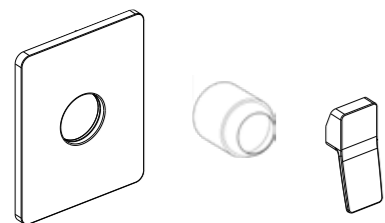

	OMBRA PLUS	OMBRA	PEGASO	ELIO / ELIO SLIM
				
	OP885104	OR885104	PE885104	EL885104
.015 Cromo / Chrome	€ 47,00	€ 47,00	€ 51,00	€ 58,00
.560 Nero opaco / Matt Black	€ 66,00	€ 66,00	€ 71,00	€ 81,00
.740 Bianco opaco / Matt white	€ 66,00	€ 66,00	€ 71,00	X
.345 Simil acciaio / Steel	X	X	X	€ 93,00
.980 Oro rosa / Rose Gold	X	X	X	X
.010 Oro / Gold	X	X	X	X
.065 Bronzo / Bronze	X	X	X	X
COLLEZIONE PRIMAVERA	€ 85,00	€ 85,00	€ 92,00	€ 104,00

PARTE ESTERNA COMPLETA DI PIASTRA,  
LEVA E CAPPUCCIO

EXTERNAL PART COMPLETE WITH PLATE,  
LEVER AND CAP

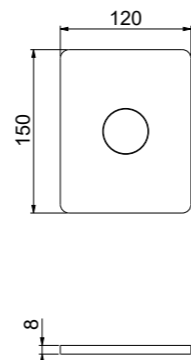

PARTE ESTERNA DA UTILIZZARE SOLO  
CON CORPO INCASSO **AC5001**  
EXTERNAL PART TO BE USED ONLY  
WITH BUILT-IN BODY **AC5001**

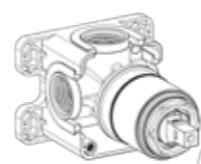

## AC5103

PIASTRA CON BORDO E GUARNIZIONE  
PLATE WITH RAISED EDGE AND GASKET



	ELIO / ELIO SLIM	DOREMI	OPERA	OPERA MODERNA	DIADEMA
					
	EL885103	DR885103	OA885103	OE885103	DD885103
.015 Cromo / Chrome	€ 60,00	€ 54,00	€ 88,00	€ 63,00	€ 60,00
.560 Nero opaco / Matt Black	€ 84,00	€ 76,00	€ 123,00	€ 88,00	€ 84,00
.740 Bianco opaco / Matt white	X	X	X	X	X
.345 Simil acciaio / Steel	€ 96,00	€ 86,00	X	X	X
.980 Oro rosa / Rose Gold	X	X	€ 185,00	X	X
.010 Oro / Gold	X	X	€ 176,00	X	X
.065 Bronzo / Bronze	X	X	€ 141,00	X	X
COLLEZIONE PRIMAVERA	€ 108,00	€ 97,00	€ 158,00	X	X

PARTE ESTERNA COMPLETA DI PIASTRA,  
LEVA E CAPPUCCIO

EXTERNAL PART COMPLETE WITH PLATE,  
LEVER AND CAP

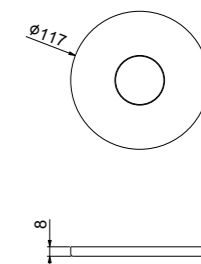



PARTE ESTERNA DA UTILIZZARE  
SOLO CON CORPO INCASSO  
**AC5001**  
EXTERNAL PART TO BE USED ONLY  
WITH BUILT-IN BODY **AC5001**

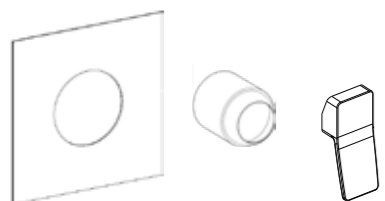

## AC5102

PIASTRA SPESSORE 1 mm  
PLATE 1 mm THICK



	OMBRA PLUS	OMBRA	PEGASO	ELIO / ELIO SLIM
				
	OP885102	OR885102	PE885102	EL885102
.015 Cromo / Chrome	€ 56,00	€ 56,00	€ 60,00	€ 67,00
.560 Nero opaco / Matt Black	€ 78,00	€ 78,00	€ 84,00	€ 94,00
.740 Bianco opaco / Matt white	€ 78,00	€ 78,00	€ 84,00	X
.345 Simil acciaio / Steel	X	X	X	€ 107,00
.980 Oro rosa / Rose Gold	X	X	X	X
.010 Oro / Gold	X	X	X	X
.065 Bronzo / Bronze	X	X	X	X
COLLEZIONE PRIMAVERA	€ 101,00	€ 101,00	€ 108,00	€ 121,00

PARTE ESTERNA COMPLETA DI PIASTRA,  
LEVA E CAPPUCCIO

EXTERNAL PART COMPLETE WITH PLATE,  
LEVER AND CAP

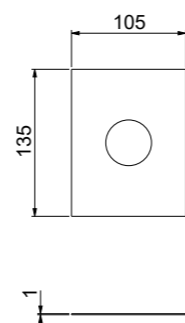

PARTE ESTERNA DA UTILIZZARE SOLO  
CON CORPO INCASSO **AC5001**  
EXTERNAL PART TO BE USED ONLY  
WITH BUILT-IN BODY **AC5001**

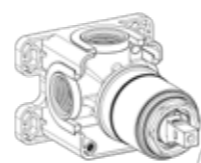

## AC5101

PIASTRA SPESSORE 1 mm  
PLATE 1 mm THICK



	ELIO / ELIO SLIM	DOREMI	OPERA	OPERA MODERNA	DIADEMA
					
	EL885101	DR885101	OA885101	OE885101	DD885101
.015 Cromo / Chrome	€ 69,00	€ 63,00	€ 97,00	€ 72,00	€ 69,00
.560 Nero opaco / Matt Black	€ 97,00	€ 88,00	€ 136,00	€ 101,00	€ 97,00
.740 Bianco opaco / Matt white	X	X	X	X	X
.345 Simil acciaio / Steel	€ 110,00	€ 101,00	X	X	X
.980 Oro rosa / Rose Gold	X	X	€ 204,00	X	X
.010 Oro / Gold	X	X	€ 194,00	X	X
.065 Bronzo / Bronze	X	X	€ 155,00	X	X
COLLEZIONE PRIMAVERA	€ 124,00	€ 113,00	€ 175,00	X	X

PARTE ESTERNA COMPLETA DI PIASTRA,  
LEVA E CAPPUCCIO

EXTERNAL PART COMPLETE WITH PLATE,  
LEVER AND CAP

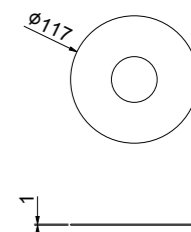

PARTE ESTERNA DA UTILIZZARE  
SOLO CON CORPO INCASSO  
**AC5001**  
EXTERNAL PART TO BE USED ONLY  
WITH BUILT-IN BODY **AC5001**



# EASY K-BOX \_ EASY COVER

## CORPO INCASSO

### BUILT-IN BODY

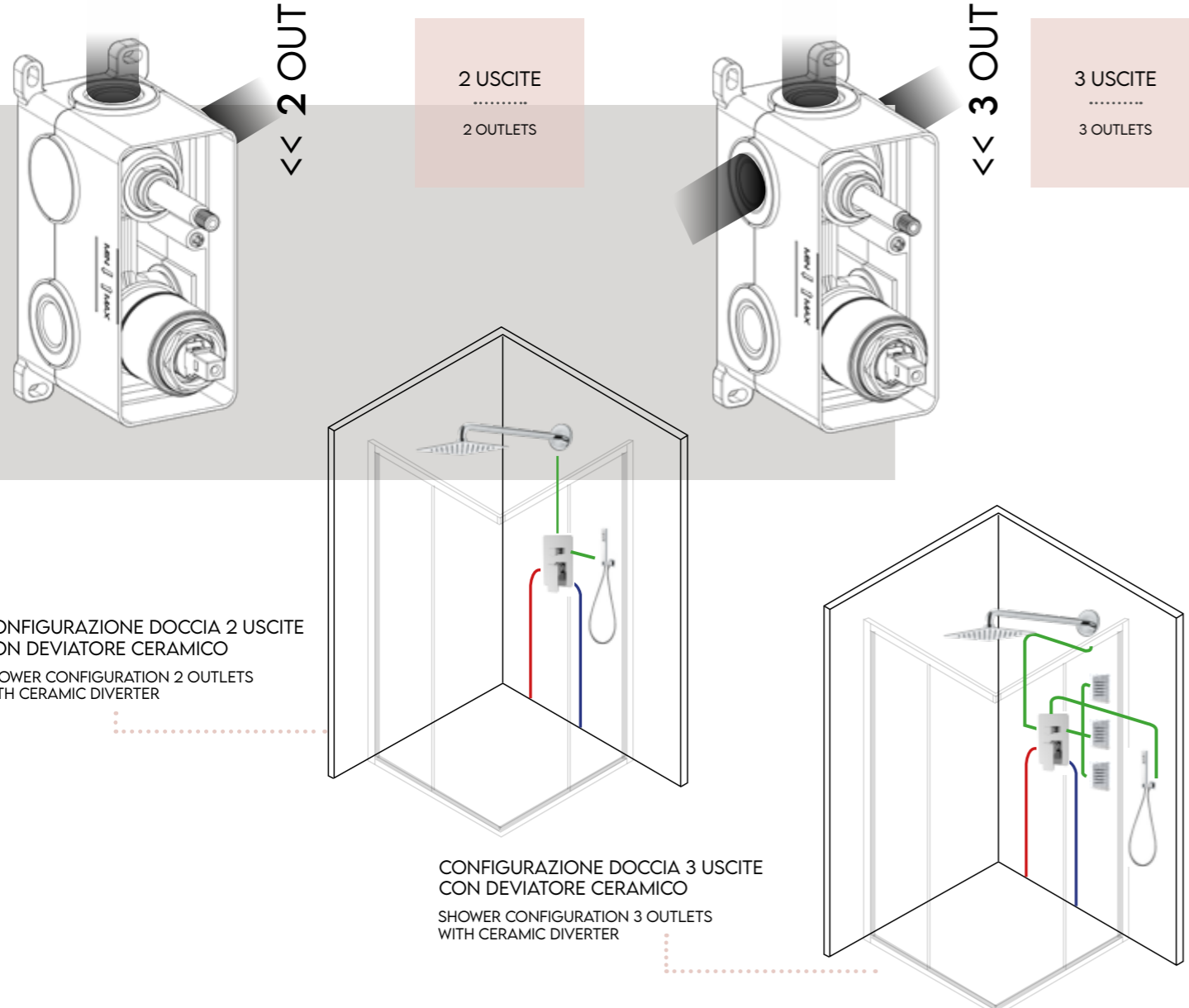

CONFIGURAZIONE DOCCIA 2 USCITE  
CON DEVIATORE CERAMICO  
SHOWER CONFIGURATION 2 OUTLETS  
WITH CERAMIC DIVERTER

CONFIGURAZIONE DOCCIA 3 USCITE  
CON DEVIATORE CERAMICO  
SHOWER CONFIGURATION 3 OUTLETS  
WITH CERAMIC DIVERTER

Questi miscelatori hanno due o tre uscite che possono essere utilizzate per controllare due flussi d'acqua separati, ad esempio un soffione a soffitto e una doccia a parete. Hanno una struttura simile ai miscelatori con una sola uscita, ma con una valvola aggiuntiva chiamata deviatore che devia il flusso fra la prima, la seconda uscita e la terza uscita, il deviatore può essere meccanico, per le due uscite quindi con pulsante da premere per deviare che torna poi alla posizione originaria, oppure con deviatore ceramico per le due uscite e le tre uscite moderno ed ergonomico. Anche in questo caso, l'utente può regolare la temperatura e il flusso dell'acqua attraverso un'unica impugnatura esterna.

These mixers have two or three outlets that can be used to control two separate water flows, for example a ceiling-mounted shower head and a wall-mounted shower. They have a similar structure to 1-outlet mixers, but with an additional valve called a diverter that diverts the flow between the first, second and third outlet. The diverter can be mechanical, for the two outlets then with a button to press to divert which then returns to the original position, or with ceramic diverter for the two outlets and the three outlets, modern and ergonomic. Also in this case, the user can adjust the temperature and water flow through a single external handle.

## AC5002



Corpo incasso 2 vie EASY K-BOX.

EASY K-BOX 2-way built-in body.

Corps a encastré 2 sorties EASY K-BOX.

Unterputzkörper 2-Wege EASY K-BOX.

Cuerpo empotrable 2 salidas EASY K-BOX.

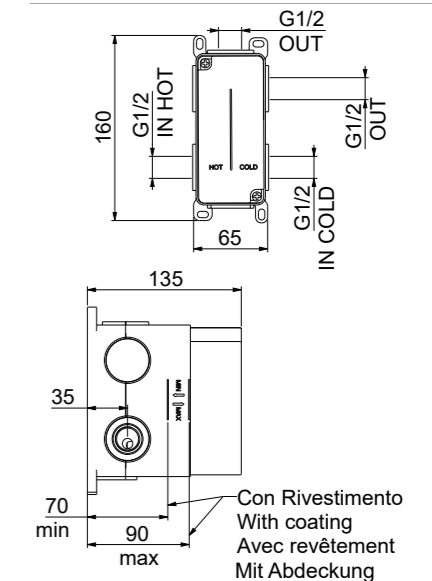

.000 Ottone / Brass / Laiton / Messing / Latón

€ 117,00

## AC5003



Corpo incasso 3 vie EASY K-BOX.

EASY K-BOX 3-way built-in body.

Corps a encastré 3 sorties EASY K-BOX.

Unterputzkörper 3-Wege EASY K-BOX.

Cuerpo empotrable 3 salidas EASY K-BOX.

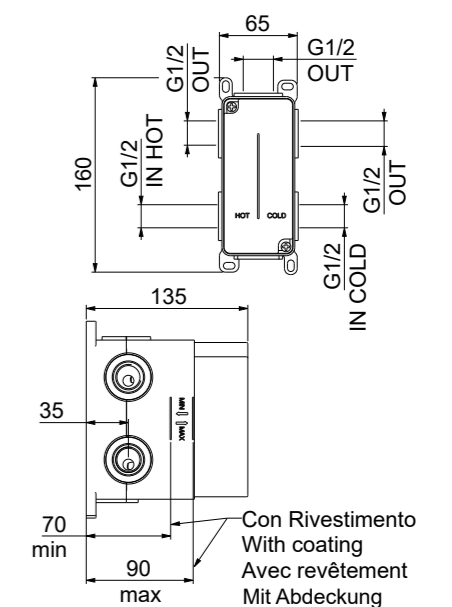

.000 Ottone / Brass / Laiton / Messing / Latón

€ 119,00

## AC5204

PIASTRA CON BORDO E GUARNIZIONE  
PLATE WITH RAISED EDGE AND GASKET

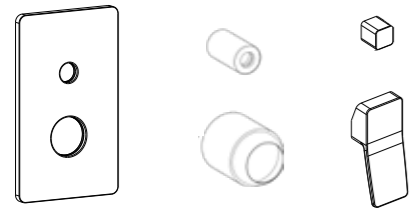

	OMBRA PLUS OP865204	OMBRA OR865204	PEGASO PE865204	ELIO / ELIO SLIM EL865204
.015 Cromo / Chrome	€ 104,00	€ 104,00	€ 108,00	€ 113,00
.560 Nero opaco / Matt Black	€ 146,00	€ 146,00	€ 151,00	€ 158,00
.740 Bianco opaco / Matt white	€ 146,00	€ 146,00	€ 151,00	X
.345 Simil acciaio / Steel	X	X	X	€ 181,00
.980 Oro rosa / Rose Gold	X	X	X	X
.010 Oro / Gold	X	X	X	X
.065 Bronzo / Bronze	X	X	X	X
COLLEZIONE PRIMAVERA	€ 187,00	€ 187,00	€ 194,00	€ 203,00

PARTE ESTERNA COMPLETA DI PIASTRA, LEVA,  
CAPPuccio, COPRIDEVIATORE E POMOLO

EXTERNAL PART COMPLETE WITH PLATE,  
LEVER, CAP, DIVERTER COVER AND KNOB

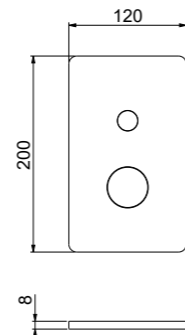

PARTE ESTERNA DA UTILIZZARE SOLO  
CON CORPO INCASSO AC5002 O AC5003  
EXTERNAL PART TO BE USED ONLY  
WITH BUILT-IN BODY AC5002 O AC5003

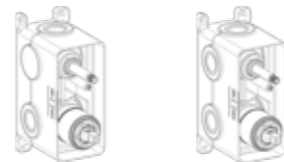

## AC5203

PIASTRA CON BORDO E GUARNIZIONE  
PLATE WITH RAISED EDGE AND GASKET

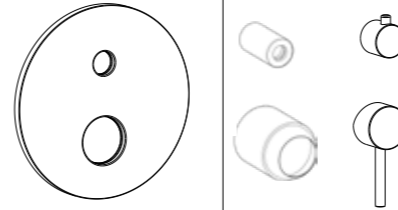

	ELIO / ELIO SLIM EL865203	DOREMI DR865203	OPERA OA865203	OPERA MODERNA OE865203	DIADEMA DD865203
.015 Cromo / Chrome	€ 109,00	€ 103,00	€ 137,00	€ 112,00	€ 109,00
.560 Nero opaco / Matt Black	€ 153,00	€ 144,00	€ 192,00	€ 157,00	€ 153,00
.740 Bianco opaco / Matt white	X	X	X	X	X
.345 Simil acciaio / Steel	€ 174,00	€ 165,00	X	X	X
.980 Oro rosa / Rose Gold	X	X	€ 288,00	X	X
.010 Oro / Gold	X	X	€ 274,00	X	X
.065 Bronzo / Bronze	X	X	€ 219,00	X	X
COLLEZIONE PRIMAVERA	€ 196,00	€ 185,00	€ 247,00	X	X

PARTE ESTERNA COMPLETA DI PIASTRA, LEVA,  
CAPPuccio, COPRIDEVIATORE E POMOLO

EXTERNAL PART COMPLETE WITH PLATE,  
LEVER, CAP, DIVERTER COVER AND KNOB

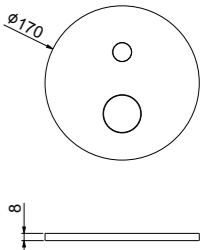

PARTE ESTERNA DA UTILIZZARE  
SOLO CON CORPO INCASSO  
AC5002 O AC5003

EXTERNAL PART TO BE USED  
ONLY WITH BUILT-IN BODY  
AC5002 O AC5003

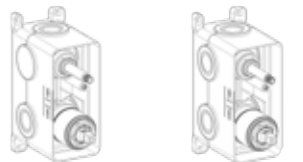

## AC5202

PIASTRA SPESSORE 1 mm  
PLATE 1 mm THICK

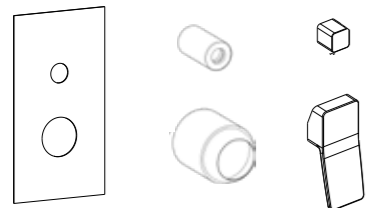

	OMBRA PLUS OP865202	OMBRA OR865202	PEGASO PE865202	ELIO / ELIO SLIM EL865202
.015 Cromo / Chrome	€ 106,00	€ 106,00	€ 110,00	€ 115,00
.560 Nero opaco / Matt Black	€ 148,00	€ 148,00	€ 154,00	€ 161,00
.740 Bianco opaco / Matt white	€ 148,00	€ 148,00	€ 154,00	X
.345 Simil acciaio / Steel	X	X	X	€ 184,00
.980 Oro rosa / Rose Gold	X	X	X	X
.010 Oro / Gold	X	X	X	X
.065 Bronzo / Bronze	X	X	X	X
COLLEZIONE PRIMAVERA	€ 191,00	€ 191,00	€ 198,00	€ 207,00

PARTE ESTERNA COMPLETA DI PIASTRA, LEVA,  
CAPPuccio, COPRIDEVIATORE E POMOLO

EXTERNAL PART COMPLETE WITH PLATE,  
LEVER, CAP, DIVERTER COVER AND KNOB

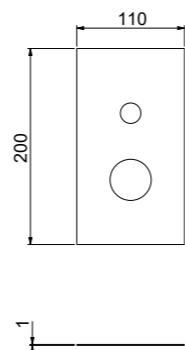

PARTE ESTERNA DA UTILIZZARE SOLO  
CON CORPO INCASSO AC5002 O AC5003  
EXTERNAL PART TO BE USED ONLY  
WITH BUILT-IN BODY AC5002 O AC5003

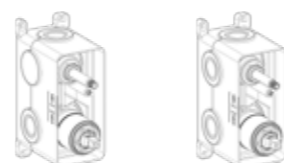

## AC5201

PIASTRA SPESSORE 1 mm  
PLATE 1 mm THICK

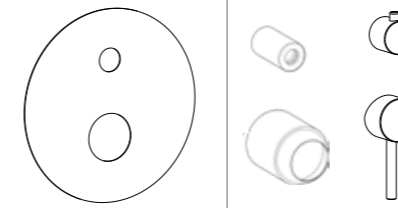

	ELIO / ELIO SLIM EL865201	DOREMI DR865201	OPERA OA865201	OPERA MODERNA OE865201	DIADEMA DD865201
.015 Cromo / Chrome	€ 117,00	€ 111,00	€ 145,00	€ 120,00	€ 117,00
.560 Nero opaco / Matt Black	€ 164,00	€ 155,00	€ 203,00	€ 168,00	€ 164,00
.740 Bianco opaco / Matt white	X	X	X	X	X
.345 Simil acciaio / Steel	€ 187,00	€ 178,00	X	X	X
.980 Oro rosa / Rose Gold	X	X	€ 305,00	X	X
.010 Oro / Gold	X	X	€ 290,00	X	X
.065 Bronzo / Bronze	X	X	€ 232,00	X	X
COLLEZIONE PRIMAVERA	€ 211,00	€ 200,00	€ 261,00	X	X

PARTE ESTERNA COMPLETA DI PIASTRA, LEVA,  
CAPPuccio, COPRIDEVIATORE E POMOLO

EXTERNAL PART COMPLETE WITH PLATE,  
LEVER, CAP, DIVERTER COVER AND KNOB

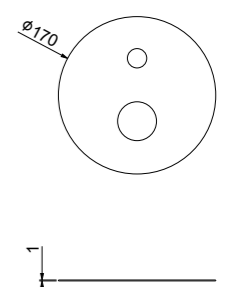

PARTE ESTERNA DA UTILIZZARE  
SOLO CON CORPO INCASSO  
AC5002 O AC5003

EXTERNAL PART TO BE USED  
ONLY WITH BUILT-IN BODY  
AC5002 O AC5003

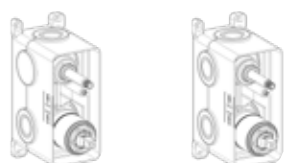

## EASY K-BOX \_ EASY COVER

### CORPO INCASSO PER LAVABO A MURO CON PIASTRA INTEGRALE UNICA

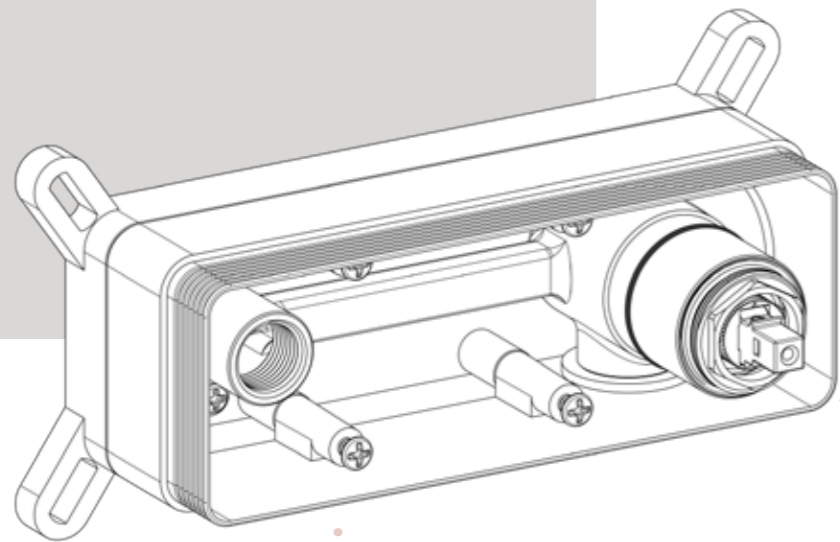

LAVABO A MURO

\*\*\*\*\*  
WALL BASIN MIXER

CORPO INCASSO PER LAVABO A MURO  
CON PIASTRA INTEGRALE UNICA

BUILT-IN BODY FOR WALL BASIN MIXER WITH  
SINGLE HORIZONTAL PLATE

Il nostro nuovo progetto sui corpi incasso è un'ottima soluzione per chi desidera combinare funzionalità, estetica e flessibilità. Un nuovo modo di vedere e di vivere la progettazione dell'ambiente bagno per quanto riguarda miscelatori da incasso lavabo e doccia, che offre la libertà di decidere senza limiti.

La possibilità di installazione solo del corpo incasso facilita sia il lavoro dell'idraulico, il quale può procedere senza le parti esterne, sia il cliente che ha tutto il tempo di decidere comodamente design e finitura per rispettare lo stile del bagno.

Our new design on concealed bodies is an excellent solution for those who wish to combine functionality, aesthetics and flexibility. A new way of looking at and experiencing bathroom design with regard to concealed basin and shower mixers, which offers the freedom to decide without limits.

The possibility of installing only the built-in body facilitates both the work of the plumber, who can proceed without the external parts, as well as the customer who has plenty of time to comfortably decide on the design and finish to match the style of the bathroom.

## CORPO INCASSO LAVABO A MURO

### WALL BASIN MIXER BUILT-IN BODY

**AC5004**

Corpo incasso EASY K-BOX per lavabo a muro con piastra integrale unica.

EASY K-BOX built-in body for wall basin mixer with single plate.

Corps à encastrer EASY K-BOX pour mitigeur lavabo mural avec plaque unique.

Unterputzkörper EASY K-BOX für Wand-Waschtischmischer mit Einzelplatte.

Cuerpo empotrable EASY K-BOX para mezclador de lavabo de pared con placa horizontal.

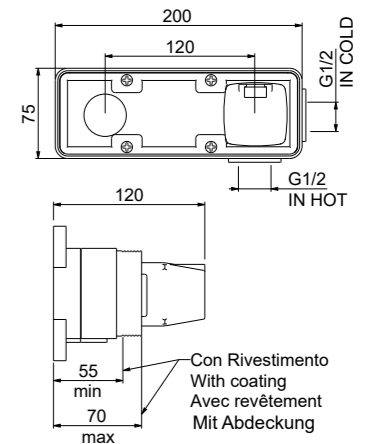

.000 Ottone / Brass / Laiton / Messing / Latón € 89,00

PIASTRA CON BORDO E GUARNIZIONE  
PLATE WITH RAISED EDGE AND GASKET

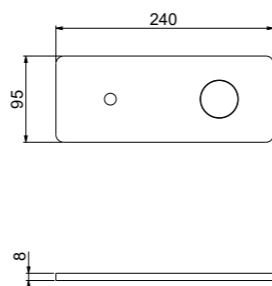
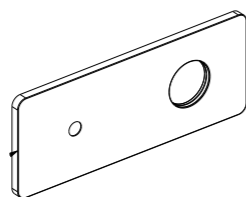

PARTI ESTERNE COMPLETE DI PIASTRA, LEVA,  
CAPPuccio, BOCCA E RACCORDO

EXTERNAL PARTS COMPLETE WITH PLATE,  
LEVER, CAP, SPOUT AND CONNECTION

### OP835414 \_ OMBRA PLUS

PIASTRA CON BORDO E GUARNIZIONE  
PLATE WITH RAISED EDGE AND GASKET



Parte esterna per lavabo a muro con piastra integrale unica.  
External part for wall basin mixer with single plate.  
Partie extérieure pour lavabo mural avec plaque unique.  
Außenteil für Wand-Waschtischmischer mit Einzelplatte.  
Parte exterior para lavabo de pared con placa horizontal.

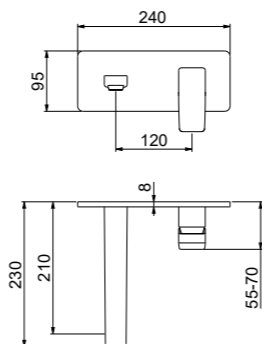

- .015 Cromo / Chrome / Chromée / Verchromt / Cromado € 137,00
- .560 Nero opaco / Matt black / Noir mat / Matt Schwarz / Negro mate € 192,00
- Collezione Primavera € 247,00

PARTE ESTERNA DA UTILIZZARE  
SOLO CON CORPO INCASSO  
**AC5004**

EXTERNAL PART TO BE USED  
ONLY WITH BUILT-IN BODY  
**AC5004**



### OR835414 \_ OMBRA

PIASTRA CON BORDO E GUARNIZIONE  
PLATE WITH RAISED EDGE AND GASKET

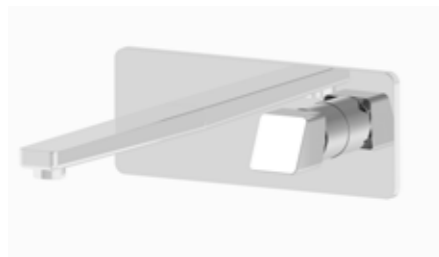

Parte esterna per lavabo a muro con piastra integrale unica.  
External part for wall basin mixer with single plate.  
Partie extérieure pour lavabo mural avec plaque unique.  
Außenteil für Wand-Waschtischmischer mit Einzelplatte.  
Parte exterior para lavabo de pared con placa horizontal.

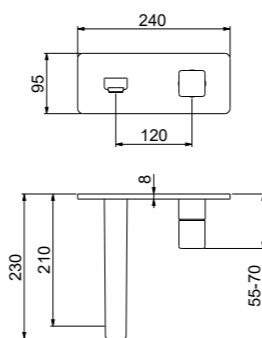

- .015 Cromo / Chrome / Chromée / Verchromt / Cromado € 137,00
- .560 Nero opaco / Matt black / Noir mat / Matt Schwarz / Negro mate € 192,00
- Collezione Primavera € 247,00

PARTE ESTERNA DA UTILIZZARE  
SOLO CON CORPO INCASSO  
**AC5004**

EXTERNAL PART TO BE USED  
ONLY WITH BUILT-IN BODY  
**AC5004**



PIASTRA CON BORDO E GUARNIZIONE  
PLATE WITH RAISED EDGE AND GASKET

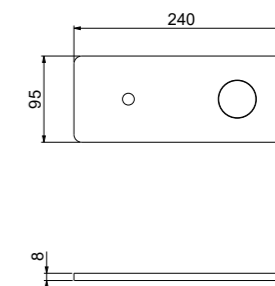
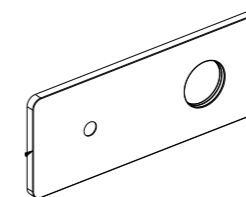

PARTI ESTERNE COMPLETE DI PIASTRA, LEVA,  
CAPPuccio, BOCCA E RACCORDO

EXTERNAL PARTS COMPLETE WITH PLATE,  
LEVER, CAP, SPOUT AND CONNECTION

### PE835424 \_ PEGASO

PIASTRA CON BORDO E GUARNIZIONE  
PLATE WITH RAISED EDGE AND GASKET

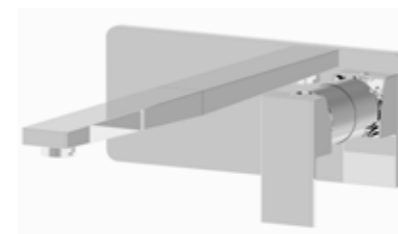

Parte esterna per lavabo a muro con piastra integrale unica.  
External part for wall basin mixer with single plate.  
Partie extérieure pour lavabo mural avec plaque unique.  
Außenteil für Wand-Waschtischmischer mit Einzelplatte.  
Parte exterior para lavabo de pared con placa horizontal.

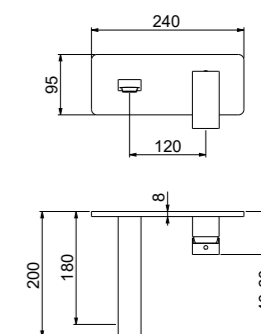

- .015 Cromo / Chrome / Chromée / Verchromt / Cromado € 141,00
- .560 Nero opaco / Matt black / Noir mat / Matt Schwarz / Negro mate € 197,00
- .740 Bianco opaco / Matt white / Blanc mat / Matt Weiss / Blanco mate € 197,00
- Collezione Primavera € 254,00

PARTE ESTERNA DA UTILIZZARE  
SOLO CON CORPO INCASSO  
**AC5004**

EXTERNAL PART TO BE USED  
ONLY WITH BUILT-IN BODY  
**AC5004**



### EL835404 \_ ELIO / ELIO SLIM

PIASTRA CON BORDO E GUARNIZIONE  
PLATE WITH RAISED EDGE AND GASKET

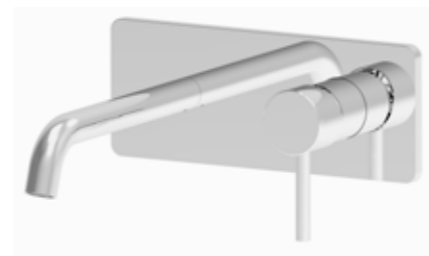

Parte esterna per lavabo a muro con piastra integrale unica.  
External part for wall basin mixer with single plate.  
Partie extérieure pour lavabo mural avec plaque unique.  
Außenteil für Wand-Waschtischmischer mit Einzelplatte.  
Parte exterior para lavabo de pared con placa horizontal.

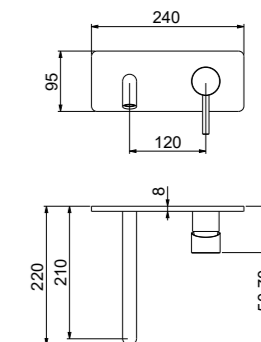

- .015 Cromo / Chrome / Chromée / Verchromt / Cromado € 132,00
- .560 Nero opaco / Matt black / Noir mat / Matt Schwarz / Negro mate € 185,00
- .345 Acciaio spazzolato / Brushed nickel / Acier brossé / Edelstahl Optik / Acero cepillado € 211,00
- Collezione Primavera € 238,00

PARTE ESTERNA DA UTILIZZARE  
SOLO CON CORPO INCASSO  
**AC5004**

EXTERNAL PART TO BE USED  
ONLY WITH BUILT-IN BODY  
**AC5004**



PARTI ESTERNE COMPLETE DI PIASTRA, LEVA,  
CAPPuccio, BOCCA E RACCORDO

EXTERNAL PARTS COMPLETE WITH PLATE,  
LEVER, CAP, SPOUT AND CONNECTION

PIASTRA SPESSORE 1 mm  
PLATE 1 mm THICK

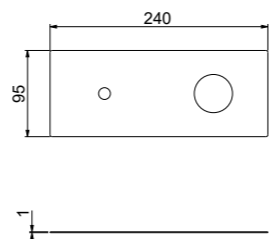
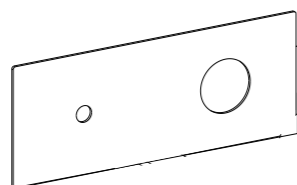

PIASTRA SPESSORE 1 mm  
PLATE 1 mm THICK

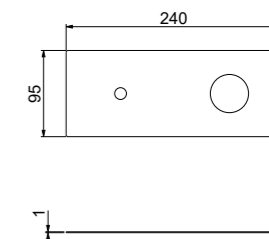
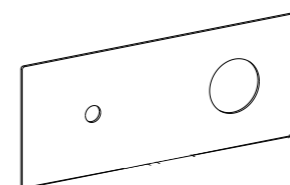

PARTI ESTERNE COMPLETE DI PIASTRA, LEVA,  
CAPPuccio, BOCCA E RACCORDO

EXTERNAL PARTS COMPLETE WITH PLATE,  
LEVER, CAP, SPOUT AND CONNECTION

### OP835412 \_ OMBRA PLUS

PIASTRA SPESSORE 1 mm  
PLATE 1 mm THICK

Parte esterna per lavabo a muro con piastra integrale unica.

External part for wall basin mixer with single plate.

Partie extérieure pour lavabo mural avec plaque unique.

Außenteil für Wand-Waschtischmischer mit Einzelplatte.

Parte exterior para lavabo de pared con placa horizontal.

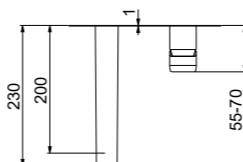
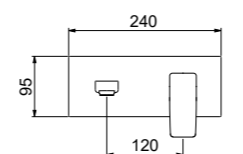

PARTE ESTERNA DA UTILIZZARE  
SOLO CON CORPO INCASSO  
**AC5004**

EXTERNAL PART TO BE USED  
ONLY WITH BUILT-IN BODY  
**AC5004**



.015 Cromo / Chrome / Chromée / Verchromt / Cromado € 140,00

.560 Nero opaco / Matt black / Noir mat / Matt Schwarz / Negro mate € 196,00

Collezione Primavera € 252,00

### PE835422 \_ PEGASO

PIASTRA SPESSORE 1 mm  
PLATE 1 mm THICK

Parte esterna per lavabo a muro con piastra integrale unica.

External part for wall basin mixer with single plate.

Partie extérieure pour lavabo mural avec plaque unique.

Außenteil für Wand-Waschtischmischer mit Einzelplatte.

Parte exterior para lavabo de pared con placa horizontal.

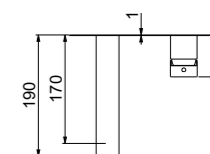
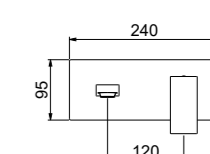
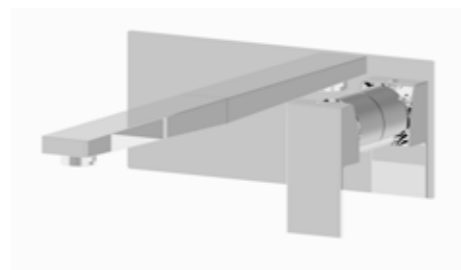

PARTE ESTERNA DA UTILIZZARE  
SOLO CON CORPO INCASSO  
**AC5004**

EXTERNAL PART TO BE USED  
ONLY WITH BUILT-IN BODY  
**AC5004**



.015 Cromo / Chrome / Chromée / Verchromt / Cromado € 144,00

.560 Nero opaco / Matt black / Noir mat / Matt Schwarz / Negro mate € 202,00

.740 Bianco opaco / Matt white / Blanc mat / Matt Weiss / Blanco mate € 202,00

Collezione Primavera € 259,00

### OR835412 \_ OMBRA

PIASTRA SPESSORE 1 mm  
PLATE 1 mm THICK

Parte esterna per lavabo a muro con piastra integrale unica.

External part for wall basin mixer with single plate.

Partie extérieure pour lavabo mural avec plaque unique.

Außenteil für Wand-Waschtischmischer mit Einzelplatte.

Parte exterior para lavabo de pared con placa horizontal.

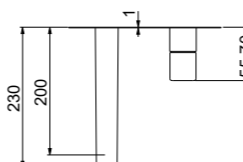
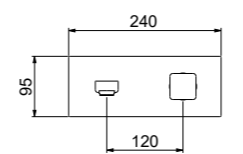

PARTE ESTERNA DA UTILIZZARE  
SOLO CON CORPO INCASSO  
**AC5004**

EXTERNAL PART TO BE USED  
ONLY WITH BUILT-IN BODY  
**AC5004**



.015 Cromo / Chrome / Chromée / Verchromt / Cromado € 140,00

.560 Nero opaco / Matt black / Noir mat / Matt Schwarz / Negro mate € 196,00

Collezione Primavera € 252,00

### EL835402\_ ELIO / ELIO SLIM

PIASTRA SPESSORE 1 mm  
PLATE 1 mm THICK

Parte esterna per lavabo a muro con piastra integrale unica.

External part for wall basin mixer with single plate.

Partie extérieure pour lavabo mural avec plaque unique.

Außenteil für Wand-Waschtischmischer mit Einzelplatte.

Parte exterior para lavabo de pared con placa horizontal.

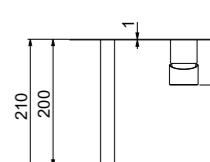
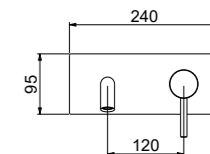
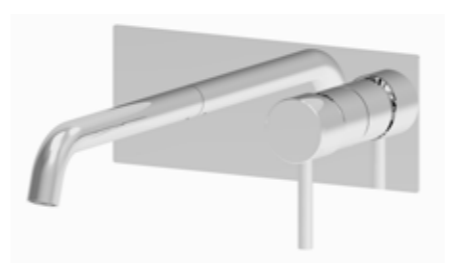

PARTE ESTERNA DA UTILIZZARE  
SOLO CON CORPO INCASSO  
**AC5004**

EXTERNAL PART TO BE USED  
ONLY WITH BUILT-IN BODY  
**AC5004**



.015 Cromo / Chrome / Chromée / Verchromt / Cromado € 135,00

.560 Nero opaco / Matt black / Noir mat / Matt Schwarz / Negro mate € 189,00

.345 Acciaio spazzolato / Brushed nickel / Acier brossé / Edelstahl Optik / Acero cepillado € 216,00

Collezione Primavera € 243,00

PIASTRA SPESSORE 1 mm  
PLATE 1 mm THICK

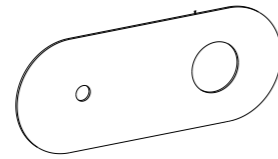

PARTI ESTERNE COMPLETE DI PIASTRA, LEVA,  
CAPPUCCIO, BOCCA E RACCORDO

EXTERNAL PARTS COMPLETE WITH PLATE,  
LEVER, CAP, SPOUT AND CONNECTION

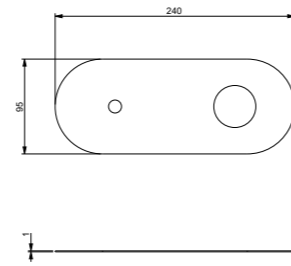

## DR835405 \_ DOREMI

PIASTRA SPESSORE 1 mm  
PLATE 1 mm THICK

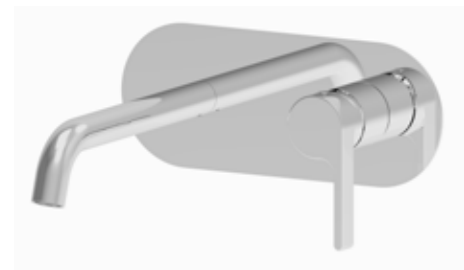

Parte esterna per lavabo a muro con piastra integrale unica.

External part for wall basin mixer with single plate.

Partie extérieure pour lavabo mural avec plaque unique.

Außenteil für Wand-Waschtischmischer mit Einzelplatte.

Parte exterior para lavabo de pared con placa horizontal.

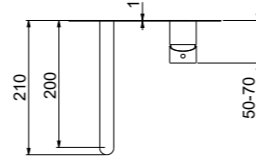
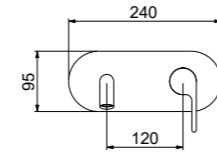

.015 Cromo / Chrome / Chromée / Verchromt / Cromado € 132,00

.560 Nero opaco / Matt black / Noir mat / Matt Schwarz / Negro mate € 184,00

.345 Acciaio spazzolato / Brushed nickel / Acier brossé / Edelstahl Optik / Acero cepillado € 211,00

Collezione Primavera € 238,00

PARTE ESTERNA DA UTILIZZARE  
SOLO CON CORPO INCASSO  
AC5004

EXTERNAL PART TO BE USED  
ONLY WITH BUILT-IN BODY  
AC5004



## EL835405 \_ ELIO / ELIO SLIM

PIASTRA SPESSORE 1 mm  
PLATE 1 mm THICK

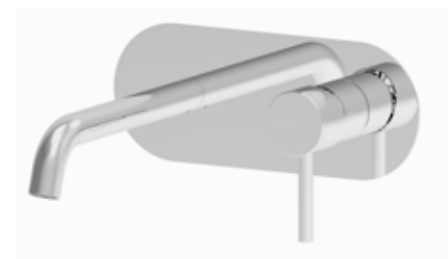

Parte esterna per lavabo a muro con piastra integrale unica.

External part for wall basin mixer with single plate.

Partie extérieure pour lavabo mural avec plaque unique.

Außenteil für Wand-Waschtischmischer mit Einzelplatte.

Parte exterior para lavabo de pared con placa horizontal.

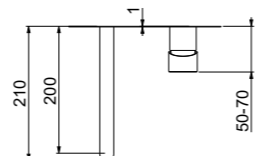
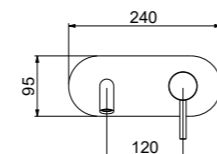

.015 Cromo / Chrome / Chromée / Verchromt / Cromado € 138,00

.560 Nero opaco / Matt black / Noir mat / Matt Schwarz / Negro mate € 193,00

.345 Acciaio spazzolato / Brushed nickel / Acier brossé / Edelstahl Optik / Acero cepillado € 221,00

Collezione Primavera € 248,00

PARTE ESTERNA DA UTILIZZARE  
SOLO CON CORPO INCASSO  
AC5004

EXTERNAL PART TO BE USED  
ONLY WITH BUILT-IN BODY  
AC5004



## OE835491 \_ OPERA MODERNA

PIASTRA SPESSORE 1 mm  
PLATE 1 mm THICK

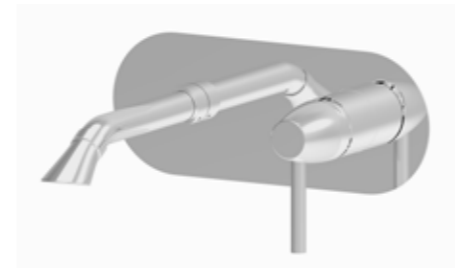

Parte esterna per lavabo a muro con piastra integrale unica.

External part for wall basin mixer with single plate.

Partie extérieure pour lavabo mural avec plaque unique.

Außenteil für Wand-Waschtischmischer mit Einzelplatte.

Parte exterior para lavabo de pared con placa horizontal.

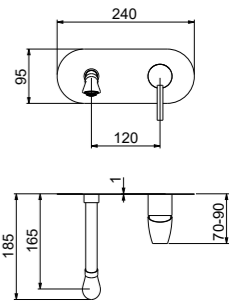

PARTE ESTERNA DA UTILIZZARE  
SOLO CON CORPO INCASSO  
AC5004

EXTERNAL PART TO BE USED  
ONLY WITH BUILT-IN BODY  
AC5004

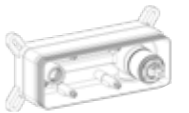

.015 Cromo / Chrome / Chromée / Verchromt / Cromado € 177,00

.560 Nero opaco / Matt black / Noir mat / Matt Schwarz / Negro mate € 248,00

## OA835491 \_ OPERA

PIASTRA SPESSORE 1 mm  
PLATE 1 mm THICK

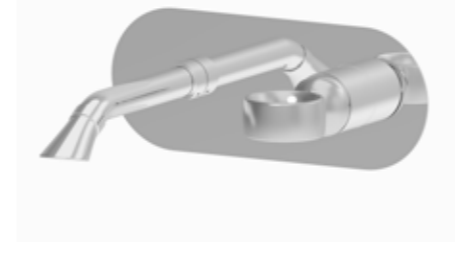

Parte esterna per lavabo a muro con piastra integrale unica.

External part for wall basin mixer with single plate.

Partie extérieure pour lavabo mural avec plaque unique.

Außenteil für Wand-Waschtischmischer mit Einzelplatte.

Parte exterior para lavabo de pared con placa horizontal.

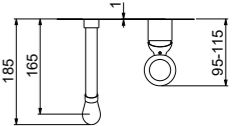
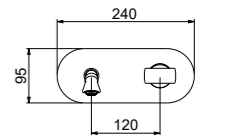

PARTE ESTERNA DA UTILIZZARE  
SOLO CON CORPO INCASSO  
AC5004

EXTERNAL PART TO BE USED  
ONLY WITH BUILT-IN BODY  
AC5004



.015 Cromo / Chrome / Chromée / Verchromt / Cromado € 202,00

.560 Nero opaco / Matt black / Noir mat / Matt Schwarz / Negro mate € 283,00

.065 Bronzo / Bronze / Bronze / Bronze / Bronze € 323,00

.010 Oro / Gold / Doré / Gold / Oro € 404,00

.980 Oro rosa / Rose gold / Or rose / Rose gold / Oro rosa € 424,00

Collezione Primavera € 364,00

## DD835405 \_ DIADEMA

PIASTRA SPESSORE 1 mm  
PLATE 1 mm THICK



Parte esterna per lavabo a muro con piastra integrale unica.

External part for wall basin mixer with single plate.

Partie extérieure pour lavabo mural avec plaque unique.

Außenteil für Wand-Waschtischmischer mit Einzelplatte.

Parte exterior para lavabo de pared con placa horizontal.

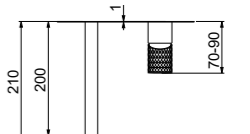
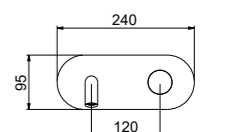

PARTE ESTERNA DA UTILIZZARE  
SOLO CON CORPO INCASSO  
AC5004

EXTERNAL PART TO BE USED  
ONLY WITH BUILT-IN BODY  
AC5004

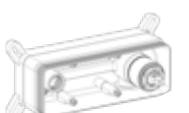

Corpo cromo / Chrome body	.015 Leva cromo / Chrome lever	€ 138,00
	.587 Leva Nero opaco / Matt black lever	€ 138,00
	.588 Leva Simil acciaio / Steel lever	€ 138,00
	.589 Leva Cromo nero / Black chrome lever	€ 138,00
	.590 Leva Grafite / Graphite lever	€ 138,00

Corpo Nero opaco / Matt black body	.591 Leva cromo / Chrome lever	€ 193,00
	.560 Leva Nero opaco / Matt black lever	€ 193,00
	.592 Leva Simil acciaio / Steel lever	€ 193,00
	.593 Leva Cromo nero / Black chrome lever	€ 193,00
	.594 Leva Grafite / Graphite lever	€ 193,00

# EASY K-BOX \_ EASY COVER

## CORPO INCASSO PER LAVABO A MURO CON PIASTRE SEPARATE

LAVABO A MURO  
.....  
WALL BASIN MIXER

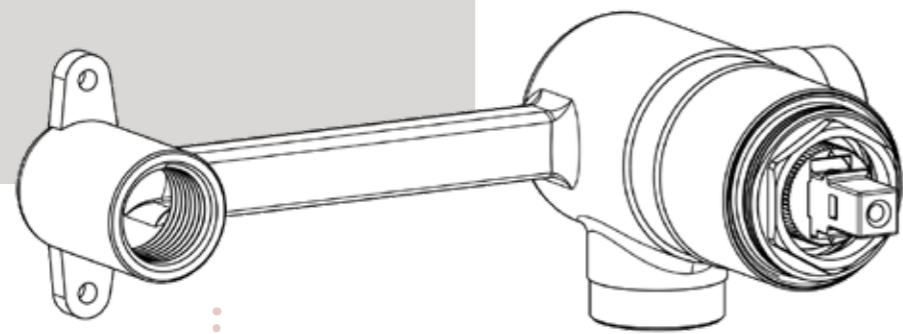

CORPO INCASSO PER LAVABO A MURO  
CON PIASTRE SEPARATE  
BUILT-IN BODY FOR WALL BASIN MIXER WITH  
SEPARATE PLATES

Il nostro nuovo progetto sui corpi incasso è un'ottima soluzione per chi desidera combinare funzionalità, estetica e flessibilità. Un nuovo modo di vedere e di vivere la progettazione dell'ambiente bagno per quanto riguarda miscelatori da incasso lavabo e doccia, che offre la libertà di decidere senza limiti. La possibilità di installazione solo del corpo incasso facilita sia il lavoro dell'idraulico, il quale può procedere senza le parti esterne, sia il cliente che ha tutto il tempo di decidere comodamente design e finitura per rispettare lo stile del bagno.

Our new design on concealed bodies is an excellent solution for those who wish to combine functionality, aesthetics and flexibility. A new way of looking at and experiencing bathroom design with regard to concealed basin and shower mixers, which offers the freedom to decide without limits. The possibility of installing only the built-in body facilitates both the work of the plumber, who can proceed without the external parts, as well as the customer who has plenty of time to comfortably decide on the design and finish to match the style of the bathroom.

## CORPO INCASSO LAVABO A MURO

## WALL BASIN MIXER BUILT-IN BODY

**AC5005**



Corpo incasso EASY K-BOX per lavabo a muro con piastre separate.

EASY K-BOX built-in body for wall basin mixer with separate plates.

Corps à encastrer EASY K-BOX pour mitigeur lavabo mural avec plaques séparées.

Unterputzkörper EASY K-BOX für Wand-Waschtischmischer mit getrennten Platten.

Cuerpo empotrable EASY K-BOX para lavabo de pared con placas separadas.

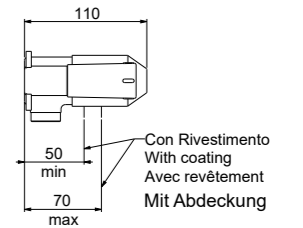
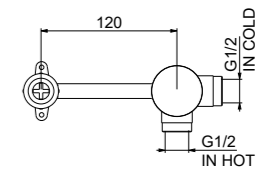

.000 Ottone / Brass / Laiton / Messing / Latón € 80,00

PIASTRA CON BORDO E GUARNIZIONE  
PLATE WITH RAISED EDGE AND GASKET

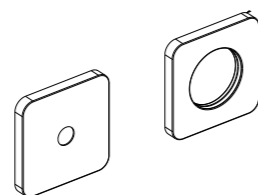

PARTI ESTERNE COMPLETE DI PIASTRE, LEVA,  
CAPPUCCIO, BOCCA E RACCORDO

EXTERNAL PARTS COMPLETE WITH PLATES, LEVER,  
CAP, SPOUT AND CONNECTION

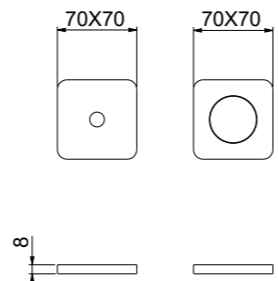

PIASTRA CON BORDO E GUARNIZIONE  
PLATE WITH RAISED EDGE AND GASKET

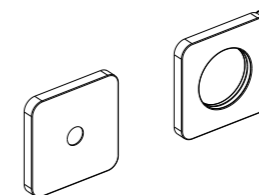

PARTI ESTERNE COMPLETE DI PIASTRE, LEVA,  
CAPPUCCIO, BOCCA E RACCORDO

EXTERNAL PARTS COMPLETE WITH PLATES, LEVER,  
CAP, SPOUT AND CONNECTION

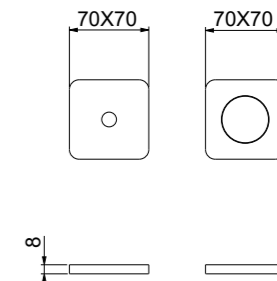

### OP835514 \_ OMBRA PLUS

PIASTRA CON BORDO E GUARNIZIONE  
PLATE WITH RAISED EDGE AND GASKET

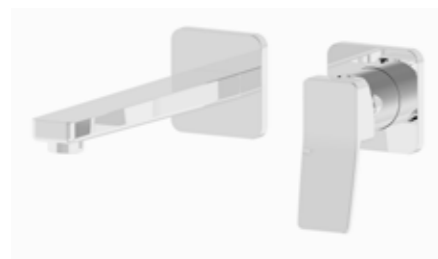

Parte esterna per lavabo a muro con piastre separate.

External part for wall basin mixer with separate plates.

Partie extérieure pour lavabo mural avec plaque séparées.

Außenteil für Wand-Waschtischmischer mit getrennten Platten.

Parte exterior para lavabo de pared con placas separadas.

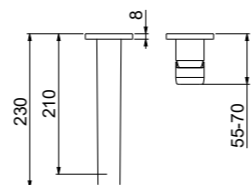
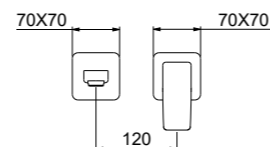

PARTE ESTERNA DA UTILIZZARE  
SOLO CON CORPO INCASSO  
**AC5005**

EXTERNAL PART TO BE USED  
ONLY WITH BUILT-IN BODY  
**AC5005**

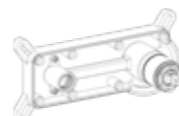

.015 Cromo / Chrome / Chromée / Verchromt / Cromado € 139,00

.560 Nero opaco / Matt black / Noir mat / Matt Schwarz / Negro mate € 195,00

Collezione Primavera € 250,00

### PE835524 \_ PEGASO

PIASTRA CON BORDO E GUARNIZIONE  
PLATE WITH RAISED EDGE AND GASKET

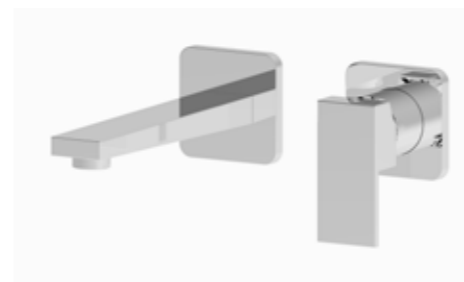

Parte esterna per lavabo a muro con piastre separate.

External part for wall basin mixer with separate plates.

Partie extérieure pour lavabo mural avec plaque séparées.

Außenteil für Wand-Waschtischmischer mit getrennten Platten.

Parte exterior para lavabo de pared con placas separadas.

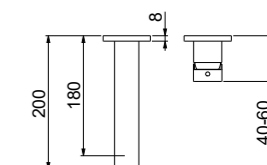
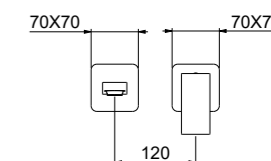

PARTE ESTERNA DA UTILIZZARE  
SOLO CON CORPO INCASSO  
**AC5005**

EXTERNAL PART TO BE USED  
ONLY WITH BUILT-IN BODY  
**AC5005**



.015 Cromo / Chrome / Chromée / Verchromt / Cromado € 143,00

.560 Nero opaco / Matt black / Noir mat / Matt Schwarz / Negro mate € 200,00

.740 Bianco opaco / Matt white / Blanc mat / Matt Weiss / Blanco mate € 200,00

Collezione Primavera € 257,00

### OR835514 \_ OMBRA

PIASTRA CON BORDO E GUARNIZIONE  
PLATE WITH RAISED EDGE AND GASKET



Parte esterna per lavabo a muro con piastre separate.

External part for wall basin mixer with separate plates.

Partie extérieure pour lavabo mural avec plaque séparées.

Außenteil für Wand-Waschtischmischer mit getrennten Platten.

Parte exterior para lavabo de pared con placas separadas.

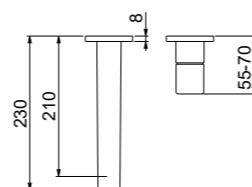
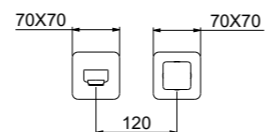

PARTE ESTERNA DA UTILIZZARE  
SOLO CON CORPO INCASSO  
**AC5005**

EXTERNAL PART TO BE USED  
ONLY WITH BUILT-IN BODY  
**AC5005**

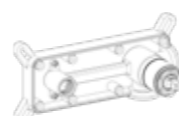

.015 Cromo / Chrome / Chromée / Verchromt / Cromado € 139,00

.560 Nero opaco / Matt black / Noir mat / Matt Schwarz / Negro mate € 195,00

Collezione Primavera € 250,00

### EL835504 \_ ELIO / ELIO SLIM

PIASTRA CON BORDO E GUARNIZIONE  
PLATE WITH RAISED EDGE AND GASKET

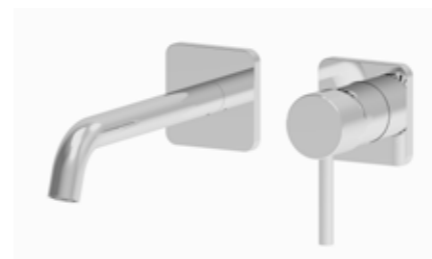

Parte esterna per lavabo a muro con piastre separate.

External part for wall basin mixer with separate plates.

Partie extérieure pour lavabo mural avec plaque séparées.

Außenteil für Wand-Waschtischmischer mit getrennten Platten.

Parte exterior para lavabo de pared con placas separadas.

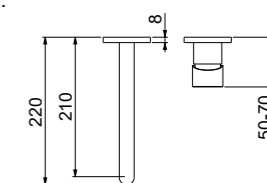
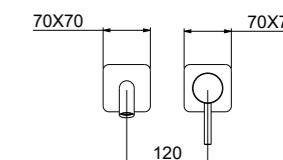

PARTE ESTERNA DA UTILIZZARE  
SOLO CON CORPO INCASSO  
**AC5005**

EXTERNAL PART TO BE USED  
ONLY WITH BUILT-IN BODY  
**AC5005**



.015 Cromo / Chrome / Chromée / Verchromt / Cromado € 134,00

.560 Nero opaco / Matt black / Noir mat / Matt Schwarz / Negro mate € 188,00

.345 Acciaio spazzolato / Brushed nickel / Acier brossé / Edelstahl Optik / Acero cepillado € 214,00

Collezione Primavera € 241,00

PARTI ESTERNE COMPLETE DI PIASTRE, LEVA,  
CAPPuccio, BOCCA E RACCORDO

EXTERNAL PARTS COMPLETE WITH PLATES, LEVER,  
CAP, SPOUT AND CONNECTION

PIASTRA SPESSORE 1 mm  
PLATE 1 mm THICK

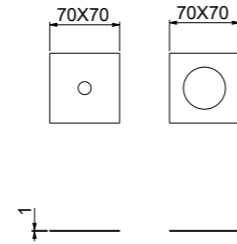
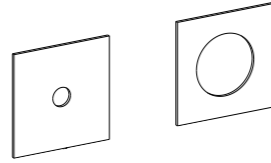

PIASTRA SPESSORE 1 mm  
PLATE 1 mm THICK

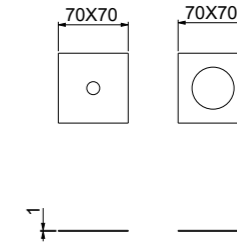
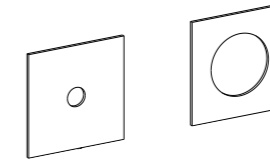

PARTI ESTERNE COMPLETE DI PIASTRE, LEVA,  
CAPPuccio, BOCCA E RACCORDO

EXTERNAL PARTS COMPLETE WITH PLATES, LEVER,  
CAP, SPOUT AND CONNECTION

### OP835512 \_ OMBRA PLUS

PIASTRA SPESSORE 1 mm  
PLATE 1 mm THICK

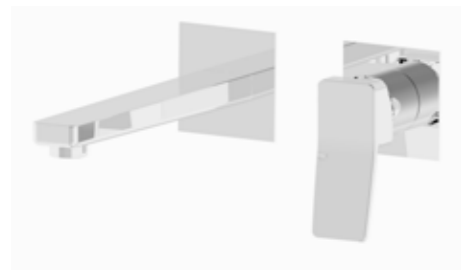

Parte esterna per lavabo a muro con piastre separate.

External part for wall basin mixer with separate plates.

Partie extérieure pour lavabo mural avec plaque séparées.

Außenteil für Wand-Waschtischmischer mit getrennten Platten.

Parte exterior para lavabo de pared con placas separadas.

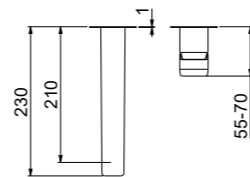
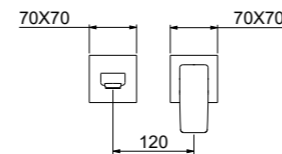

PARTE ESTERNA DA UTILIZZARE  
SOLO CON CORPO INCASSO  
**AC5005**

EXTERNAL PART TO BE USED  
ONLY WITH BUILT-IN BODY  
**AC5005**



.015 Cromo / Chrome / Chromée / Verchromt / Cromado € 142,00

.560 Nero opaco / Matt black / Noir mat / Matt Schwarz / Negro mate € 199,00

Collezione Primavera € 256,00

### PE835522 \_ PEGASO

PIASTRA SPESSORE 1 mm  
PLATE 1 mm THICK

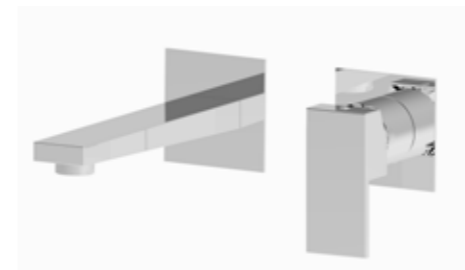

Parte esterna per lavabo a muro con piastre separate.

External part for wall basin mixer with separate plates.

Partie extérieure pour lavabo mural avec plaque séparées.

Außenteil für Wand-Waschtischmischer mit getrennten Platten.

Parte exterior para lavabo de pared con placas separadas.

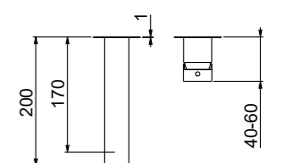
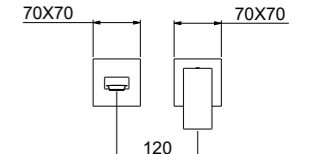

PARTE ESTERNA DA UTILIZZARE  
SOLO CON CORPO INCASSO  
**AC5005**

EXTERNAL PART TO BE USED  
ONLY WITH BUILT-IN BODY  
**AC5005**



.015 Cromo / Chrome / Chromée / Verchromt / Cromado € 146,00

.560 Nero opaco / Matt black / Noir mat / Matt Schwarz / Negro mate € 204,00

.740 Bianco opaco / Matt white / Blanc mat / Matt Weiss / Blanco mate € 204,00

Collezione Primavera € 263,00

### OR835512 \_ OMBRA

PIASTRA SPESSORE 1 mm  
PLATE 1 mm THICK



Parte esterna per lavabo a muro con piastre separate.

External part for wall basin mixer with separate plates.

Partie extérieure pour lavabo mural avec plaque séparées.

Außenteil für Wand-Waschtischmischer mit getrennten Platten.

Parte exterior para lavabo de pared con placas separadas.

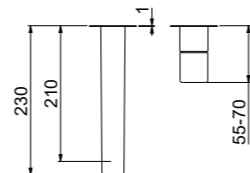
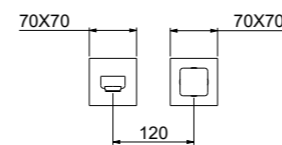

PARTE ESTERNA DA UTILIZZARE  
SOLO CON CORPO INCASSO  
**AC5005**

EXTERNAL PART TO BE USED  
ONLY WITH BUILT-IN BODY  
**AC5005**

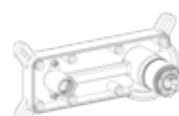

.015 Cromo / Chrome / Chromée / Verchromt / Cromado € 142,00

.560 Nero opaco / Matt black / Noir mat / Matt Schwarz / Negro mate € 199,00

Collezione Primavera € 256,00

### EL835502\_ ELIO / ELIO SLIM

PIASTRA SPESSORE 1 mm  
PLATE 1 mm THICK

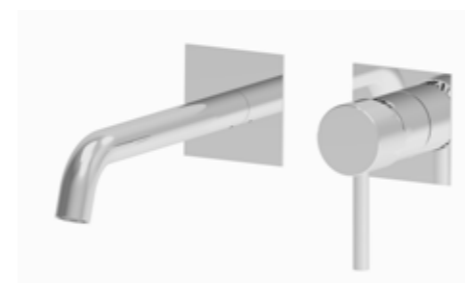

Parte esterna per lavabo a muro con piastre separate.

External part for wall basin mixer with separate plates.

Partie extérieure pour lavabo mural avec plaque séparées.

Außenteil für Wand-Waschtischmischer mit getrennten Platten.

Parte exterior para lavabo de pared con placas separadas.

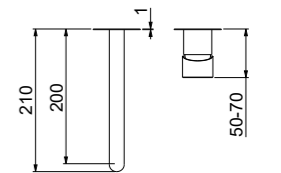
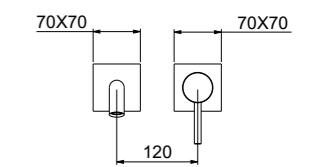

PARTE ESTERNA DA UTILIZZARE  
SOLO CON CORPO INCASSO  
**AC5005**

EXTERNAL PART TO BE USED  
ONLY WITH BUILT-IN BODY  
**AC5005**

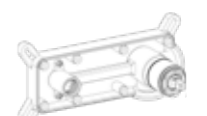

.015 Cromo / Chrome / Chromée / Verchromt / Cromado € 137,00

.560 Nero opaco / Matt black / Noir mat / Matt Schwarz / Negro mate € 192,00

.345 Acciaio spazzolato / Brushed nickel / Acier brossé / Edelstahl Optik / Acero cepillado € 219,00

Collezione Primavera € 247,00

PIASTRA CON BORDO E GUARNIZIONE  
PLATE WITH RAISED EDGE AND GASKET

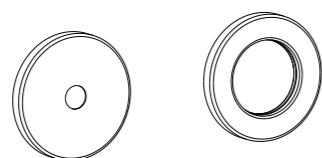

PARTI ESTERNE COMPLETE DI PIASTRE, LEVA,  
CAPPUCCIO, BOCCA E RACCORDO

EXTERNAL PARTS COMPLETE WITH PLATES, LEVER,  
CAP, SPOUT AND CONNECTION

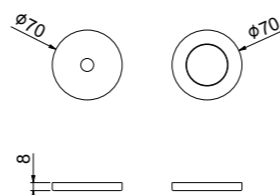

## DR835503 \_ DOREMI

PIASTRA CON BORDO E GUARNIZIONE  
PLATE WITH RAISED EDGE AND GASKET

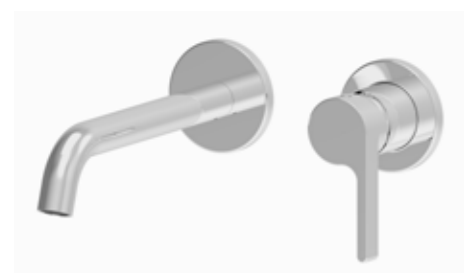

Parte esterna per lavabo a muro con piastre separate.

External part for wall basin mixer with separate plates.

Partie extérieure pour lavabo mural avec plaque séparées.

Außenteil für Wand-Waschtischmischer mit getrennten Platten.

Parte exterior para lavabo de pared con placas separadas.

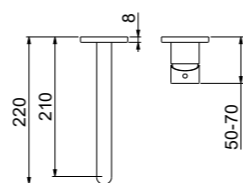
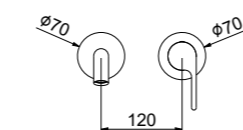

.015 Cromo / Chrome / Chromée / Verchromt / Cromado € 130,00

.560 Nero opaco / Matt black / Noir mat / Matt Schwarz / Negro mate € 182,00

.345 Acciaio spazzolato / Brushed nickel / Acier brossé / Edelstahl Optik / Acero cepillado € 208,00

Collezione Primavera € 234,00

PARTE ESTERNA DA UTILIZZARE  
SOLO CON CORPO INCASSO  
AC5005

EXTERNAL PART TO BE USED  
ONLY WITH BUILT-IN BODY  
AC5005



## EL835503 \_ ELIO / ELIO SLIM

PIASTRA CON BORDO E GUARNIZIONE  
PLATE WITH RAISED EDGE AND GASKET

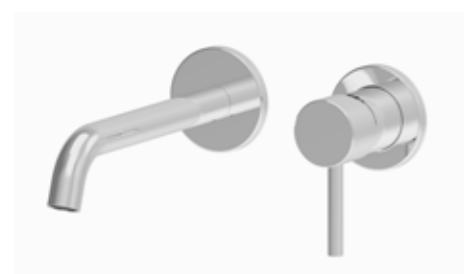

Parte esterna per lavabo a muro con piastre separate.

External part for wall basin mixer with separate plates.

Partie extérieure pour lavabo mural avec plaque séparées.

Außenteil für Wand-Waschtischmischer mit getrennten Platten.

Parte exterior para lavabo de pared con placas separadas.

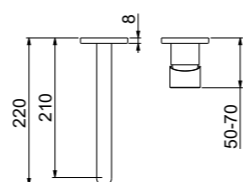
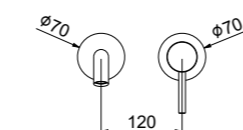

.015 Cromo / Chrome / Chromée / Verchromt / Cromado € 136,00

.560 Nero opaco / Matt black / Noir mat / Matt Schwarz / Negro mate € 190,00

.345 Acciaio spazzolato / Brushed nickel / Acier brossé / Edelstahl Optik / Acero cepillado € 218,00

Collezione Primavera € 245,00

PARTE ESTERNA DA UTILIZZARE  
SOLO CON CORPO INCASSO  
AC5005

EXTERNAL PART TO BE USED  
ONLY WITH BUILT-IN BODY  
AC5005



## OE835593 \_ OPERA MODERNA

PIASTRA CON BORDO E GUARNIZIONE  
PLATE WITH RAISED EDGE AND GASKET



Parte esterna per lavabo a muro con piastre separate.

External part for wall basin mixer with separate plates.

Partie extérieure pour lavabo mural avec plaque séparées.

Außenteil für Wand-Waschtischmischer mit getrennten Platten.

Parte exterior para lavabo de pared con placas separadas.

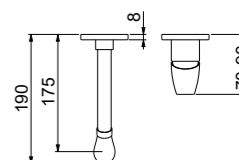
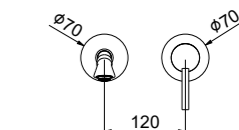

.015 Cromo / Chrome / Chromée / Verchromt / Cromado € 175,00

.560 Nero opaco / Matt black / Noir mat / Matt Schwarz / Negro mate € 245,00

PARTE ESTERNA DA UTILIZZARE  
SOLO CON CORPO INCASSO  
AC5005

EXTERNAL PART TO BE USED  
ONLY WITH BUILT-IN BODY  
AC5005

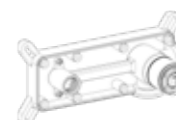

## OA835593 \_ OPERA

PIASTRA CON BORDO E GUARNIZIONE  
PLATE WITH RAISED EDGE AND GASKET

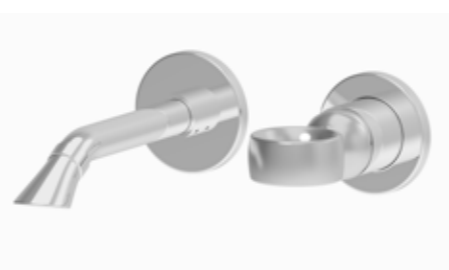

Parte esterna per lavabo a muro con piastre separate.

External part for wall basin mixer with separate plates.

Partie extérieure pour lavabo mural avec plaque séparées.

Außenteil für Wand-Waschtischmischer mit getrennten Platten.

Parte exterior para lavabo de pared con placas separadas.

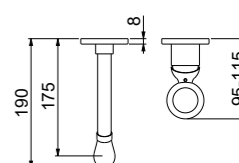
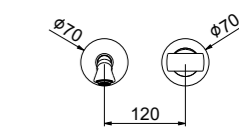

.015 Cromo / Chrome / Chromée / Verchromt / Cromado € 200,00

.560 Nero opaco / Matt black / Noir mat / Matt Schwarz / Negro mate € 280,00

.065 Bronzo / Bronze / Bronze / Bronze / Bronze € 320,00

.010 Oro / Gold / Doré / Gold / Oro € 420,00

.980 Oro rosa / Rose gold / Or rose / Rose gold / Oro rosa € 400,00

Collezione Primavera € 360,00

PARTE ESTERNA DA UTILIZZARE  
SOLO CON CORPO INCASSO  
AC5005

EXTERNAL PART TO BE USED  
ONLY WITH BUILT-IN BODY  
AC5005

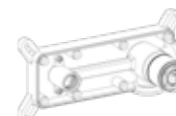

## DD835503 \_ DIADEMA

PIASTRA CON BORDO E GUARNIZIONE  
PLATE WITH RAISED EDGE AND GASKET



Parte esterna per lavabo a muro con piastre separate.

External part for wall basin mixer with separate plates.

Partie extérieure pour lavabo mural avec plaque séparées.

Außenteil für Wand-Waschtischmischer mit getrennten Platten.

Parte exterior para lavabo de pared con placas separadas.

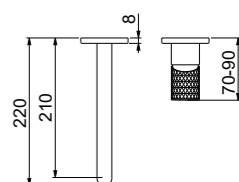
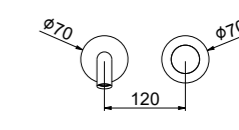

Corpo cromo / Chrome body	.015 Leva cromo / Chrome lever	€ 136,00
	.587 Leva Nero opaco / Matt black lever	€ 136,00
	.588 Leva Simil acciaio / Steel lever	€ 136,00
	.589 Leva Cromo nero / Black chrome lever	€ 136,00
	.590 Leva Grafite / Graphite lever	€ 136,00

Corpo Nero opaco / Matt black body	.591 Leva cromo / Chrome lever	€ 190,00
	.560 Leva Nero opaco / Matt black lever	€ 190,00
	.592 Leva Simil acciaio / Steel lever	€ 190,00
	.593 Leva Cromo nero / Black chrome lever	€ 190,00
	.594 Leva Grafite / Graphite lever	€ 190,00

PARTE ESTERNA DA UTILIZZARE  
SOLO CON CORPO INCASSO  
AC5005

EXTERNAL PART TO BE USED  
ONLY WITH BUILT-IN BODY  
AC5005

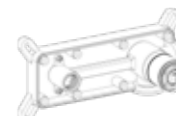

PIASTRA SPESSORE 1 mm  
PLATE 1 mm THICK

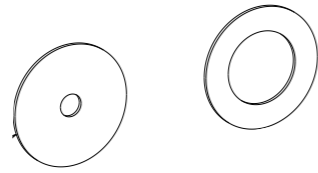

PARTI ESTERNE COMPLETE DI PIASTRE, LEVA,  
CAPPUCCIO, BOCCA E RACCORDO

EXTERNAL PARTS COMPLETE WITH PLATES, LEVER,  
CAP, SPOUT AND CONNECTION

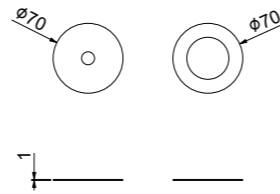

## DR835501 \_ DOREMI

PIASTRA SPESSORE 1 mm  
PLATE 1 mm THICK

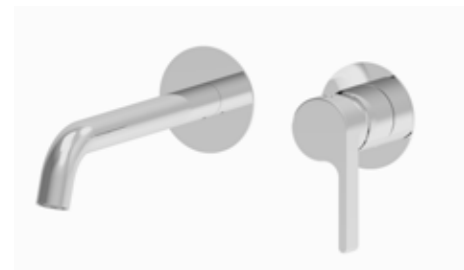

Parte esterna per lavabo a muro con piastre separate.

External part for wall basin mixer with separate plates.

Partie extérieure pour lavabo mural avec plaque séparées.

Außenteil für Wand-Waschtischmischer mit getrennten Platten.

Parte exterior para lavabo de pared con placas separadas.

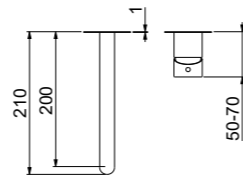
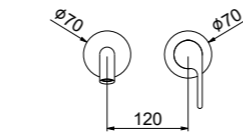

.015 Cromo / Chrome / Chromée / Verchromt / Cromado € 133,00

.560 Nero opaco / Matt black / Noir mat / Matt Schwarz / Negro mate € 186,00

.345 Acciaio spazzolato / Brushed nickel / Acier brossé / Edelstahl Optik / Acero cepillado € 213,00

Collezione Primavera € 239,00

PARTE ESTERNA DA UTILIZZARE SOLO CON CORPO INCASSO AC5005

EXTERNAL PART TO BE USED ONLY WITH BUILT-IN BODY AC5005



## EL835501 \_ ELIO / ELIO SLIM

PIASTRA SPESSORE 1 mm  
PLATE 1 mm THICK



Parte esterna per lavabo a muro con piastre separate.

External part for wall basin mixer with separate plates.

Partie extérieure pour lavabo mural avec plaque séparées.

Außenteil für Wand-Waschtischmischer mit getrennten Platten.

Parte exterior para lavabo de pared con placas separadas.

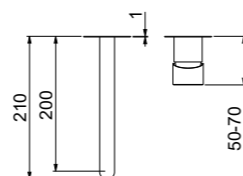
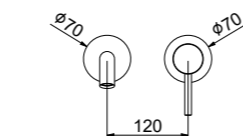

.015 Cromo / Chrome / Chromée / Verchromt / Cromado € 139,00

.560 Nero opaco / Matt black / Noir mat / Matt Schwarz / Negro mate € 195,00

.345 Acciaio spazzolato / Brushed nickel / Acier brossé / Edelstahl Optik / Acero cepillado € 222,00

Collezione Primavera € 250,00

PARTE ESTERNA DA UTILIZZARE SOLO CON CORPO INCASSO AC5005

EXTERNAL PART TO BE USED ONLY WITH BUILT-IN BODY AC5005

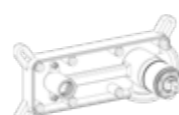

## OE835591 \_ OPERA MODERNA

PIASTRA SPESSORE 1 mm  
PLATE 1 mm THICK

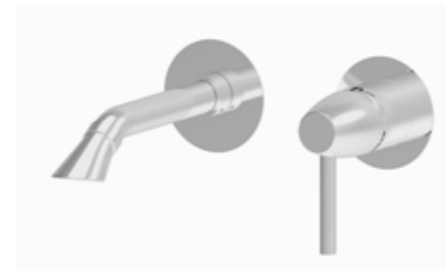

Parte esterna per lavabo a muro con piastre separate.

External part for wall basin mixer with separate plates.

Partie extérieure pour lavabo mural avec plaque séparées.

Außenteil für Wand-Waschtischmischer mit getrennten Platten.

Parte exterior para lavabo de pared con placas separadas.

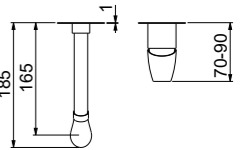
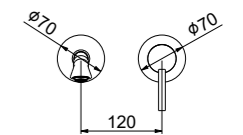

.015 Cromo / Chrome / Chromée / Verchromt / Cromado € 178,00

.560 Nero opaco / Matt black / Noir mat / Matt Schwarz / Negro mate € 249,00

PARTE ESTERNA DA UTILIZZARE SOLO CON CORPO INCASSO AC5005

EXTERNAL PART TO BE USED ONLY WITH BUILT-IN BODY AC5005

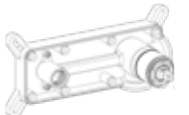

## OA835591 \_ OPERA

PIASTRA SPESSORE 1 mm  
PLATE 1 mm THICK

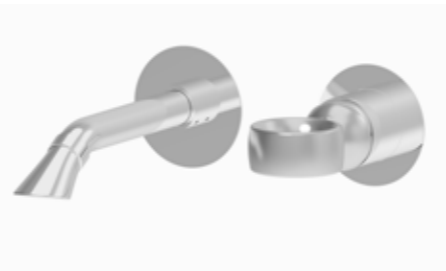

Parte esterna per lavabo a muro con piastre separate.

External part for wall basin mixer with separate plates.

Partie extérieure pour lavabo mural avec plaque séparées.

Außenteil für Wand-Waschtischmischer mit getrennten Platten.

Parte exterior para lavabo de pared con placas separadas.

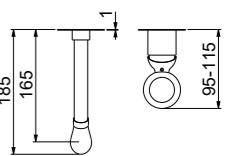
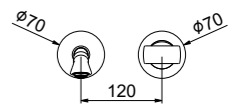

.015 Cromo / Chrome / Chromée / Verchromt / Cromado € 203,00

.560 Nero opaco / Matt black / Noir mat / Matt Schwarz / Negro mate € 284,00

.065 Bronzo / Bronze / Bronze / Bronze / Bronze € 325,00

.010 Oro / Gold / Doré / Gold / Oro € 406,00

.980 Oro rosa / Rose gold / Or rose / Rose gold / Oro rosa € 426,00

Collezione Primavera € 365,00

PARTE ESTERNA DA UTILIZZARE SOLO CON CORPO INCASSO AC5005

EXTERNAL PART TO BE USED ONLY WITH BUILT-IN BODY AC5005

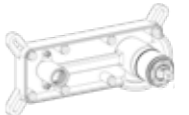

## DD835501 \_ DIADEMA

PIASTRA SPESSORE 1 mm  
PLATE 1 mm THICK

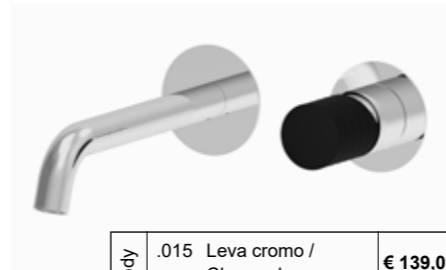

Parte esterna per lavabo a muro con piastre separate.

External part for wall basin mixer with separate plates.

Partie extérieure pour lavabo mural avec plaque séparées.

Außenteil für Wand-Waschtischmischer mit getrennten Platten.

Parte exterior para lavabo de pared con placas separadas.

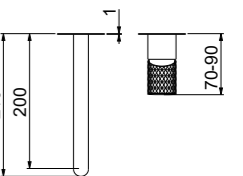
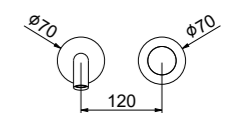

Corpo cromo / Chrome body	.015 Leva cromo / Chrome lever	€ 139,00
	.587 Leva Nero opaco / Matt black lever	€ 139,00
	.588 Leva Simil acciaio / Steel lever	€ 139,00
	.589 Leva Cromo nero / Black chrome lever	€ 139,00
	.590 Leva Grafite / Graphite lever	€ 139,00

Corpo Nero opaco / Matt black body	.591 Leva cromo / Chrome lever	€ 195,00
	.560 Leva Nero opaco / Matt black lever	€ 195,00
	.592 Leva Simil acciaio / Steel lever	€ 195,00
	.593 Leva Cromo nero / Black chrome lever	€ 195,00
	.594 Leva Grafite / Graphite lever	€ 195,00

PARTE ESTERNA DA UTILIZZARE SOLO CON CORPO INCASSO AC5005

EXTERNAL PART TO BE USED ONLY WITH BUILT-IN BODY AC5005

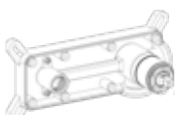

## AC1208

Cappuccio EASY COVER.

EASY COVER cap.

Capuchon EASY COVER.

Abdeckkappe EASY COVER.

Capucha EASY COVER.



.015	Cromo / Chrome / Chromée / Verchromt / Cromado	€ 20,00
.560	Nero opaco / Matt black / Noir mat / Matt Schwarz / Negro mate	€ 28,00
.740	Bianco opaco / Matt white / Blanc mat / Matt Weiss	€ 28,00
	Acciaio spazzolato / Brushed nickel / Acier brossé /	€ 32,00
.345	Edelstahl Optik / Acero cepillado	
.065	Bronzo / Bronze / Bronze / Bronze / Bronze	€ 32,00
.010	Oro / Gold / Doré / Gold / Oro	€ 40,00
.980	Oro rosa / Rose gold / Or rose / Rose gold / Oro rosa	€ 42,00
	Collezione Primavera	€ 36,00

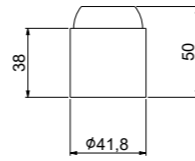

## AC5104

Piastra per doccia incasso 1 uscita con bordo e guarnizione.

Plate for 1-way built-in shower mixer with raised edge and gasket.

Plaque pour douche à encastrer 1 sortie avec bord et joint.

Platte für 1-Weg Unterputz Duschkörper mit erhöhtem Rand und Dichtung.

Placa para ducha empotrable 1 salida con borde y sello.

.015	Cromo / Chrome / Chromée / Verchromt / Cromado	€ 16,00
.560	Nero opaco / Matt black / Noir mat / Matt Schwarz / Negro mate	€ 22,00
.740	Bianco opaco / Matt white / Blanc mat / Matt Weiss	€ 22,00
	Acciaio spazzolato / Brushed nickel / Acier brossé /	€ 26,00
.345	Edelstahl Optik / Acero cepillado	
.065	Bronzo / Bronze / Bronze / Bronze / Bronze	€ 26,00
.010	Oro / Gold / Doré / Gold / Oro	€ 32,00
.980	Oro rosa / Rose gold / Or rose / Rose gold / Oro rosa	€ 34,00
	Collezione Primavera	€ 29,00

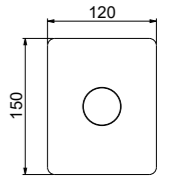

## AC1209

Canotto deviatore 2/3 vie.

Diverter cover 2-3 outlets.

Canot Cache-inverseur 2-3 sorties.

Abdeckkappe für Umsteller 2-3 Wege.

Tija cubre-inversor 2-3 salidas.



.015	Cromo / Chrome / Chromée / Verchromt / Cromado	€ 13,00
.560	Nero opaco / Matt black / Noir mat / Matt Schwarz / Negro mate	€ 18,00
.740	Bianco opaco / Matt white / Blanc mat / Matt Weiss	€ 18,00
	Acciaio spazzolato / Brushed nickel / Acier brossé /	€ 21,00
.345	Edelstahl Optik / Acero cepillado	
.065	Bronzo / Bronze / Bronze / Bronze / Bronze	€ 21,00
.010	Oro / Gold / Doré / Gold / Oro	€ 26,00
.980	Oro rosa / Rose gold / Or rose / Rose gold / Oro rosa	€ 27,00
	Collezione Primavera	€ 23,00

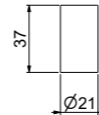

## AC5102

Piastra per doccia incasso 1 uscita spessore 1 mm.

Plate for 1-way built-in shower mixer 1 mm thick.

Plaque pour douche à encastrer 1 sortie épaisseur 1 mm.

Platte für 1-Weg Unterputz Duschkörper, Dicke 1 mm.

Placa para ducha empotrable 1 salida espesor 1 mm.

.015	Cromo / Chrome / Chromée / Verchromt / Cromado	€ 25,00
.560	Nero opaco / Matt black / Noir mat / Matt Schwarz / Negro mate	€ 35,00
.740	Bianco opaco / Matt white / Blanc mat / Matt Weiss	€ 35,00
	Acciaio spazzolato / Brushed nickel / Acier brossé /	€ 40,00
.345	Edelstahl Optik / Acero cepillado	
.065	Bronzo / Bronze / Bronze / Bronze / Bronze	€ 40,00
.010	Oro / Gold / Doré / Gold / Oro	€ 50,00
.980	Oro rosa / Rose gold / Or rose / Rose gold / Oro rosa	€ 53,00
	Collezione Primavera	€ 45,00

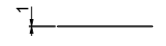
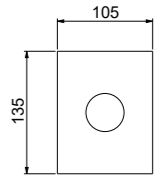

## AC1217

Maniglia deviatore 2/3 vie.

Diverter handle 2-3 outlets.

Manette d'inversion 2-3 sorties.

Umstellergriff 2-3 Wege.

Maneta de inversión 2-3 salidas.

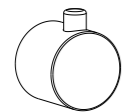

.015	Cromo / Chrome / Chromée / Verchromt / Cromado	€ 32,00
.560	Nero opaco / Matt black / Noir mat / Matt Schwarz / Negro mate	€ 45,00
.740	Bianco opaco / Matt white / Blanc mat / Matt Weiss	€ 45,00
	Acciaio spazzolato / Brushed nickel / Acier brossé /	€ 51,00
.345	Edelstahl Optik / Acero cepillado	
.065	Bronzo / Bronze / Bronze / Bronze / Bronze	€ 51,00
.010	Oro / Gold / Doré / Gold / Oro	€ 64,00
.980	Oro rosa / Rose gold / Or rose / Rose gold / Oro rosa	€ 67,00
	Collezione Primavera	€ 58,00

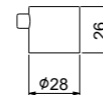

## AC5103

Piastra per doccia incasso 1 uscita con bordo e guarnizione.

Plate for 1-way built-in shower mixer with raised edge and gasket.

Plaque pour douche à encastrer 1 sortie avec bord et joint.

Platte für 1-Weg Unterputz Duschkörper mit erhöhtem Rand und Dichtung.

Placa para ducha empotrable 1 salida con borde y sello.

.015	Cromo / Chrome / Chromée / Verchromt / Cromado	€ 18,00
.560	Nero opaco / Matt black / Noir mat / Matt Schwarz / Negro mate	€ 25,00
.740	Bianco opaco / Matt white / Blanc mat / Matt Weiss	€ 25,00
	Acciaio spazzolato / Brushed nickel / Acier brossé /	€ 29,00
.345	Edelstahl Optik / Acero cepillado	
.065	Bronzo / Bronze / Bronze / Bronze / Bronze	€ 29,00
.010	Oro / Gold / Doré / Gold / Oro	€ 36,00
.980	Oro rosa / Rose gold / Or rose / Rose gold / Oro rosa	€ 38,00
	Collezione Primavera	€ 32,00

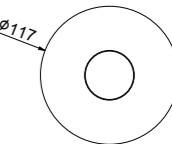

## AC1218

Maniglia deviatore 2/3 vie.

Diverter handle 2-3 outlets.

Manette d'inversion 2-3 sorties.

Umstellergriff 2-3 Wege.

Maneta de inversión 2-3 salidas.



.015	Cromo / Chrome / Chromée / Verchromt / Cromado	€ 34,00
.560	Nero opaco / Matt black / Noir mat / Matt Schwarz / Negro mate	€ 48,00
.740	Bianco opaco / Matt white / Blanc mat / Matt Weiss	€ 48,00
	Acciaio spazzolato / Brushed nickel / Acier brossé /	€ 54,00
.345	Edelstahl Optik / Acero cepillado	
.065	Bronzo / Bronze / Bronze / Bronze / Bronze	€ 54,00
.010	Oro / Gold / Doré / Gold / Oro	€ 68,00
.980	Oro rosa / Rose gold / Or rose / Rose gold / Oro rosa	€ 71,00
	Collezione Primavera	€ 61,00



## AC5101

Piastra per doccia incasso 1 uscita spessore 1 mm.

Plate for 1-way built-in shower mixer 1 mm thick.

Plaque pour douche à encastrer 1 sortie épaisseur 1 mm.

Platte für 1-Weg Unterputz Duschkörper, Dicke 1 mm.

Placa para ducha empotrable 1 salida espesor 1 mm.

.015	Cromo / Chrome / Chromée / Verchromt / Cromado	€ 27,00
.560	Nero opaco / Matt black / Noir mat / Matt Schwarz / Negro mate	€ 38,00
.740	Bianco opaco / Matt white / Blanc mat / Matt Weiss	€ 38,00
	Acciaio spazzolato / Brushed nickel / Acier brossé /	€ 43,00
.345	Edelstahl Optik / Acero cepillado	
.065	Bronzo / Bronze / Bronze / Bronze / Bronze	€ 43,00
.010	Oro / Gold / Doré / Gold / Oro	€ 54,00
.980	Oro rosa / Rose gold / Or rose / Rose gold / Oro rosa	€ 57,00
	Collezione Primavera	€ 49,00

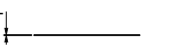
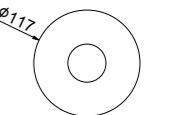

## AC5204

Piastra per doccia incasso 2-3 uscite con bordo e guarnizione.

Plate for 2 or 3-way built-in shower mixer with raised edge and gasket.

Plaque pour douche à encastrer 2-3 sorties avec bord et joint.

Platte für 2-3 Wege Unterputz Duschkörper mit erhöhtem Rand und Dichtung.

Placa para ducha empotrable 2-3 salidas con borde y sello.

.015	Cromo / Chrome / Chromée / Verchromt / Cromado	€ 26,00
.560	Nero opaco / Matt black / Noir mat / Matt Schwarz / Negro mate	€ 36,00
.740	Bianco opaco / Matt white / Blanc mat / Matt Weiss	€ 36,00
	Acciaio spazzolato / Brushed nickel / Acier brossé /	€ 42,00
.345	Edelstahl Optik / Acero cepillado	
.065	Bronzo / Bronze / Bronze / Bronze / Bronze	€ 42,00
.010	Oro / Gold / Doré / Gold / Oro	€ 52,00
.980	Oro rosa / Rose gold / Or rose / Rose gold / Oro rosa	€ 55,00
	Collezione Primavera	€ 47,00

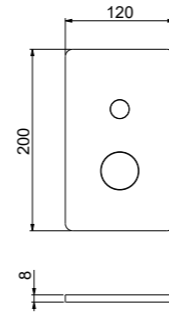

## AC5404

Piastra per lavabo a muro con bordo e guarnizione.

Plate for wall basin mixer with raised edge and gasket.

Plaque pour lavabo mural avec bord et joint.

Platte für Wand-Waschtischmischer mit erhöhtem Rand und Dichtung.

Placa para lavabo de pared con borde y sello.

.015	Cromo / Chrome / Chromée / Verchromt / Cromado	€ 30,00
.560	Nero opaco / Matt black / Noir mat / Matt Schwarz / Negro mate	€ 42,00
.740	Bianco opaco / Matt white / Blanc mat / Matt Weiss	€ 42,00
	Acciaio spazzolato / Brushed nickel / Acier brossé /	€ 48,00
.345	Edelstahl Optik / Acero cepillado	
.065	Bronzo / Bronze / Bronze / Bronze / Bronze	€ 48,00
.010	Oro / Gold / Doré / Gold / Oro	€ 60,00
.980	Oro rosa / Rose gold / Or rose / Rose gold / Oro rosa	€ 63,00
	Collezione Primavera	€ 54,00

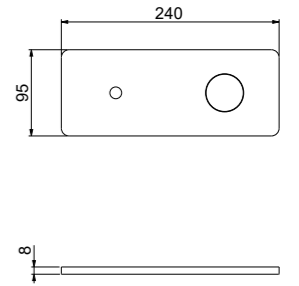

## AC5202

Piastra per doccia incasso 2-3 uscite spessore 1 mm.

Plate for 2 or 3-way built-in shower mixer 1 mm thick.

Plaque pour douche à encastrer 2-3 sorties épaisseur 1 mm.

Platte für 2-3 Wege Unterputz Duschkörper, Dicke 1 mm

Placa para ducha empotrable 2-3 salidas espesor 1 mm.

.015	Cromo / Chrome / Chromée / Verchromt / Cromado	€ 28,00
.560	Nero opaco / Matt black / Noir mat / Matt Schwarz / Negro mate	€ 39,00
.740	Bianco opaco / Matt white / Blanc mat / Matt Weiss	€ 39,00
	Acciaio spazzolato / Brushed nickel / Acier brossé /	€ 45,00
.345	Edelstahl Optik / Acero cepillado	
.065	Bronzo / Bronze / Bronze / Bronze / Bronze	€ 45,00
.010	Oro / Gold / Doré / Gold / Oro	€ 56,00
.980	Oro rosa / Rose gold / Or rose / Rose gold / Oro rosa	€ 59,00
	Collezione Primavera	€ 50,00

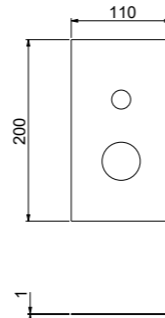

## AC5402

Piastra per lavabo a muro spessore 1 mm.

Plate for wall basin mixer 1 mm thick.

Plaque pour lavabo mural épaisseur 1 mm.

Platte für Wand-Waschtischmischer, Dicke 1 mm.

Placa para lavabo de pared espesor 1 mm.

.015	Cromo / Chrome / Chromée / Verchromt / Cromado	€ 33,00
.560	Nero opaco / Matt black / Noir mat / Matt Schwarz / Negro mate	€ 46,00
.740	Bianco opaco / Matt white / Blanc mat / Matt Weiss	€ 46,00
	Acciaio spazzolato / Brushed nickel / Acier brossé /	€ 53,00
.345	Edelstahl Optik / Acero cepillado	
.065	Bronzo / Bronze / Bronze / Bronze / Bronze	€ 53,00
.010	Oro / Gold / Doré / Gold / Oro	€ 66,00
.980	Oro rosa / Rose gold / Or rose / Rose gold / Oro rosa	€ 69,00
	Collezione Primavera	€ 59,00

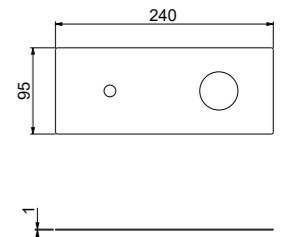

## AC5203

Piastra per doccia incasso 2-3 uscite con bordo e guarnizione.

Plate for 2 or 3-way built-in shower mixer with raised edge and gasket.

Plaque pour douche à encastrer 2-3 sorties avec bord et joint.

Platte für 2-3 Wege Unterputz Duschkörper mit erhöhtem Rand und Dichtung.

Placa para ducha empotrable 2-3 salidas con borde y sello.

.015	Cromo / Chrome / Chromée / Verchromt / Cromado	€ 22,00
.560	Nero opaco / Matt black / Noir mat / Matt Schwarz / Negro mate	€ 31,00
.740	Bianco opaco / Matt white / Blanc mat / Matt Weiss	€ 31,00
	Acciaio spazzolato / Brushed nickel / Acier brossé /	€ 35,00
.345	Edelstahl Optik / Acero cepillado	
.065	Bronzo / Bronze / Bronze / Bronze / Bronze	€ 35,00
.010	Oro / Gold / Doré / Gold / Oro	€ 44,00
.980	Oro rosa / Rose gold / Or rose / Rose gold / Oro rosa	€ 46,00
	Collezione Primavera	€ 40,00

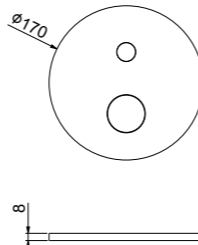

## AC5401

Piastra per lavabo a muro spessore 1 mm.

Plate for wall basin mixer 1 mm thick.

Plaque pour lavabo mural épaisseur 1 mm.

Platte für Wand-Waschtischmischer, Dicke 1 mm.

Placa para lavabo de pared espesor 1 mm.

.015	Cromo / Chrome / Chromée / Verchromt / Cromado	€ 36,00
.560	Nero opaco / Matt black / Noir mat / Matt Schwarz / Negro mate	€ 50,00
.740	Bianco opaco / Matt white / Blanc mat / Matt Weiss	€ 50,00
	Acciaio spazzolato / Brushed nickel / Acier brossé /	€ 58,00
.345	Edelstahl Optik / Acero cepillado	
.065	Bronzo / Bronze / Bronze / Bronze / Bronze	€ 58,00
.010	Oro / Gold / Doré / Gold / Oro	€ 72,00
.980	Oro rosa / Rose gold / Or rose / Rose gold / Oro rosa	€ 76,00
	Collezione Primavera	€ 65,00

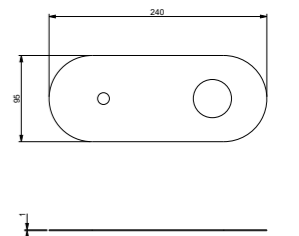

## AC5201

Piastra per doccia incasso 2-3 uscite spessore 1 mm.

Plate for 2 or 3-way built-in shower mixer 1 mm thick.

Plaque pour douche à encastrer 2-3 sorties épaisseur 1 mm.

Platte für 2-3 Wege Unterputz Duschkörper, Dicke 1 mm

Placa para ducha empotrable 2-3 salidas espesor 1 mm.

.015	Cromo / Chrome / Chromée / Verchromt / Cromado	€ 30,00
.560	Nero opaco / Matt black / Noir mat / Matt Schwarz / Negro mate	€ 42,00
.740	Bianco opaco / Matt white / Blanc mat / Matt Weiss	€ 42,00
	Acciaio spazzolato / Brushed nickel / Acier brossé /	€ 48,00
.345	Edelstahl Optik / Acero cepillado	
.065	Bronzo / Bronze / Bronze / Bronze / Bronze	€ 48,00
.010	Oro / Gold / Doré / Gold / Oro	€ 60,00
.980	Oro rosa / Rose gold / Or rose / Rose gold / Oro rosa	€ 63,00
	Collezione Primavera	€ 54,00

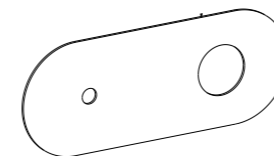
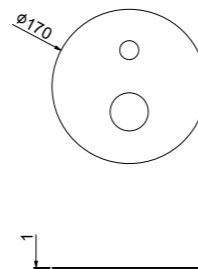

## AC5504

Piastre per lavabo a muro con bordo e guarnizione.

Plates for wall basin mixer with raised edge and gasket.

Plaques pour lavabo mural avec bord et joint.

Platten für Wand-Waschtischmischer mit erhöhtem Rand und Dichtung.

Placas para lavabo de pared con borde y sello.

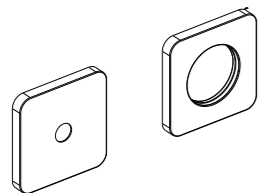

.015	Cromo / Chrome / Chromée / Verchromt / Cromado	€ 32,00
.560	Nero opaco / Matt black / Noir mat / Matt Schwarz / Negro mate	€ 45,00
.740	Bianco opaco / Matt white / Blanc mat / Matt Weiss	€ 45,00
	Acciaio spazzolato / Brushed nickel / Acier brossé /	€ 51,00
.345	Edelstahl Optik / Acero cepillado	
.065	Bronzo / Bronze / Bronze / Bronze / Bronze	€ 51,00
.010	Oro / Gold / Doré / Gold / Oro	€ 64,00
.980	Oro rosa / Rose gold / Or rose / Rose gold / Oro rosa	€ 67,00
	Collezione Primavera	€ 58,00

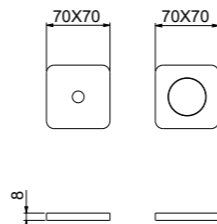

## AC5502

Piastre per lavabo a muro spessore 1 mm.

Plates for wall basin mixer 1 mm thick.

Plaques pour lavabo mural épaisseur 1 mm.

Platten für Wand-Waschtischmischer, Dicke 1 mm.

Placas para lavabo de pared espesor 1 mm.

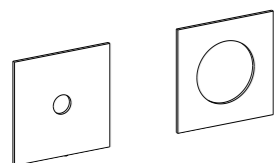

.015	Cromo / Chrome / Chromée / Verchromt / Cromado	€ 35,00
.560	Nero opaco / Matt black / Noir mat / Matt Schwarz / Negro mate	€ 49,00
.740	Bianco opaco / Matt white / Blanc mat / Matt Weiss	€ 49,00
	Acciaio spazzolato / Brushed nickel / Acier brossé /	€ 56,00
.345	Edelstahl Optik / Acero cepillado	
.065	Bronzo / Bronze / Bronze / Bronze / Bronze	€ 56,00
.010	Oro / Gold / Doré / Gold / Oro	€ 70,00
.980	Oro rosa / Rose gold / Or rose / Rose gold / Oro rosa	€ 73,00
	Collezione Primavera	€ 63,00

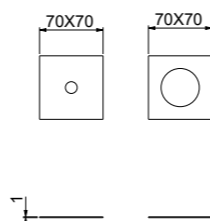

## AC5503

Piastre per lavabo a muro con bordo e guarnizione.

Plates for wall basin mixer with raised edge and gasket.

Plaques pour lavabo mural avec bord et joint.

Platten für Wand-Waschtischmischer mit erhöhtem Rand und Dichtung.

Placas para lavabo de pared con borde y sello.



.015	Cromo / Chrome / Chromée / Verchromt / Cromado	€ 34,00
.560	Nero opaco / Matt black / Noir mat / Matt Schwarz / Negro mate	€ 48,00
.740	Bianco opaco / Matt white / Blanc mat / Matt Weiss	€ 48,00
	Acciaio spazzolato / Brushed nickel / Acier brossé /	€ 54,00
.345	Edelstahl Optik / Acero cepillado	
.065	Bronzo / Bronze / Bronze / Bronze / Bronze	€ 54,00
.010	Oro / Gold / Doré / Gold / Oro	€ 68,00
.980	Oro rosa / Rose gold / Or rose / Rose gold / Oro rosa	€ 71,00
	Collezione Primavera	€ 61,00

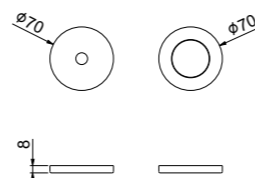

## AC5501

Piastre per lavabo a muro spessore 1 mm.

Plates for wall basin mixer 1 mm thick.

Plaques pour lavabo mural épaisseur 1 mm.

Platten für Wand-Waschtischmischer, Dicke 1 mm.

Placas para lavabo de pared espesor 1 mm.

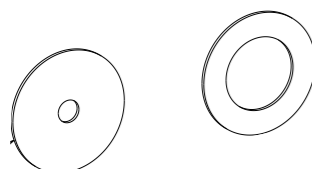

.015	Cromo / Chrome / Chromée / Verchromt / Cromado	€ 37,00
.560	Nero opaco / Matt black / Noir mat / Matt Schwarz / Negro mate	€ 52,00
.740	Bianco opaco / Matt white / Blanc mat / Matt Weiss	€ 52,00
	Acciaio spazzolato / Brushed nickel / Acier brossé /	€ 59,00
.345	Edelstahl Optik / Acero cepillado	
.065	Bronzo / Bronze / Bronze / Bronze / Bronze	€ 59,00
.010	Oro / Gold / Doré / Gold / Oro	€ 74,00
.980	Oro rosa / Rose gold / Or rose / Rose gold / Oro rosa	€ 78,00
	Collezione Primavera	€ 67,00

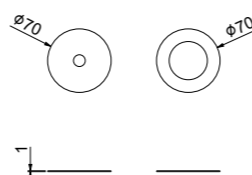

## AC5509

Bocca Elio per lavabo a muro.

Elio spout for wall basin mixer.

Bec Elio pour lavabo mural.

Elio Auslauf für Wand-Waschtischmischer.

Caño Elio para lavabo de pared.

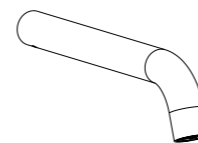

.015	Cromo / Chrome / Chromée / Verchromt / Cromado	€ 60,00
.560	Nero opaco / Matt black / Noir mat / Matt Schwarz / Negro mate	€ 84,00
.740	Bianco opaco / Matt white / Blanc mat / Matt Weiss	€ 84,00
	Acciaio spazzolato / Brushed nickel / Acier brossé /	€ 96,00
.345	Edelstahl Optik / Acero cepillado	
.065	Bronzo / Bronze / Bronze / Bronze / Bronze	€ 96,00
.010	Oro / Gold / Doré / Gold / Oro	€ 120,00
.980	Oro rosa / Rose gold / Or rose / Rose gold / Oro rosa	€ 126,00
	Collezione Primavera	€ 108,00

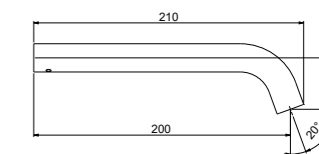

BOCCA FORNITA CON RACCORDO  
SPOUT SUPPLIED WITH CONNECTION

## AC5519

Bocca Ombra per lavabo a muro.

Ombra spout for wall basin mixer.

Bec Ombra pour lavabo mural.

Ombra Auslauf für Wand-Waschtischmischer.

Caño Ombra para lavabo de pared.

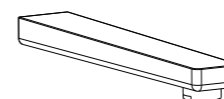

.015	Cromo / Chrome / Chromée / Verchromt / Cromado	€ 76,00
.560	Nero opaco / Matt black / Noir mat / Matt Schwarz / Negro mate	€ 106,00
.740	Bianco opaco / Matt white / Blanc mat / Matt Weiss	€ 106,00
	Acciaio spazzolato / Brushed nickel / Acier brossé /	€ 122,00
.345	Edelstahl Optik / Acero cepillado	
.065	Bronzo / Bronze / Bronze / Bronze / Bronze	€ 122,00
.010	Oro / Gold / Doré / Gold / Oro	€ 152,00
.980	Oro rosa / Rose gold / Or rose / Rose gold / Oro rosa	€ 160,00
	Collezione Primavera	€ 137,00

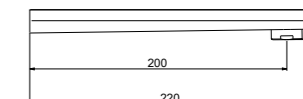

BOCCA FORNITA CON RACCORDO  
SPOUT SUPPLIED WITH CONNECTION

## AC5529

Bocca Pegaso per lavabo a muro.

Pegaso spout for wall basin mixer.

Bec Pegaso pour lavabo mural.

Pegaso Auslauf für Wand-Waschtischmischer.

Caño Pegaso para lavabo de pared.

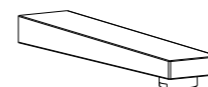

.015	Cromo / Chrome / Chromée / Verchromt / Cromado	€ 76,00
.560	Nero opaco / Matt black / Noir mat / Matt Schwarz / Negro mate	€ 106,00
.740	Bianco opaco / Matt white / Blanc mat / Matt Weiss	€ 106,00
	Acciaio spazzolato / Brushed nickel / Acier brossé /	€ 122,00
.345	Edelstahl Optik / Acero cepillado	
.065	Bronzo / Bronze / Bronze / Bronze / Bronze	€ 122,00
.010	Oro / Gold / Doré / Gold / Oro	€ 152,00
.980	Oro rosa / Rose gold / Or rose / Rose gold / Oro rosa	€ 160,00
	Collezione Primavera	€ 137,00

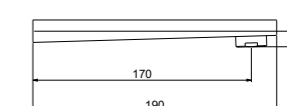

BOCCA FORNITA CON RACCORDO  
SPOUT SUPPLIED WITH CONNECTION

## AC5599

Bocca Opera per lavabo a muro.

Opera spout for wall basin mixer.

Bec Opera pour lavabo mural.

Opera Auslauf für Wand-Waschtischmischer.

Caño Opera para lavabo de pared.

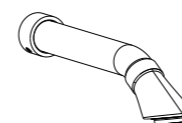

.015	Cromo / Chrome / Chromée / Verchromt / Cromado	€ 96,00
.560	Nero opaco / Matt black / Noir mat / Matt Schwarz / Negro mate	€ 134,00
.740	Bianco opaco / Matt white / Blanc mat / Matt Weiss	€ 134,00
	Blanco mate	
.345	Acciaio spazzolato / Brushed nickel / Acier brossé /	€ 154,00
	Edelstahl Optik / Acero cepillado	
.065	Bronzo / Bronze / Bronze / Bronze / Bronze	€ 154,00
.010	Oro / Gold / Doré / Gold / Oro	€ 192,00
.980	Oro rosa / Rose gold / Or rose / Rose gold / Oro rosa	€ 202,00
	Collezione Primavera	€ 173,00



BOCCA FORNITA CON RACCORDO  
SPOUT SUPPLIED WITH CONNECTION

## AC0780

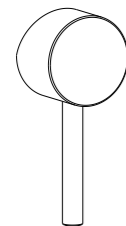

Leva Elio/Elio Slim.

Elio/Elio Slim lever.

Manette Elio/Elio Slim.

Elio Griff.

Maneta Elio.

.015 Cromo / Chrome / Chromée / Verchromt / Cromado € 22,00

.560 Nero opaco / Matt black / Noir mat / Matt Schwarz / Negro mate € 31,00

.345 Acciaio spazzolato / Brushed nickel / Acier brossé / Edelstahl Optik / Acero cepillado € 35,00

Collezione Primavera € 40,00

LEVA PER CARTUCCIA Ø35 mm

LEVER FOR CARTRIDGE Ø35 mm

## AC0985



Leva Opera.

Opera lever.

Manette Opera.

Opera Griff.

Maneta Opera.

.015 Cromo / Chrome / Chromée / Verchromt / Cromado € 50,00

.560 Nero opaco / Matt black / Noir mat / Matt Schwarz / Negro mate € 70,00

.065 Bronzo / Bronze / Bronze / Bronze / Bronze € 80,00

.010 Oro / Gold / Doré / Gold / Oro € 100,00

.980 Oro rosa / Rose gold / Or rose / Rose gold / Oro rosa € 105,00

Collezione Primavera € 90,00

LEVA PER CARTUCCIA Ø35 mm

LEVER FOR CARTRIDGE Ø35 mm

## AC0986

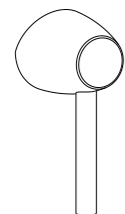

Leva Opera Moderna.

Opera Moderna lever.

Manette Opera Moderna.

Opera Moderna Griff.

Maneta Opera Moderna.

.015 Cromo / Chrome / Chromée / Verchromt / Cromado € 25,00

.560 Nero opaco / Matt black / Noir mat / Matt Schwarz / Negro mate € 35,00

LEVA PER CARTUCCIA Ø35 mm

LEVER FOR CARTRIDGE Ø35 mm

## AC1087

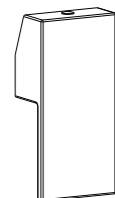

Leva Pegaso.

Pegaso lever.

Manette Pegaso.

Pegaso Griff.

Maneta Pegaso.

.015 Cromo / Chrome / Chromée / Verchromt / Cromado € 15,00

.560 Nero opaco / Matt black / Noir mat / Matt Schwarz / Negro mate € 21,00

.740 Bianco opaco / Matt white / Blanc mat / Matt Weiss € 21,00

Collezione Primavera € 27,00

LEVA PER CARTUCCIA Ø35 mm

LEVER FOR CARTRIDGE Ø35 mm

## AC1169

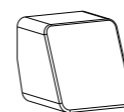

Leva Ombra.

Ombra lever.

Manette Ombra.

Ombra Griff.

Maneta Ombra.

.015 Cromo / Chrome / Chromée / Verchromt / Cromado € 11,00

.560 Nero opaco / Matt black / Noir mat / Matt Schwarz / Negro mate € 15,00

Collezione Primavera € 20,00

LEVA PER CARTUCCIA Ø35 mm

LEVER FOR CARTRIDGE Ø35 mm

## AC1181



Leva Ombra Plus.

Ombra Plus lever.

Manette Ombra Plus.

Ombra Plus Griff.

Maneta Ombra Plus.

.015 Cromo / Chrome / Chromée / Verchromt / Cromado € 11,00

.560 Nero opaco / Matt black / Noir mat / Matt Schwarz / Negro mate € 15,00

Collezione Primavera € 20,00

LEVA PER CARTUCCIA Ø35 mm

LEVER FOR CARTRIDGE Ø35 mm

## AC1012

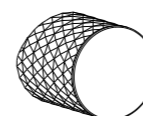

Leva Diadema.

Diadema lever.

Manette Diadema.

Diadema Griff.

Maneta Diadema.

Leva cromo / Chrome lever	€ 22,00
Leva Nero opaco / Matt black lever	€ 22,00
Leva Simil acciaio / Steel lever	€ 22,00
Leva Cromo nero / Black chrome lever	€ 22,00
Leva Grafite / Graphite lever	€ 22,00

LEVA PER CARTUCCIA Ø35 mm

LEVER FOR CARTRIDGE Ø35 mm

## AC0987

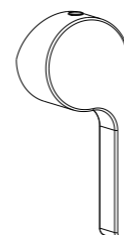

Leva Doremi.

Doremi lever.

Manette Doremi.

Doremi Griff.

Maneta Doremi.

.015 Cromo / Chrome / Chromée / Verchromt / Cromado € 16,00

.560 Nero opaco / Matt black / Noir mat / Matt Schwarz / Negro mate € 22,00

.345 Acciaio spazzolato / Brushed nickel / Acier brossé / Edelstahl Optik / Acero cepillado € 26,00

Collezione Primavera € 29,00

LEVA PER CARTUCCIA Ø35 mm

LEVER FOR CARTRIDGE Ø35 mm

# SHOWER SET



EL971402.015  
Termostatico incasso a parete.  
Thrmostatic concealed mixer.

ACO984.845  
Soffione in acciaio inox.  
Shiny stainless steel shower head.



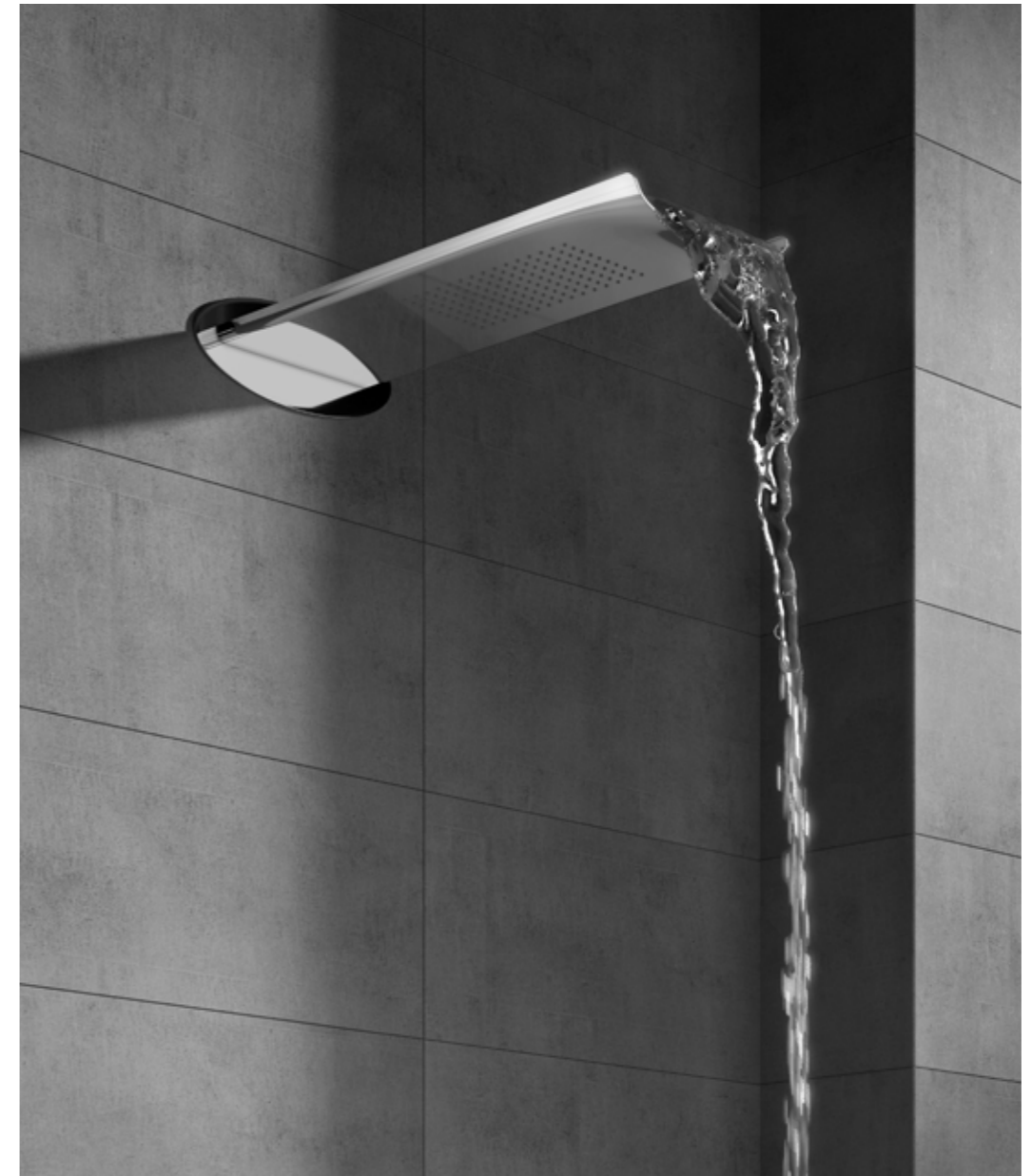

WO660302  
Colonna doccia esterna.  
External column with shower mixer.



AC0741.845  
Soffione multifunzione.  
Multifunction shower head.

## WO660302

 Kg 15,2  
 Box pcs 1

Colonna doccia esterna, con miscelatore monocomando con deviatore, flessibile, supporto, doccetta e soffione anticalcare.

External column with shower mixer, diverter, flexible hose, holder, handshower and antiscald showerhead.

Colonne de douche avec inverseur, flexible, support, douchette et pomme de douche anticalcaire.

Brausebatterie mit Gleitstange, Umsteller, Brauseschlauch, Wandhalterung, Handbrause und Contra Kalk Metall Fester-Kopfbrause.

Column de ducha monomando completa de desviador, tubo flexible, soporte, ducha y rociador anticaliza.

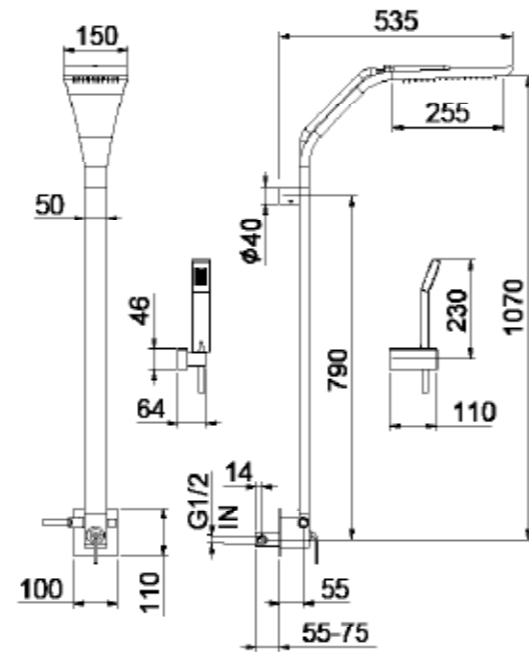

- |      |   |            |
|------|---|------------|
| .015 | Cromo / Chrome / Chromée / Verchromt / Cromado  | € 2.210,00 |
| .564 | Nero opaco-Cromo / Matt black-Chrome / Noir mat-Chromée / Schwarz matt-Chrom / Negro mate-Cromado | € 2.450,00 |

 Ø 35 mm  
AC0312000

## EL980509

Box pcs. 1

  Kg 6,8

  Kg 3,2

Miscelatore termostatico per doccia esterno, versione completa di colonna, soffione Ø250 mm e doccetta multifunzione.

Thermostatic shower mixer with column, Ø250 mm shower head and multifunction handshower.

Colonne de douche thermostatique avec colonne, pomme de douche Ø250 mm et douchette multijet.

Thermostat Brausebatterie mit Brausegleitstange, Brausekopf Ø250 mm und Massagehandbrause.

Column de ducha termostática, versión con columna, rociador Ø250 mm y ducha masaje.

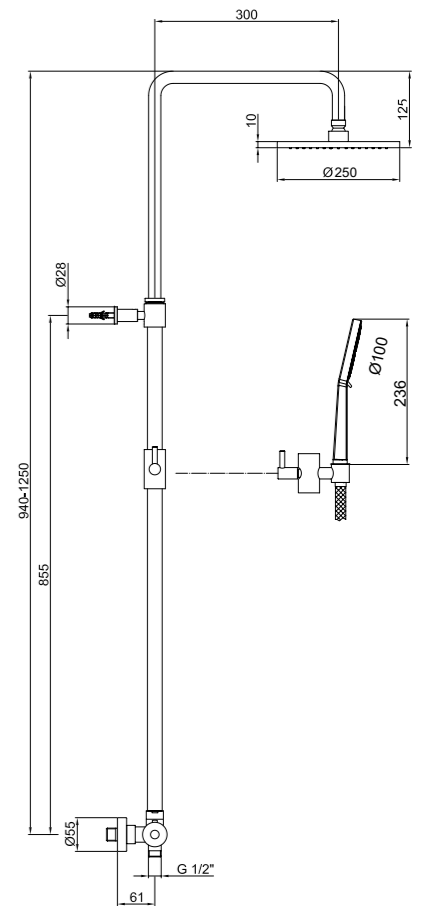
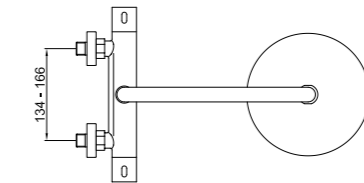

- |       |      |  |          |
|-------|------|--|----------|
| STEEL | .015 | Cromo / Chrome / Chromée / Verchromt / Cromado                 | € 595,00 |
| BRASS | .560 | Nero opaco / Matt black / Noir mat / Schwarz matt / Negro mate | € 850,00 |
| BRASS |      | Color Lab  | € 868,00 |

## EL980507

Box pcs. 1

  Kg 6,8

  Kg 3,2



Miscelatore termostatico per doccia esterno, versione completa di colonna, soffione Ø200 mm e doccetta monogetto.

Thermostatic shower mixer with column, Ø200 mm shower head and monospray handshower.

Colonne de douche thermostatique avec colonne, pomme de douche Ø200 mm et douchette monojet.

Thermostat Brausebatterie mit Brausegleitstange, Brausekopf Ø200 mm und 1 Funktion Handbrause.

Columna de ducha termostática, versión con columna, rociador Ø200 mm y ducha.

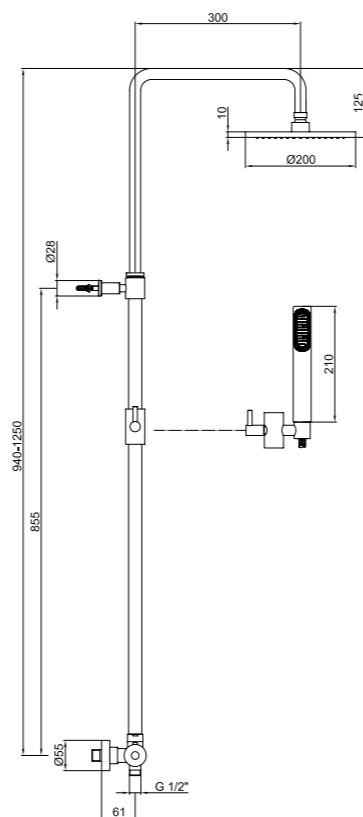
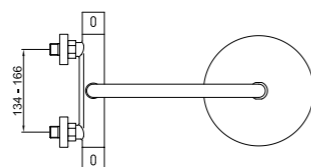

PVC	.015	Cromo / Chrome / Chromée / Verchromt / Cromado	€ 463,00
STEEL	.015	Cromo / Chrome / Chromée / Verchromt / Cromado	€ 541,00
BRASS	.560	Nero opaco / Matt black / Noir mat / Matt Schwarz / Negro mate	€ 789,00
BRASS	.345	Acciaio spazzolato / Brushed nickel / Acier brossé / Edelstahl Optik / Acero cepillado	€ 960,00

## EL870105

Box pcs. 1

  Kg 6,8

  Kg 3,2



Miscelatore monocomando per doccia esterno, versione completa di colonna, soffione Ø200 mm e doccetta monogetto.

Shower mixer with column, Ø200 mm shower head and monospray handshower.

Mitigeur de douche avec colonne, pomme de douche Ø200 mm et douchette monojet.

Einhebemischer Brausebatterie mit Brausegleitstange, Brausekopf Ø200 mm und 1 Funktion Handbrause.

Monomando externo para ducha, versión con columna, rociador Ø200 mm y ducha.

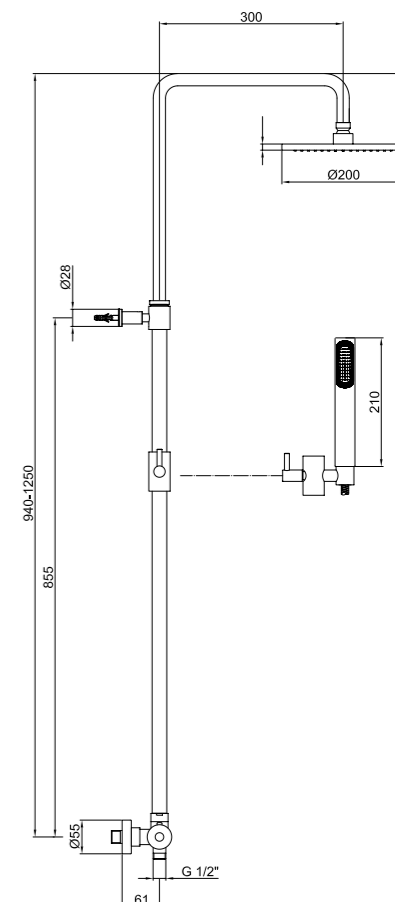
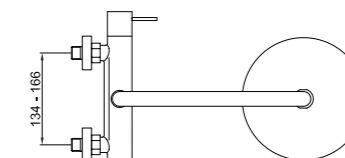



PVC	.015	Cromo / Chrome / Chromée / Verchromt / Cromado	€ 511,00
STEEL	.015	Cromo / Chrome / Chromée / Verchromt / Cromado	€ 586,00

## EL980510

Box pcs. 1

  Kg 5,8

  Kg 3,2



Miscelatore termostatico per doccia esterno, versione con colonna e flessibile.

Thermostatic shower mixer with column and flexible.

Colonne de douche thermostatique avec colonne et flexible.

Thermostat Brausebatterie mit Brausegleitstange und Brauseschlauch.

Columna de ducha termostática, versión con columna y flexible.

Da abbinare con soffioni a pag. 323-324-325 e doccette a pag. 317-319.  
To be combined with shower heads on p. 323-324-325 and hand showers on p. 317-319.  
À assortir avec les pommeaux à la page 323-324-325 et les douchettes à la page 317-319.  
Mit Kopfbrausen auf Seite 323-324-325 und Handbrausen auf Seite 317-319 zu kombinieren.  
De combinar con rociadores a la pág. 323-324-325 et las duchas de mano a la pág. 317-319

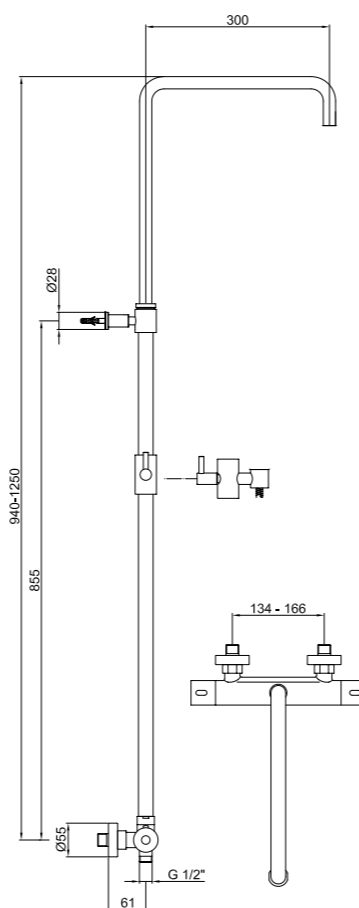



.015	Cromo / Chrome / Chromée / Verchromt / Cromado	€ 351,00
.560	Nero opaco / Matt black / Noir mat / Matt Schwarz / Negro mate	€ 498,00
.345	Acciaio spazzolato / Brushed nickel / Acier brossé / Edelstahl Optik / Acero cepillado	€ 607,00
Collezione Primavera		€ 607,00

## EL870605

Box pcs. 1

  Kg 5,8

  Kg 3,2



Miscelatore monocomando per doccia esterno con deviatore incorporato, versione completa di colonna, soffione Ø200 mm e doccetta monogetto.

Shower mixer with integrated diverter, column, Ø200 mm shower head and monospray handshower.

Mitigeur de douche avec inverseur intégré, colonne, pomme de douche Ø200 mm et douchette monojet.

Einhebemischer Brausebatterie mit Brausegleitstange, Brausekopf Ø200 mm und 1 Funktion Handbrause.

Monomando externo para ducha, versión con columna, rociador Ø200 mm y ducha.

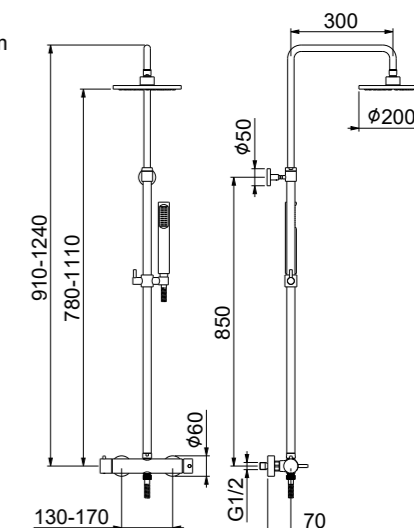

STEEL	.015	Cromo / Chrome / Chromée / Verchromt / Cromado	€ 493,00
STEEL	.560	Nero opaco / Matt black / Noir mat / Matt Schwarz / Negro mate	€ 720,00
STEEL	.345	Acciaio spazzolato / Brushed nickel / Acier brossé / Edelstahl Optik / Acero cepillado	€ 930,00
STEEL	Collezione Primavera		€ 930,00

	EL870625 Ø250 mm	EL870630 Ø300 mm
STEEL .015	€ 540,00	€ 572,00
STEEL .560	€ 796,00	€ 874,00
STEEL .345	€ 1.032,00	€ 1.215,00
STEEL	€ 1.032,00	€ 1.215,00

## AA980507

Box pcs. 1

  Kg 6,8

  Kg 2,4



Miscelatore termostatico per doccia esterno, versione completa di colonna, soffione e doccetta monogetto.

Thermostatic shower mixer with column, shower head and monospray handshower.

Colonne de douche thermostatique avec colonne, pomme de douche et douchette monojet.

Thermostat Brausebatterie mit Brausegleitstange, Brausekopf und 1 Funktion Handbrause.

Column de ducha termostática, versión con columna, rociador y ducha.

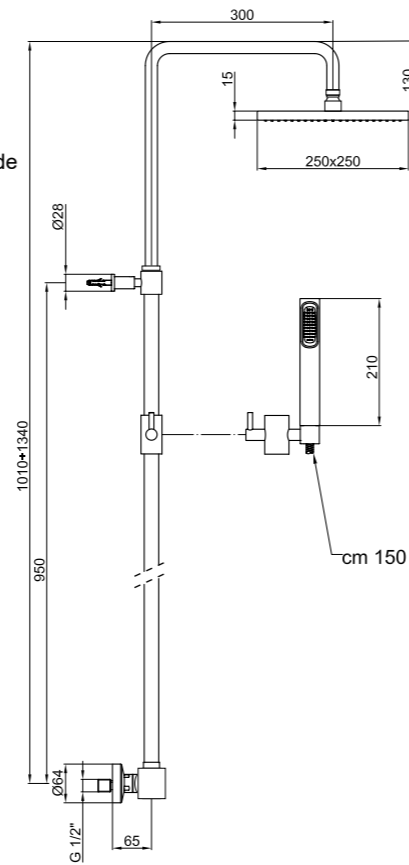
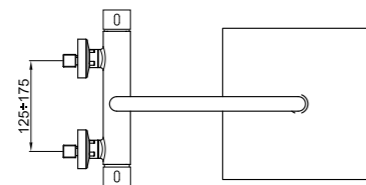

PVC .015	Cromo / Chrome / Chromée / Verchromt / Cromado	€ 605,00
STEEL .015	Cromo / Chrome / Chromée / Verchromt / Cromado	€ 680,00
BRASS .560	Nero opaco / Matt black / Noir mat / Matt Schwarz / Negro mate	€ 885,00

## AZ870110

Box pcs. 1

  Kg 6,8

  Kg 3,2



Miscelatore monocomando per doccia esterno, versione completa di colonna, soffione e doccetta monogetto.

Shower mixer with column, shower head and monospray handshower.

Mitigeur de douche avec colonne, pomme de douche et douchette monojet.

Einhebelmischer Brausebatterie mit Brausegleitstange, Brausekopf und 1 Funktion Handbrause.

Monomando externo para ducha, versión con columna, rociador y ducha.

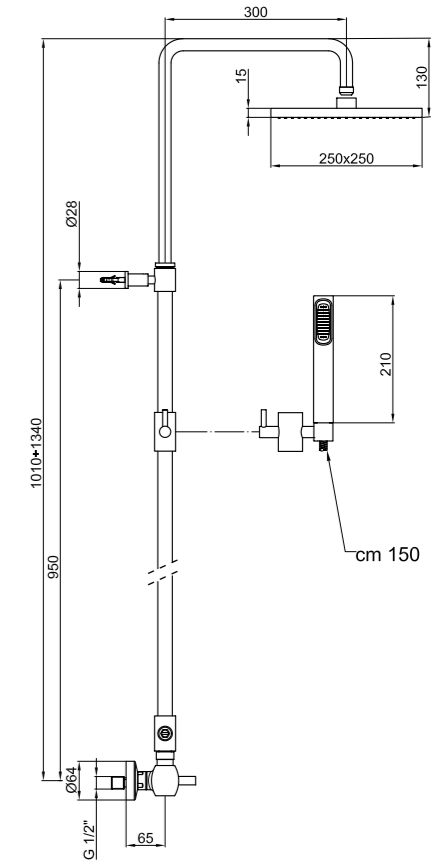
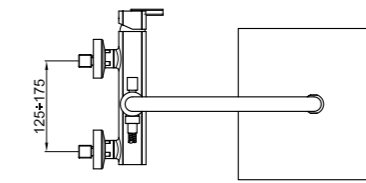

PVC .015	Cromo / Chrome / Chromée / Verchromt / Cromado	€ 557,00
BRASS .015	Cromo / Chrome / Chromée / Verchromt / Cromado	€ 664,00

## AA980510

Box pcs. 1

  Kg 5,8

  Kg 3,2



Miscelatore termostatico per doccia esterno, versione con colonna e flessibile.

Thermostatic shower mixer with column and flexible.

Colonne de douche thermostatique avec colonne et flexible.

Thermostat Brausebatterie mit Brausegleitstange und Brauseschlauch.

Column de ducha termostática, versión con columna y flexible.

Da abbinare con soffioni a pag. 323-324-325 e doccette a pag. 317-319.  
To be combined with shower heads on p. 323-324-325 and hand showers on p. 317-319.  
À assortir avec les pommeaux à la page 323-324-325 et les douchettes à la page 317-319.  
Mit Kopfbrausen auf Seite 323-324-325 und Handbrausen auf Seite 317-319 zu kombinieren.  
De combinar con rociadores a la pág. 323-324-325 et las duchas de mano a la pág. 317-319

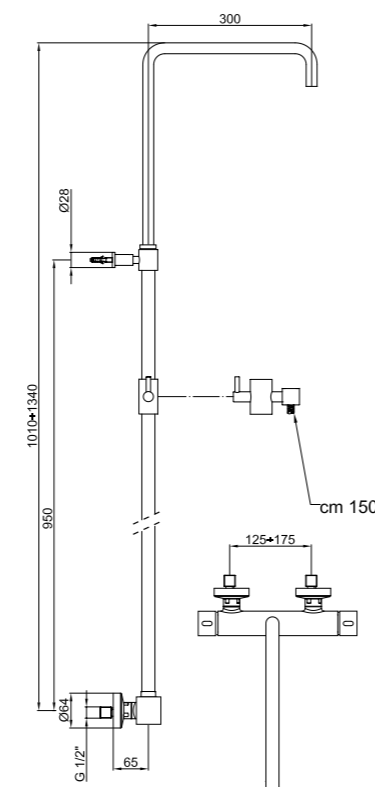

.015	Cromo / Chrome / Chromée / Verchromt / Cromado	€ 442,00
------	--	----------

## PE870605

Box pcs. 1

 Kg 10



Miscelatore monocomando per doccia esterno con deviatore incorporato, versione completa di colonna, soffione 250x250 mm in acciaio e doccetta monogetto.

Shower mixer with integrated diverter, column, 250x250 mm stainless steel shower head and monospray handshower.

Mitigeur de douche avec inverseur intégré, colonne, pomme de douche 250x250 mm en acier et douchette monojet.

Externer Duschkocher mit Umsteller, Duschsäule, 250x250 mm Duschkopf und Einstrahl-Handbrause.

Mezclador monomando externo para ducha con desviador integrado, versión completa de columna, rociador 250x250 mm y ducha un chorro.

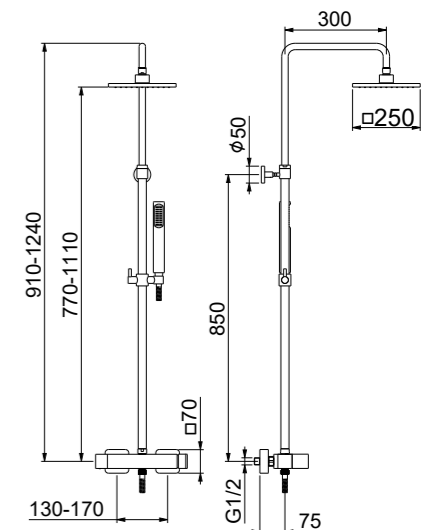

STEEL .015	Cromo / Chrome / Chromée / Verchromt / Cromado	€ 585,00
STEEL .560	Nero opaco / Matt black / Noir mat / Matt Schwarz / Negro mate	€ 860,00
STEEL .345	Acciaio spazzolato / Brushed nickel / Acier brossé / Edelstahl Optik / Acero cepillado	€ 1.099,00
STEEL	Collezione Primavera	€ 1.099,00

PE870630 300x300 mm
€ 600,00
€ 974,00
€ 1.125,00
€ 1.125,00

**AC1123**

Box pcs. 1

Kg 6



Colonna doccia esterna con supporto, deviatore e flessibile.

External shower column with holder, diverter and flexible.

Colonne de douche avec support, inverseur et flexible.

Duschsäule mit Kopfbrause, 1 Funktion Handbrause und Gleithalterung.

Column ducha con soporte, desviador y flexible.

Da abbinare con soffioni a pag. 323-324-325 e doccette a pag.317-319.  
To be combined with shower heads on p. 323-324-325 and hand showers on p. 317-319.  
À assortir avec les pommeaux à la page 323-324-325 et les douchettes à la page 317-319.  
Mit Kopfbrausen auf Seite 323-324-325 und Handbrausen auf Seite 317-319 zu kombinieren.  
De combinar con rociadores a la pàg. 323-324-325 et las duchas de mano a la pàg. 317-319

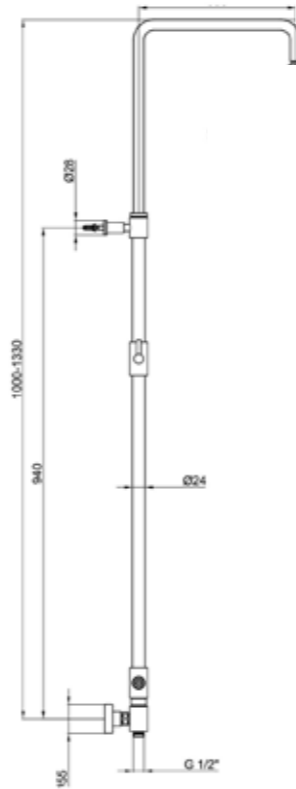

.015 Cromo / Chrome / Chromée / Verchromt / Cromado € 298,00

**EL980102**

Box pcs. 8

Kg 3,2



Miscelatore termostatico per doccia esterno, senza flessibile, doccetta e gancio di supporto.

Thermostatic shower mixer without shower set.

Mitigeur thermostatique douche sans garniture de douche.

Thermostat Brausebatterie ohne Brausegarnitur.

Mezclador termostatico externo para ducha, sin tubo flexible, ducha, ni soporte.

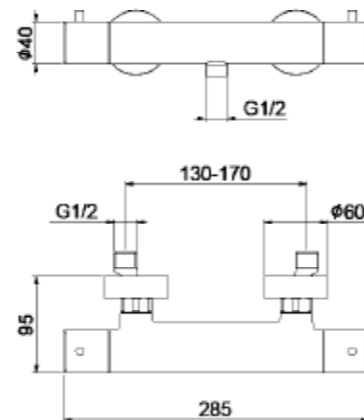

.015 Cromo / Chrome / Chromée / Verchromt / Cromado € 195,00  
.560 Nero opaco / Matt black / Noir mat / Matt Schwarz / Negro mate € 273,00  
.345 Acciaio spazzolato / Brushed nickel / Acier brossé / Edelstahl Optik / Acero cepillado € 312,00

**EL980502**

Box pcs. 8

Kg 3,2



Miscelatore termostatico per doccia esterno con attacco colonna, senza flessibile, doccetta e gancio di supporto.

Thermostatic shower mixer without shower set.

Mitigeur thermostatique douche sans garniture de douche.

Thermostat Brausebatterie ohne Brausegarnitur.

Mezclador termostatico externo para ducha, sin tubo flexible, rociador, ni soporte.

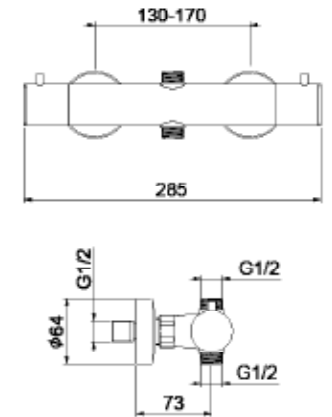

.015 Cromo / Chrome / Chromée / Verchromt / Cromado € 198,00  
.560 Nero opaco / Matt black / Noir mat / Matt Schwarz / Negro mate € 277,00  
.345 Acciaio spazzolato / Brushed nickel / Acier brossé / Edelstahl Optik / Acero cepillado € 317,00

**AC0344**

Box pcs. 12

Kg 0,2



Curva da incasso per presa acqua, attacchi da 1/2" M.

Wall elbow 1/2" M connection.

Coude de sortie, attache 1/2" M.

Unterputz-Anschlusswinkel 1/2" M.

Curva de encastré para toma de agua, juntas de 1/2" M.

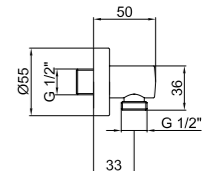

.015 Cromo / Chrome / Chromée / Verchromt / Cromado € 22,00  
.010 Oro / Gold / Doré Gold / Oro € 44,00  
.065 Bronzato / Bronze / Bronze / Bronze / Bronze € 40,00  
.560 Nero opaco / Matt black / Noir mat / Schwarz matt / Negro mate € 31,00

**AC0478**

Box pcs. 12

Kg 0,2



Curva da incasso per presa acqua, attacchi da 1/2" M.

Wall elbow 1/2" M connection.

Coude de sortie, attache 1/2" M.

Unterputz-Anschlusswinkel 1/2" M.

Curva de encastre para toma de agua, juntas de 1/2" M.

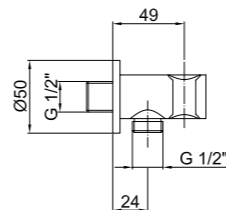

.015 Cromo / Chrome / Chromée / Verchromt / Cromado € 48,00

.560 Nero opaco / Matt black / Noir mat / Schwarz matt / Negro mate € 67,00

.010 Oro / Gold / Doré Gold / Oro € 96,00

**AC0354**

Box pcs. 12

Kg 0,2



Curva da incasso per presa acqua, attacchi da 1/2" M.

Wall elbow 1/2" M connection.

Coude de sortie, attache 1/2" M.

Unterputz-Anschlusswinkel 1/2" M.

Curva de encastre para toma de agua, juntas de 1/2" M.

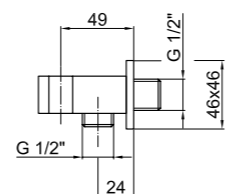

.015 Cromo / Chrome / Chromée / Verchromt / Cromado € 52,00

.560 Nero opaco / Matt black / Noir mat / Schwarz matt / Negro mate € 104,00

**AC0337**

Box pcs. 12

Kg 0,2



Curva da incasso per presa acqua quadrata, attacchi da 1/2" M.

Wall elbow 1/2" M connection.

Coude de sortie, attache 1/2" M.

Unterputz-Anschlusswinkel 1/2" M.

Curva de encastre para toma de agua, juntas de 1/2" M.

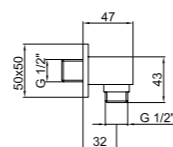

.015 Cromo / Chrome / Chromée / Verchromt / Cromado € 38,00

.560 Nero opaco / Matt black / Noir mat / Schwarz matt / Negro mate € 53,00

**AC1058**

Box pcs. 12

Kg 0,2



Gancio duplex.

Shower holder.

Support mural.

Wandhalterung.

Soporte.

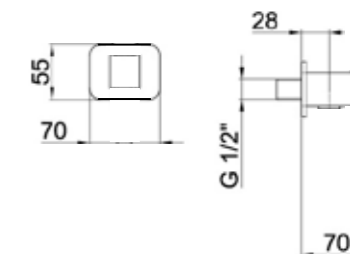

.015 Cromo / Chrome / Chromée / Verchromt / Cromado € 80,00

.560 Nero opaco / Matt black / Noir mat / Matt Schwarz / Negro mate € 112,00

**AC0295**

Box pcs. 12

Kg 0,2



Presse d'acqua.

Intake of water.

Prise d'eau.

Unterputz-Anschlusswinkel.

Toma de agua.

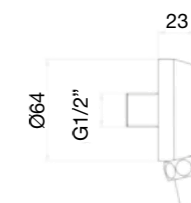

.015 Cromo / Chrome / Chromée / Verchromt / Cromado € 15,00

**AC1131**

Box pcs. 12

Kg 0,2



Supporto fisso.

Wall holder.

Support mural.

Wandhalterung.

Soporte.



.015 Cromo / Chrome / Chromée / Verchromt / Cromado € 4,00

.560 Nero opaco / Mat black / Noir mat / Matt Schwarz / Negro mate € 6,00

**AC0437**

Box pcs. 12

Kg 0,2



Gancio duplex con snodo.

Shower holder with ball joint.

Support mural avec rotule.

Wandhalterung mit Gelenkstück.

Soporte orientable.

.015 Cromo / Chrome / Chromée / Verchromt / Cromado € 19,00

**AC0438**

Box pcs. 12

Kg 0,2



Gancio duplex con snodo.  
Shower holder with ball joint.  
Support mural avec rotule.  
Wandhalterung mit Gelenkstück.  
Soporte orientable.

.015 Cromo / Chrome / Chromée / Verchromt / Cromado € 24,00

**AC0439**

Box pcs. 12

Kg 0,2



Gancio duplex in ottone con snodo.  
Brass Shower holder with ball joint.  
Support mural métallique avec rotule.  
Metall Wandhalterung mit Gelenkstück.  
Soporte de latón orientable.

.015 Cromo / Chrome / Chromée / Verchromt / Cromado € 20,00  
.010 Oro / Gold / Doré / Gold / Oro € 40,00  
.017 Cromo-Oro / Chrome-Gold / Chromé-Or / Chrom-Gold / Cromo-Oro € 23,00  
.065 Bronzato / Bronze / Bronze / Bronze / Bronze € 36,00

**AC0442**

Box pcs. 12

Kg 0,2



Flessibile in ottone cm 150 attacco conico da 1/2" F.  
Metal hose cm 150 conic/knurled, 1/2".  
Flexible métallique cm 150, écrou conique 1/2".  
Metall-Brauseschlauch cm. 150, 1/2".  
Tubo flexible de latón, longitud 150 cm, conexión cónica de 1/2" F.

.015 Cromo / Chrome / Chromée / Verchromt / Cromado € 11,00  
.010 Oro / Gold / Doré / Gold / Oro € 55,00  
.017 Cromo-Oro / Chrome-Gold / Chromé-Or / Chrom-Gold / Cromo-Oro € 23,00  
.065 Bronzato / Bronze / Bronze / Bronze / Bronze € 31,00

**AC0333**

Box pcs. 12

Kg 0,3



Soffioncino laterale quadro con limitatore portata 6 l/min.  
Lateral squared body jet with 6l/min flow rate.  
Jet latéral carré avec limiteur de débit 6 l/min.  
Seitliche eckige Düse mit 6l/min Wassermengebegrenzer.  
Ducha lateral cuadrada con limitador de caudal 6 l/min.

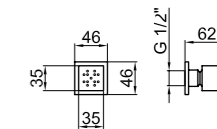

.015 Cromo / Chrome / Chromée / Verchromt / Cromado € 105,00

**AC0320**

Box pcs. 12

Kg 0,3



Soffioncino laterale cilindrico con limitatore portata 6 l/min.  
Lateral cylindrical body jet with 6l/min flow rate.  
Jet latéral cylindrique avec limiteur de débit 6 l/min.  
Seitliche zylindrische Düse mit 6l/min Wassermengebegrenzer.  
Ducha lateral cilíndrica con limitador de caudal 6 l/min.

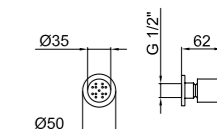

.015 Cromo / Chrome / Chromée / Verchromt / Cromado € 77,00

**AC1126**

Box pcs. 12

Kg 0,3



Soffioncino Body Spray quadrato 100x100 mm.  
Square body spray shower jet 100x100 mm.  
Jet "Body Spray" carré 100x100 mm.  
Seitliche Düse 100x100 mm.  
Ducha lateral 100x100 mm.

.015 Cromo / Chrome / Chromée / Verchromt / Cromado € 47,00  
.010 Oro / Gold / Doré / Gold / Oro € 94,00  
.560 Nero opaco / Matt black / Noir mat / Matt Schwarz / Negro mate € 66,00  
.345 Acciaio spazzolato / Brushed nickel / Acier brossé / Edelstahl Optik / Acero cepillado € 75,00  
Collezione Primavera € 110,00

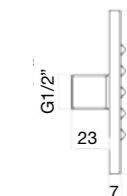
**AC1127**

Box pcs. 12

Kg 0,3



Soffioncino Body Spray quadrato Ø100 mm.  
Square body spray shower jet Ø100 mm.  
Jet "Body Spray" carré Ø100 mm.  
Seitliche Düse Ø100 mm.  
Ducha lateral Ø100 mm.

.015 Cromo / Chrome / Chromée / Verchromt / Cromado € 44,00  
.010 Oro / Gold / Doré / Gold / Oro € 88,00  
.560 Nero opaco / Matt black / Noir mat / Matt Schwarz / Negro mate € 62,00  
.345 Acciaio spazzolato / Brushed nickel / Acier brossé / Edelstahl Optik / Acero cepillado € 70,00  
Collezione Primavera € 102,00

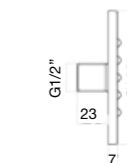

**AC1023**

Box pcs. 12

Kg 0,2



Supporto doccetta monogetto e flessibile satilux.  
Shower set composed of holder, monospray handshower and satilux flex hose.  
Garniture de douche composée de support mural, douchette mono-jet et flexible satilux.  
Brausegarnitur bestehend aus Wandhalterung, Massagehandbrause und Schlauch.

Kit de ducha con soporte, ducha masaje y flexible.

.015	Cromo / Chrome / Chromée / Verchromt / Cromado	€ 34,00
.560	Nero opaco / Matt black / Noir mat/ Matt Schwarz / Negro mate	€ 68,00
.345	Acciaio spazzolato / Brushed nickel / Acier brossé / Edelstahl Optik / Acero cepillado	€ 75,00
■ Collezione Primavera		€ 81,00

**AC1129**

Box pcs. 12

Kg 0,2



Doccia quadra.  
Square shower.  
Douche carrée.  
Mono-Wasserstrahl Handbrause.  
Ducha.

.015	Cromo / Chrome / Chromée / Verchromt / Cromado	€ 16,00
.560	Nero opaco / Matt black / Noir mat/ Matt Schwarz / Negro mate	€ 32,00
.345	Acciaio spazzolato / Brushed nickel / Acier brossé / Edelstahl Optik / Acero cepillado	€ 36,00
■ Collezione Primavera		€ 38,00

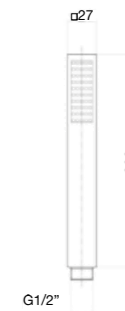
**AC0764**

Box pcs. 12

Kg 0,5



Kit supporto doccetta multifunzione e flessibile.  
Shower set composed of holder, multifunction handshower and flex hose.  
Garniture de douche composée de support mural, douchette multijet et flexible.  
Brausegarnitur bestehend aus Wandhalterung, Massagehandbrause und Schlauch.

Kit de ducha con soporte, ducha masaje y flexible.

.015	Cromo / Chrome / Chromée / Verchromt / Cromado	€ 61,00
.560	Nero opaco / Matt black / Noir mat/ Matt Schwarz / Negro mate	€ 122,00

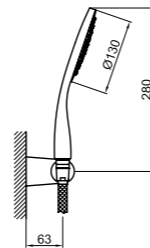
**AC0916**

Box pcs. 12

Kg 0,3



Doccetta multifunzione.  
Multifunction handshower.  
Douchette multijet.  
Massagehandbrause.  
Ducha masaje.

.015	Cromo / Chrome / Chromée / Verchromt / Cromado	€ 25,00
------	--	---------

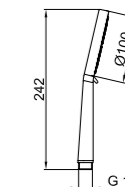
**AC0704**

Box pcs. 12

Kg 0,8



Kit supporto doccetta monogetto e flessibile.  
Shower set composed of holder, monospray handshower and flex hose.  
Garniture de douche composée de support mural, douchette monojet et flexible.  
Brausegarnitur bestehend aus Wandhalterung, 1 Funktion Handbrause und Schlauch.  
Kit de ducha con soporte, ducha y flexible.

.015	Cromo / Chrome / Chromée / Verchromt / Cromado	€ 67,00
.010	Oro / Gold / Doré / Gold / Oro	€ 135,00
.017	Cromo-Oro / Chrome-Gold / Chromé-Or / Chrom-Gold / Cromo-Oro	€ 85,00
.065	Bronzato / Bronze / Bronze / Bronze / Bronze	€ 114,00

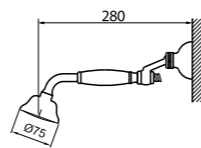
**AC0428**

Box pcs. 12

Kg 0,5



Doccetta monogetto.  
Monospray Handshower.  
Douchette mono-jet.  
Mono-Wasserstrahl Handbrause.  
Ducha.

.015	Cromo / Chrome / Chromée / Verchromt / Cromado	€ 43,00
.010	Oro / Gold / Doré / Gold / Oro	€ 55,00
.065	Bronzato / Bronze / Bronze / Bronze / Bronze	€ 55,00

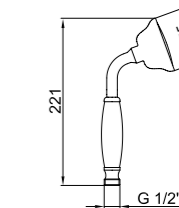
**AC0389**

Box pcs. 12

Kg 0,6



Kit supporto doccetta monogetto e flessibile.  
Shower set composed of holder, monospray handshower and flex hose.  
Garniture de douche composée de support mural, douchette mono-jet et flexible.  
Brausegarnitur bestehend aus Wandhalterung, Mono-Wasserstrahl Handbrause und Schlauch.  
Kit de ducha con soporte, ducha y flexible.

.015	Cromo / Chrome / Chromée / Verchromt / Cromado	€ 33,00
------	--	---------

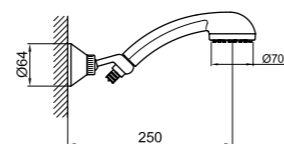
**AC0429**

Box pcs. 12

Kg 0,2



Doccetta monogetto.  
Monospray Handshower.  
Douchette mono-jet.  
Mono-Wasserstrahl Handbrause.  
Ducha.

.015	Cromo / Chrome / Chromée / Verchromt / Cromado	€ 18,00
------	--	---------

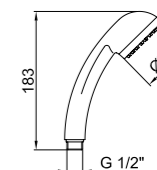

**AC0116**

Box pcs. 12

Kg 0,8



Kit supporto doccetta monogetto e flessibile.

Shower set composed of holder, monospray handshower and flex hose.

Garniture de douche composée de support mural, douchette monojet et flexible.

Brausegarnitur bestehend aus Wandhalterung, 1 Funktion Handbrause und Schlauch.

Kit de ducha con soporte, ducha y flexible.

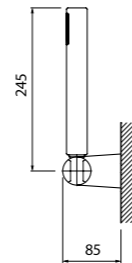

.015	Cromo / Chrome / Chromée / Verchromt / Cromado	€ 49,00
.560	Nero opaco / Matt black / Noir mat/ Matt Schwarz / Negro mate	€ 69,00

**AC0425**

Box pcs. 12

Kg 0,2



Doccetta monogetto.

Monospray Handshower.

Douchette mono-jet.

Mono-Wasserstrahl Handbrause.

Ducha.

.015	Cromo / Chrome / Chromée / Verchromt / Cromado	€ 18,00
.560	Nero opaco / Matt black / Noir mat/ Matt Schwarz / Negro mate	€ 60,00
.740	Bianco opaco / Mat white / Blanc mat / Weiss matt / Blanco mate	€ 60,00
.345	Acciaio spazzolato / Brushed nickel / Acier brossé / Edelstahl Optik / Acero cepillado	€ 69,00
.980	Oro rosa / Rose gold / Or rose / Rosegold / Oro rosa	€ 83,00
.065	Bronzato / Bronze / Bronze / Bronze / Bronze	€ 69,00
	Collezione Primavera	€ 73,00

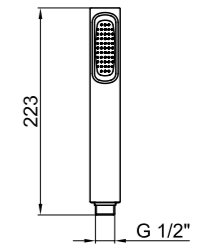
**AC0114**

Box pcs. 12

Kg 1



Kit supporto doccetta monogetto e flessibile.

Shower set composed of holder, monospray handshower and flex hose.

Garniture de douche composée de support mural, douchette monojet et flexible.

Brausegarnitur bestehend aus Wandhalterung, 1 Funktion Handbrause und Schlauch.

Kit de ducha con soporte, ducha y flexible.

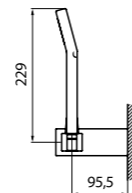

.015	Cromo / Chrome / Chromée / Verchromt / Cromado	€ 55,00
------	--	---------

**AC0426**

Box pcs. 12

Kg 0,2



Doccetta monogetto.

Monospray Handshower.

Douchette mono-jet.

Mono-Wasserstrahl Handbrause.

Ducha.

.015	Cromo / Chrome / Chromée / Verchromt / Cromado	€ 37,00
------	--	---------

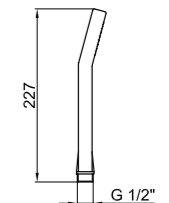
**AC0847**

Box pcs. 8

Kg 1,9



Kit supporto doccetta monogetto e flessibile con presa acqua.

Shower set composed of holder, mono spray hand shower, flex hose and wall elbow.

Garniture de douche composée de support mural, douchette monojet, flexible et coude de sortie.

Brausegarnitur bestehend aus Wandhalterung, 1 Funktion Handbrause, Schlauch und Anschlusswinkel.

Kit de ducha con soporte, ducha, tubo flexible y toma de agua.

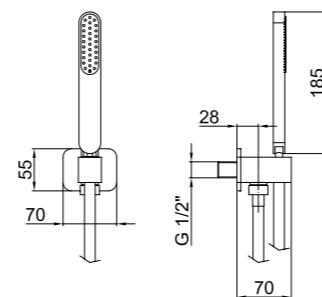

.015	Cromo / Chrome / Chromée / Verchromt / Cromado	€ 125,00
.560	Nero opaco / Matt black / Noir mat/ Matt Schwarz / Negro mate	€ 175,00

**AC0927**

Box pcs. 12

Kg 0,3



Doccetta monogetto.

Monospray Handshower.

Douchette mono-jet.

Mono-Wasserstrahl Handbrause.

Ducha.

.015	Cromo / Chrome / Chromée / Verchromt / Cromado	€ 38,00
.560	Nero opaco / Matt black / Noir mat/ Matt Schwarz / Negro mate	€ 53,00

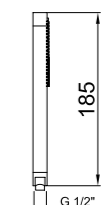

**AC0982**

Box pcs. 12

Kg 1



Kit supporto doccetta monogetto e flessibile con presa acqua.  
Shower set composed of holder, mono spray hand shower, flex hose and wall elbow.

Garniture de douche composée de support mural, douchette monojet, flexible et coude de sortie.

Brausegarnitur bestehend aus Wandhalterung, 1 Funktion Handbrause, Schlauch und Anschlusswinkel.

Kit de ducha con soporte, ducha, tubo flexible y toma de agua.

.015	Cromo / Chrome / Chromée / Verchromt / Cromado	€ 80,00
.560	Nero opaco / Matt black / Noir mat/ Matt Schwarz / Negro mate	€ 112,00
.740	Bianco opaco / Mat white / Blanc mat / Weiss matt / Blanco mate	€ 112,00
.345	Acciaio spazzolato / Brushed nickel / Acier brossé / Edelstahl Optik / Acero cepillado	€ 128,00
.980	Oro rosa / Rose gold / Or rose / Rosegold / Oro rosa	€ 155,00
.065	Bronzato / Bronze / Bronze / Bronze / Bronce	€ 128,00
	Collezione Primavera	€ 190,00

**AC1045**

Box pcs. 20

Kg 1



Kit supporto doccetta monogetto e flessibile con presa acqua.

Shower set composed of holder, mono spray hand shower, flex hose and wall elbow.

Garniture de douche composée de support mural, douchette monojet, flexible et coude de sortie.

Brausegarnitur bestehend aus Wandhalterung, 1 Funktion Handbrause, Schlauch und Anschlusswinkel.

Kit de ducha con soporte, ducha, tubo flexible y toma de agua.

.015	Cromo / Chrome / Chromée / Verchromt / Cromado	€ 60,00
.560	Nero opaco / Matt black / Noir mat/ Matt Schwarz / Negro mate	€ 118,00
.740	Bianco opaco / Mat white / Blanc mat / Weiss matt / Blanco mate	€ 118,00
.345	Acciaio spazzolato / Brushed nickel / Acier brossé / Edelstahl Optik / Acero cepillado	€ 134,00
	Collezione Primavera	€ 200,00

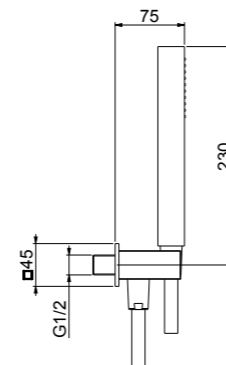
**AC1143**Kg 0,8  
Box pcs 12

Kit supporto doccetta monogetto e flessibile.

Shower set composed of holder, monospray handshower and flex hose.

Garniture de douche composée de support mural, douchette mono-jet et flexible.

Brausegarnitur bestehend aus Wandhalterung, Mono-Wasserstrahl Handbrause und Schlauch.

Kit de ducha con soporte, ducha y flexible.

.015	Cromo / Chrome / Chromée / Verchromt	€ 25,00
.560	Nero opaco / Matt black / Noir mat / Matt Schwarz	€ 50,00
	Collezione Primavera	€ 60,00

**AC0984**

Box pcs. 1

Kg 6,5



Soffione in acciaio INOX lucido fissaggio a parete.

Shiny stainless steel multifunction cascade shower head with wall shower arm.

Ciel de pluie en acier inox brillant, installation mural.

Cascade massagekopfbrause aus glänzenden edelstahl mit wandbrausearm.

Rociador de pared, inox pulido.

.845 Acciaio lucido / Shiny steel / Acier brillant / Glänzend  
Stahl / Acero brillante € 585,00

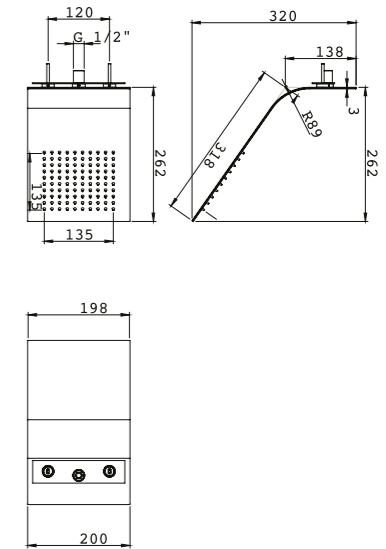
**AC0844**

Box pcs. 5

Kg 1



Soffione a soffitto anticalcare in acciaio Inox lucido con attacchi 1/2" F.

Shiny stainless steel antiscald showerhead with 1/2" connections.

Ciel de pluie au plafond anticalcaire en acier inox brillant avec attaches 1/2".

Contra Kalk Metall inox Fester-Kopfbrause mit 1/2" Anschluss.

Rociador a techo en Inox pulido, conexión 1/2" F.

.845 Acciaio lucido / Shiny steel / Acier brillant / Glänzend  
Stahl / Acero brillante € 655,00

.560 Nero opaco / Matt black / Noir mat/ Matt Schwarz / Negro mate € 760,00

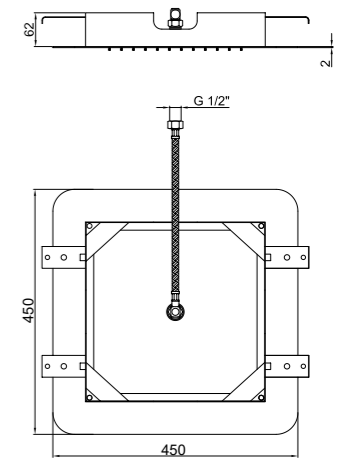

**AC0014**

Box pcs. 8

Kg 1,3



Soffione in ottone con braccio.

Brass Shower head with arm.

Pomme de douche en laiton avec bras de douche.

Metall Brausekopf mit Brausearm.

Brazo ducha de latón con rociador antical.

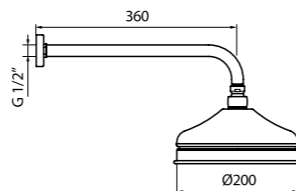

.015	Cromo / Chrome / Chromée / Verchromt / Cromado	€ 215,00
.010	Oro / Gold / Doré / Gold / Oro	€ 473,00
.017	Cromo-Oro / Chrome-Gold / Chromé-Or / Chrom-Gold / Cromo-Oro	€ 236,00
.065	Bronzato / Bronze / Bronze / Bronze / Bronze	€ 450,00

**AC0398**

Box pcs. 6

Kg 2,6



Braccio con soffione snodato.

Shower arm with ball joint and shower head.

Bras de douche avec rotule et pomme de douche.

Brausearm mit Gelenkstück und Brausekopf.

Brazo ducha con rociador con rotula.

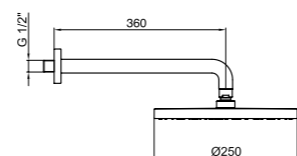

PVC	.015	Cromo / Chrome / Chromée / Verchromt / Cromado	€ 126,00	H 8 mm
STEEL	.015	Cromo / Chrome / Chromée / Verchromt / Cromado	€ 213,00	
BRASS	.560	Nero opaco / Matt black / Noir mat/ Matt Schwarz / Negro mate	€ 338,00	
BRASS	.010	Oro / Gold / Doré / Gold / Oro	€ 413,00	
STEEL		Collezione Primavera	€ 451,00	H 4 mm

**AC0013**

Box pcs. 8

Kg 1,5



Braccio con soffione snodato.

Shower arm with ball joint and shower head.

Bras de douche avec rotule et pomme de douche.

Brausearm mit Gelenkstück und Brausekopf.

Brazo ducha con rociador con rotula.

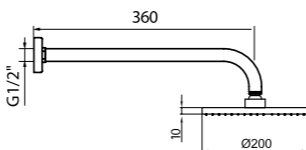

PVC	.015	Cromo / Chrome / Chromée / Verchromt / Cromado	€ 88,00	H 10 mm
STEEL	.015	Cromo / Chrome / Chromée / Verchromt / Cromado	€ 166,00	H 4 mm
BRASS	.015	Cromo / Chrome / Chromée / Verchromt / Cromado	€ 153,00	H 8 mm
BRASS	.560	Nero opaco / Matt black / Noir mat/ Matt Schwarz / Negro mate	€ 262,00	
BRASS	.345	Acciaio spazzolato / Brushed nickel / Acier brossé / Edelstahl Optik / Acero cepillado	€ 333,00	
BRASS	.980	Oro rosa / Rose gold / Or rose / Rosegold / Oro rosa	€ 351,00	
BRASS	.065	Bronzato / Bronze / Bronze / Bronze / Bronze	€ 333,00	
STEEL		Collezione Primavera	€ 340,00	H 4 mm

**AC1022**

Braccio doccia.

Shower arm.

Bras de douche.

Brause Arm.

Brazo ducha.

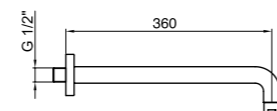

.015	Cromo / Chrome / Chromée / Verchromt / Cromado	€ 48,00
.560	Nero opaco / Matt black / Noir mat/ Matt Schwarz / Negro mate	€ 68,00
.740	Bianco opaco / Mat white / Blanc mat / Weiss matt / Bianco mate	€ 85,00
.345	Acciaio spazzolato / Brushed nickel / Acier brossé / Edelstahl Optik / Acero cepillado	€ 82,00
.980	Oro rosa / Rose gold / Or rose / Rosegold / Oro rosa	€ 116,00
.065	Bronzato / Bronze / Bronze / Bronze / Bronze	€ 85,00
	Collezione Primavera	€ 90,00

**AC1066**

Braccio a soffitto 200 mm.

Ceiling arm 200 mm.

Bras au plafond 200 mm.

Deckenanschluss 200 mm.

Brazo a techo 200 mm.

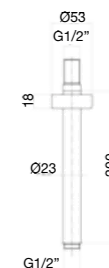

.015	Cromo / Chrome / Chromée / Verchromt / Cromado	€ 45,00
.560	Nero opaco / Matt black / Noir mat/ Matt Schwarz / Negro mate	€ 63,00
	Collezione Primavera	€ 107,00

**AC1024**

Soffione Ø200 mm.

Ø200 mm shower head.

Pomme de douche Ø200 mm.

Kopfbrause Ø200 mm.

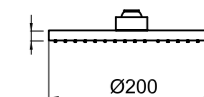

PVC	.015	Cromo / Chrome / Chromée / Verchromt / Cromado	€ 40,00	H 15 mm
STEEL	.015	Cromo / Chrome / Chromée / Verchromt / Cromado	€ 118,00	H 8 mm
BRASS	.015	Cromo / Chrome / Chromée / Verchromt / Cromado	€ 105,00	
BRASS	.560	Nero opaco / Matt black / Noir mat/ Matt Schwarz / Negro mate	€ 194,00	
BRASS	.345	Acciaio spazzolato / Brushed nickel / Acier brossé / Edelstahl Optik / Acero cepillado	€ 248,00	
BRASS	.980	Oro rosa / Rose gold / Or rose / Rosegold / Oro rosa	€ 235,00	
BRASS	.065	Bronzato / Bronze / Bronze / Bronze / Bronze	€ 248,00	
STEEL		Collezione Primavera	€ 248,00	H 4 mm

**AC1011**

Soffione Ø250 mm.

Ø250 mm shower head.

Pomme de douche Ø250 mm.

Kopfbrause Ø250 mm.

Rociador Ø250 mm.



PVC	.015	Cromo / Chrome / Chromée / Verchromt / Cromado	€ 78,00	H 15 mm
STEEL	.015	Cromo / Chrome / Chromée / Verchromt / Cromado	€ 165,00	
BRASS	.015	Cromo / Chrome / Chromée / Verchromt / Cromado	€ 147,00	H 8 mm
BRASS	.560	Nero opaco / Matt black / Noir mat/ Matt Schwarz / Negro mate	€ 270,00	
BRASS	.345	Acciaio spazzolato / Brushed nickel / Acier brossé / Edelstahl Optik / Acero cepillado	€ 350,00	
STEEL		Collezione Primavera	€ 350,00	H 4 mm

**AC1010**

Soffione Ø300 mm.

Ø300 mm shower head.

Pomme de douche Ø300 mm.

Kopfbrause Ø300 mm.

Rociador Ø300 mm.



PVC	.015	Cromo / Chrome / Chromée / Verchromt / Cromado	€ 116,00	H 15 mm
STEEL	.015	Cromo / Chrome / Chromée / Verchromt / Cromado	€ 197,00	H 8 mm
BRASS	.015	Cromo / Chrome / Chromée / Verchromt / Cromado	€ 286,00	
BRASS	.560	Nero opaco / Matt black / Noir mat/ Matt Schwarz / Negro mate	€ 348,00	
BRASS	.345	Acciaio spazzolato / Brushed nickel / Acier brossé / Edelstahl Optik / Acero cepillado	€ 533,00	
BRASS	.980	Oro rosa / Rose gold / Or rose / Rosegold / Oro rosa	€ 620,00	
BRASS	.065	Bronzato / Bronze / Bronze / Bronze / Bronze	€ 533,00	
STEEL		Collezione Primavera	€ 533,00	H 4 mm



## AC0392

Box pcs. 8

 Kg 1,5



Braccio con soffione snodato.  
Shower arm with ball joint and shower head.  
Bras de douche avec rotule et pomme de douche.  
Brausearm mit Gelenkstück und Brausekopf.  
Brazo ducha con rociador con rotula.

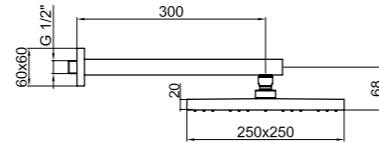

PVC .015	Cromo / Chrome / Chromée / Verchromt / Cromado	€ 200,00	H 8 mm
STEEL .015	Cromo / Chrome / Chromée / Verchromt / Cromado	€ 316,00	H 8 mm
BRASS .560	Nero opaco / Matt black / Noir mat/ Matt Schwarz / Negro mate	€ 390,00	H 4 mm
	Collezione Primavera	€ 499,00	

## AC0843

Box pcs. 8

 Kg 1,5



Soffione con braccio.  
Shower head with arm.  
Pomme de douche avec bras de douche.  
Kopfbrause mit Brausearm.  
Brazo ducha con rociador.

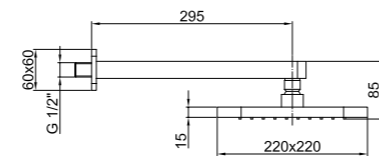

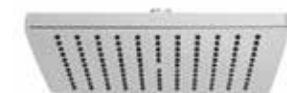

PVC .015	Cromo / Chrome / Chromée / Verchromt / Cromado	€ 215,00	
BRASS .015	Cromo / Chrome / Chromée / Verchromt / Cromado	€ 330,00	
BRASS .560	Nero opaco / Matt black / Noir mat/ Matt Schwarz / Negro mate	€ 460,00	
BRASS .345	Acciaio spazzolato / Brushed nickel / Acier brossé / Edelstahl Optik / Acero cepillado	€ 520,00	

## AC1012

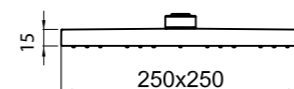

Soffione 250x250 mm.  
250x250 mm shower head.  
Pomme de douche 250x250 mm.  
Kopfbrause 250x250 mm.  
Rociador 250x250 mm.



PVC .015	Cromo / Chrome / Chromée / Verchromt / Cromado	€ 112,00	H 15 mm
BRASS .015	Cromo / Chrome / Chromée / Verchromt / Cromado	€ 230,00	H 8 mm
STEEL .015	Cromo / Chrome / Chromée / Verchromt / Cromado	€ 220,00	
BRASS .560	Nero opaco / Matt black / Noir mat/ Matt Schwarz / Negro mate	€ 268,00	
BRASS .345	Acciaio spazzolato / Brushed nickel / Acier brossé / Edelstahl Optik / Acero cepillado	€ 390,00	
STEEL 	Collezione Primavera	€ 390,00	H 4 mm

## AC1013



Soffione 300x300 mm.  
300x300 mm shower head.  
Pomme de douche 300x300 mm.  
Kopfbrause 300x300 mm.  
Rociador 300x300 mm.





BRASS .015	Cromo / Chrome / Chromée / Verchromt / Cromado	€ 245,00	H 8 mm
STEEL .015	Cromo / Chrome / Chromée / Verchromt / Cromado	€ 235,00	H 4 mm
BRASS .560	Nero opaco / Matt black / Noir mat/ Matt Schwarz / Negro mate	€ 382,00	
BRASS .345	Acciaio spazzolato / Brushed nickel / Acier brossé / Edelstahl Optik / Acero cepillado	€ 416,00	
STEEL 	Collezione Primavera	€ 416,00	H 4 mm

## AC1025

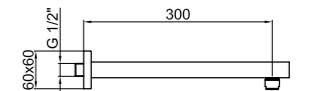

Braccio doccia.  
Shower arm.  
Bras de douche.  
Brause Arm.  
Brazo ducha.





.015	Cromo / Chrome / Chromée / Verchromt / Cromado	€ 96,00	
.560	Nero opaco / Matt black / Noir mat/ Matt Schwarz / Negro mate	€ 122,00	
.345	Acciaio spazzolato / Brushed nickel / Acier brossé / Edelstahl Optik / Acero cepillado	€ 155,00	
	Collezione Primavera	€ 155,00	

## AC1080

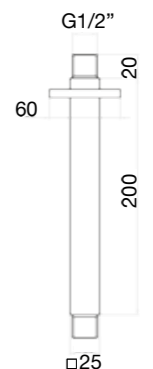

Braccio a soffitto.  
Ceiling arm.  
Bras au plafond.  
Deckenanschluss.  
Brazo a techo.



.015	Cromo / Chrome / Chromée / Verchromt / Cromado	€ 42,00	
.560	Nero opaco / Matt black / Noir mat/ Matt Schwarz / Negro mate	€ 59,00	
	Collezione Primavera	€ 102,00	

**AC0929**

Box pcs. 6

Kg 1,4



Saliscendi doccia, con doccetta multifunzione.  
 Sliding rail with multifunction handshower.  
 Barre de douche avec douchette multijet.  
 Brausegarnitur mit Wandstange und Massagehandbrause.  
 Conjunto de barra de ducha deslizante con ducha masaje.

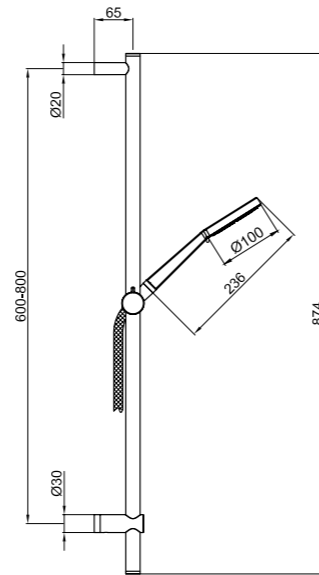

.015 Cromo / Chrome / Chromée / Verchromt / Cromado € 135,00  
 .560 Nero opaco / Matt black / Noir mat / Matt Schwarz / Negro mate € 216,00

**AC1154**

Saliscendi con doccetta monogetto.  
 Sliding rail, with monospray handshower.  
 Barre de douche avec douchette monojet.  
 Wandstange mit Mono-Wasserstrahl Handbrause.  
 Barra de ducha deslizante y ducha.

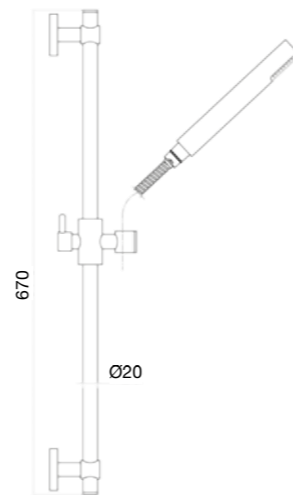

Collezione Primavera € 280,00

**AC1155**

Saliscendi con doccetta monogetto.  
 Sliding rail, with monospray handshower.  
 Barre de douche avec douchette monojet.  
 Wandstange mit Mono-Wasserstrahl Handbrause.  
 Barra de ducha deslizante y ducha.

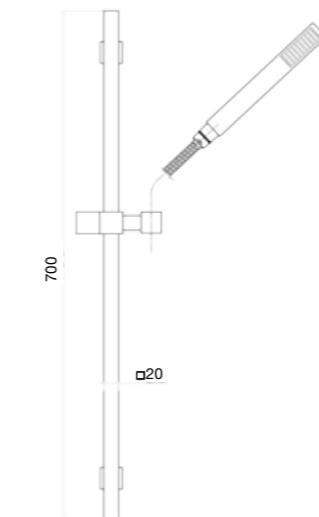

.015 Cromo / Chrome / Chromée / Verchromt / Cromado € 145,00  
 .560 Nero opaco / Matt black / Noir mat / Matt Schwarz / Negro mate € 220,00  
 Collezione Primavera € 290,00

**AC0384**

Box pcs. 6

Kg 2,1



Saliscendi in ottone, con doccetta monogetto.  
 Brass sliding rail, with monospray handshower.  
 Barre de douche en laiton, avec douchette monojet.  
 Messing Wandstange, mit Mono-Wasserstrahl Handbrause.  
 Conjunto de barra de ducha deslizante y ducha.

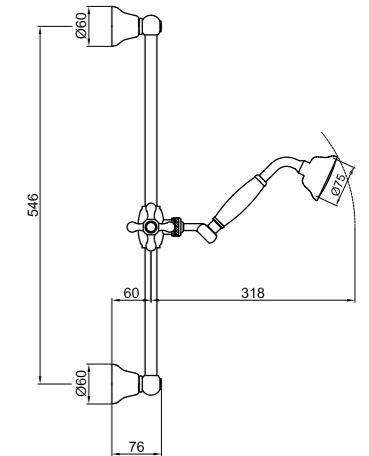

.015 Cromo / Chrome / Chromée / Verchromt / Cromado € 195,00  
 .010 Oro / Gold / Doré / Gold / Oro € 295,00  
 .017 Cromo-Oro / Chrome-Gold / Chromé-Or / Chrom-Gold / Cromo-Oro € 240,00  
 .065 Bronzato / Bronze / Bronze / Bronze / Bronze € 295,00

**AC0479**

Box pcs. 6

Kg 0,8

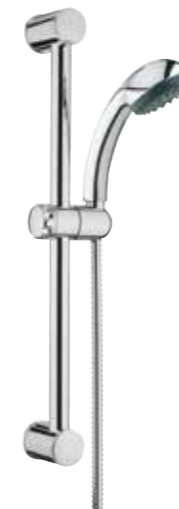

Saliscendi in ottone, con doccetta monogetto.  
 Brass sliding rail, with monospray handshower.  
 Barre de douche en laiton, avec douchette monojet.  
 Messing Wandstange, mit Mono-Wasserstrahl Handbrause.  
 Conjunto de barra de ducha deslizante y ducha.

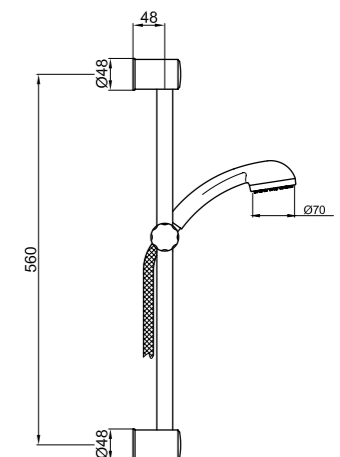

.015 Cromo / Chrome / Chromée / Verchromt / Cromado € 78,00

## AC1221



Bocca d'erogazione senza deviatore per vasca incasso.  
 Spout for concealed bath mixer.  
 Bec pour mitigeur bain/douche encastré.  
 Gussauslauf für Unterputz-Badebatterie.  
 Boca de erogación sin desviador para bañera empotrable.

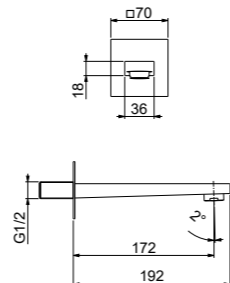

.015 Cromo / Chrome / Chromée / Verchromt / Cromado € 93,00

## AC1220



Bocca d'erogazione con deviatore per vasca incasso.  
 Spout for concealed bath mixer.  
 Bec pour mitigeur bain/douche encastré.  
 Gussauslauf für Unterputz-Badebatterie.  
 Boca de erogación sin desviador para bañera empotrable.

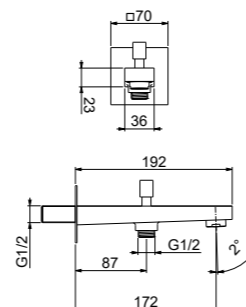

.015 Cromo / Chrome / Chromée / Verchromt / Cromado € 110,00

## AC1223



Bocca d'erogazione senza deviatore per vasca incasso.  
 Spout for concealed bath mixer.  
 Bec pour mitigeur bain/douche encastré.  
 Gussauslauf für Unterputz-Badebatterie.  
 Boca de erogación sin desviador para bañera empotrable.

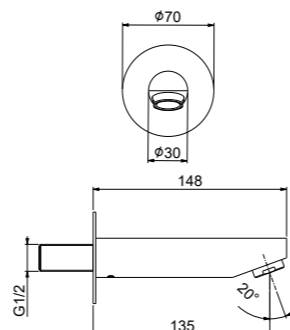

.015 Cromo / Chrome / Chromée / Verchromt / Cromado € 75,00

## AC1222



Bocca d'erogazione con deviatore per vasca incasso.  
 Spout for concealed bath mixer.  
 Bec pour mitigeur bain/douche encastré.  
 Gussauslauf für Unterputz-Badebatterie.  
 Boca de erogación sin desviador para bañera empotrable.

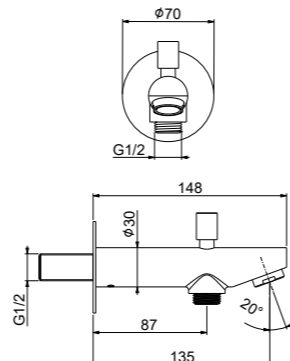

.015 Cromo / Chrome / Chromée / Verchromt / Cromado € 92,00

## AC0983



Bocca d'erogazione senza deviatore per vasca incasso.  
 Spout for concealed bath mixer.  
 Bec pour mitigeur bain/douche encastré.  
 Gussauslauf für Unterputz-Badebatterie.  
 Boca de erogación sin desviador para bañera empotrable.

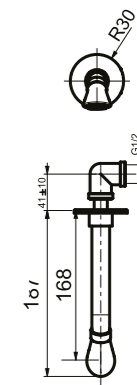

.015 Cromo / Chrome / Chromée / Verchromt / Cromado € 114,00  
 .010 Oro / Gold / Doré / Gold / Oro € 228,00  
 .980 Oro rosa / Rose gold / Or rose / Rosegold / Oro rosa € 285,00

AC0470000 AC0979015

## AC0402



Bocca d'erogazione senza deviatore per vasca incasso;  
 attacco da 3/4".  
 Spout for concealed bath mixer, 3/4" connection.  
 Bec pour mitigeur bain/douche encastré, attache 3/4".  
 Gussauslauf für Unterputz-Badebatterie, 3/4" Anschluss.  
 Boca de erogación sin desviador para bañera empotrable;  
 conexión 3/4".

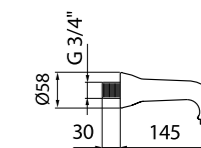

.015 Cromo / Chrome / Chromée / Verchromt / Cromado € 92,00  
 .017 Cromo-Oro / Chrome-Gold / Chromé-Or / Chrom-Gold / Cromo-Oro € 98,00  
 .065 Bronzato / Bronze / Bronze / Bronze / Bronze € 133,00

## AC0944



Bocca d'erogazione senza deviatore per vasca incasso.  
 Spout for concealed bath mixer.  
 Bec pour mitigeur bain/douche encastré.  
 Gussauslauf für Unterputz-Badebatterie.  
 Boca de erogación sin desviador para bañera empotrable.

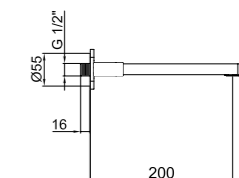

.015 Cromo / Chrome / Chromée / Verchromt / Cromado € 170,00

## AC0371



Bocca d'erogazione senza deviatore per vasca incasso;  
 attacco da 1/2".  
 Spout for concealed bath mixer, 1/2" connection.  
 Bec pour mitigeur bain/douche encastré, attache 1/2".  
 Gussauslauf für Unterputz-Badebatterie, 1/2" Anschluss.  
 Boca de erogación sin desviador para bañera empotrable;  
 conexión 1/2".

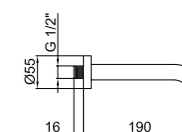

.015 Cromo / Chrome / Chromée / Verchromt / Cromado € 78,00  
 .560 Nero opaco / Matt black / Noir mat / Matt Schwarz / Negro mate € 109,00  
 .345 Acciaio spazzolato / Brushed nickel / Acier brossé / Edelstahl Optik / Acero cepillado € 125,00

**AC0869**

Bocca d'erogazione senza deviatore per vasca incasso; attacco da 1/2"

Spout for concealed bath mixer, 1/2" connection.

Bec pour mitigeur bain/douche encastré, attache 1/2".

Gussauslauf für Unterputz-Badebatterie, 1/2" Anschluss.

Boca de erogación sin desviador para bañera empotrable; conexión 1/2".

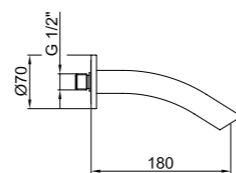

.015 Cromo / Chrome / Chromée / Verchromt / Cromado € 165,00

.560 Nero opaco / Matt black / Noir mat/ Matt Schwarz / Negro mate € 173,00

.844 Bianco Lucido-Cromo / Shiny White-Chrome / Blanc Brillant-Chromé / Glänzend Weiss-Chrom / Blanco Brillante-Cromado € 173,00

**AC0945**

Bocca d'erogazione senza deviatore per vasca incasso.

Spout for concealed bath mixer.

Bec pour mitigeur bain/douche encastré.

Gussauslauf für Unterputz-Badebatterie.

Boca de erogación sin desviador para bañera empotrable

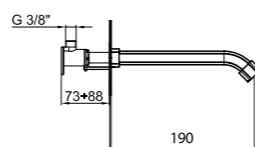

.015 Cromo / Chrome / Chromée / Verchromt / Cromado € 140,00

**AC0407**

KIT prolunga doccia incasso Ø 40.

Extension for concealed shower mixer Ø 40.

Rallonge pour mitigeur de douche encastré cartouche Ø 40.

Verlängerung zu Unterputz-Brausebatterie Ø 40.

Prolongación para mezclador monomando empotrado ducha Ø 40.



.015 Cromo / Chrome / Chromée / Verchromt / Cromado € 42,00

**AC0408**

KIT prolunga doccia incasso Ø 35.

Extension for concealed shower mixer Ø 35.

Rallonge pour mitigeur de douche encastré cartouche Ø 35.

Verlängerung zu Unterputz-Brausebatterie Ø 35 .

Prolongación para mezclador monomando empotrado ducha Ø 35.



.015 Cromo / Chrome / Chromée / Verchromt / Cromado € 40,00

**AC0938**

KIT prolunga doccia incasso Ø 35 ARIA-LOTHO-YPSOLON.

Extension for concealed shower mixer Ø 35 ARIA-LOTHO-YPSILON.

Rallonge pour mitigeur de douche encastré cartouche Ø 35 ARIA-LOTHO-YPSILON.

Verlängerung zu Unterputz-Brausebatterie Ø 35 ARIA-LOTHO-YPSILON.

Prolongación para mezclador monomando empotrado ducha Ø 35 ARIA-LOTHO-YPSILON.



.015 Cromo / Chrome / Chromée / Verchromt / Cromado € 44,00

**AC0409**

Prolunga completa per rubinetto incasso. (no karenina)



.000 Neutro / Neutral / Neutre / Neutral / Neutral € 30,00

**PE870605**

Set idroscopino con doccia quadra.

Hydrobrush set with square hand shower.

Kit douchette Shut-Off avec douchette carrée.

Hydrobürste Set mit eckiger Handbrause

Mezclador de pared con ducha higiénica PVC.



.015 Cromo / Chrome / Chromée / Verchromt / Cromado € 216,00

.560 Nero opaco / Matt black / Noir mat/ Matt Schwarz / Negro mate € 302,00

.345 Acciaio spazzolato / Brushed nickel / Acier brossé / Edelstahl Optik / Acero cepillado € 346,00

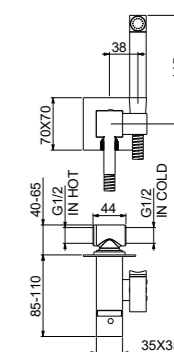
**EL870304**

Set idroscopino con doccia tonda.

Hydrobrush set with round hand shower

Kit douchette Shut-Off avec douchette stylo.

Hydrobürste Set mit runder Handbrause

Mezclador de pared con ducha higiénica PVC.



.015 Cromo / Chrome / Chromée / Verchromt / Cromado € 160,00

.560 Nero opaco / Matt black / Noir mat/ Matt Schwarz / Negro mate € 224,00

.345 Acciaio spazzolato / Brushed nickel / Acier brossé / Edelstahl Optik / Acero cepillado € 256,00

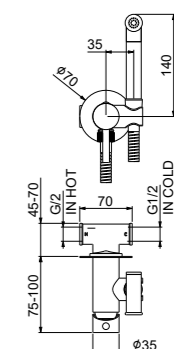

# KITCHEN



LONDON  
LO920301  
Miscelatore lavello.  
One hole sink mixer.

LO940301  
Miscelatore lavello con doccetta estraibile.  
One hole sink mixer with pull-out shower.



TOULOUSE  
TO940301  
Miscelatore lavello con doccetta estraibile.  
One hole sink mixer with pull-out shower.

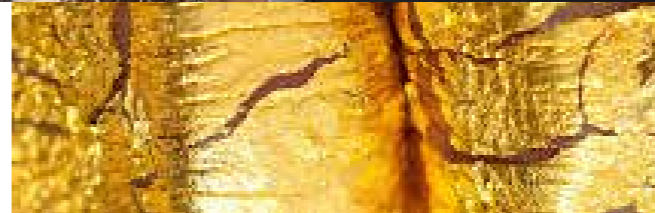
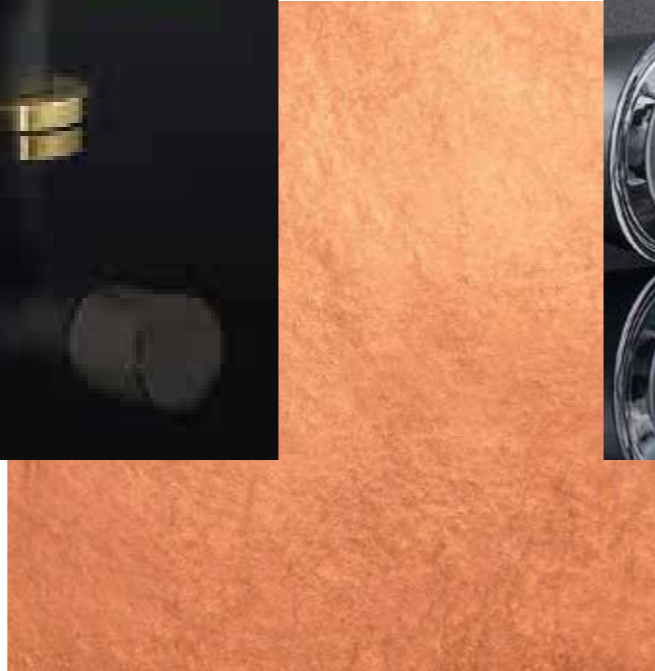

### SO920301.722

Box pcs. 6

Kg 3



Miscelatore monocomando per lavello SPIRIT, canna orientabile, flessibili cm 70 3/8" F.

Single lever sink mixer SPIRIT, swivel spout, with 3/8" F flex. hoses cm 70.

Mitigeur dévier SPIRIT avec bec mobile et flexible d'alimentation cm 70 3/8" F.

EHM Stand-Spültischbatterie SPIRIT, mit schwenkbarem Auslauf und flex. Anschlussschläuchen cm 70 3/8" F.

Monomando para fregadero SPIRIT, caño orientable y tubos flexibles de 70 cm, 3/8" F.

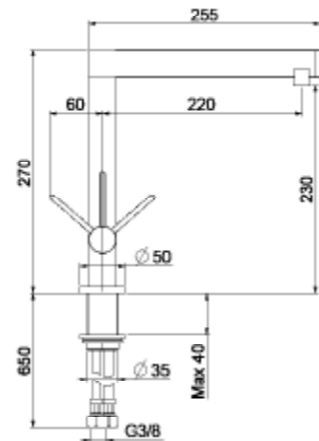

.722 Nero opaco+rame PVD / Matt black+copper PVD / Noir mat+cuivre PVD / Matt Schwarz+ KupferPVD / Negro mate+ Cobre PVD € 320,00

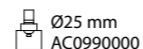

SO920302

### SO920301.723

Box pcs. 6

Kg 3



Miscelatore monocomando per lavello SPIRIT, canna orientabile, flessibili cm 70 3/8" F.

Single lever sink mixer SPIRIT, swivel spout, with 3/8" F flex. hoses cm 70.

Mitigeur dévier SPIRIT avec bec mobile et flexible d'alimentation cm 70 3/8" F.

EHM Stand-Spültischbatterie SPIRIT, mit schwenkbarem Auslauf und flex. Anschlussschläuchen cm 70 3/8" F.

Monomando para fregadero SPIRIT, caño orientable y tubos flexibles de 70 cm, 3/8" F.

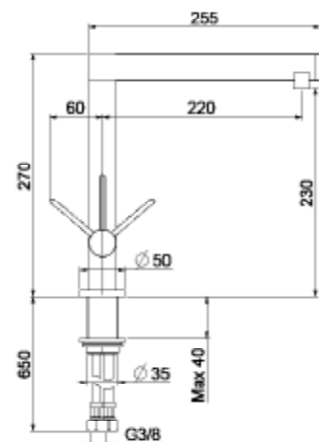

.723 Nero opaco+oro PVD / Matt black+gold PVD / Noir mat+or PVD / Matt Schwarz+Gold PVD / Negro mate+oro PVD € 320,00

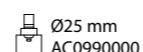

### SO920301.724

Box pcs. 6

Kg 3



Miscelatore monocomando per lavello SPIRIT, canna orientabile, flessibili cm 70 3/8" F.

Single lever sink mixer SPIRIT, swivel spout, with 3/8" F flex. hoses cm 70.

Mitigeur dévier SPIRIT avec bec mobile et flexible d'alimentation cm 70 3/8" F.

EHM Stand-Spültischbatterie SPIRIT, mit schwenkbarem Auslauf und flex. Anschlussschläuchen cm 70 3/8" F.

Monomando para fregadero SPIRIT, caño orientable y tubos flexibles de 70 cm, 3/8" F.

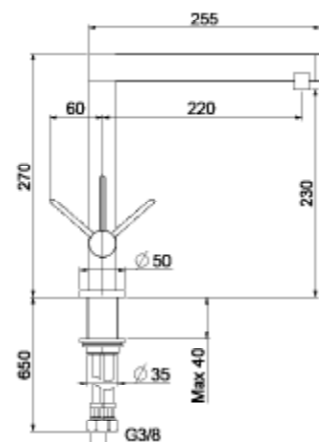

.724 Nero opaco+antracite PVD / Matt black+antracite PVD / Noir mat+antracite PVD / Matt Schwarz+Anthrakit PVD / Negro mate+antracita PVD € 320,00

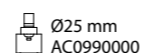

### YN920301.722

Box pcs. 8

Kg 1,9



Miscelatore monocomando per lavello YEN, canna orientabile, flessibili cm 50 3/8" F.

Single lever sink mixer YEN, swivel spout, with 3/8" F flex. hoses cm 50.

Mitigeur dévier YEN avec bec mobile et flexible d'alimentation cm 50 3/8" F.

EHM Stand-Spültischbatterie YEN, mit schwenkbarem Auslauf und flex. Anschlussschläuchen cm 50 3/8" F.

Monomando para fregadero YEN, caño orientable y tubos flexibles de 50 cm, 3/8" F.

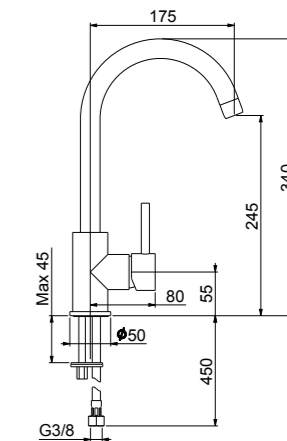

YN920302

.722 Nero opaco+rame PVD / Matt black+copper PVD / Noir mat+cuivre PVD / Matt schwarz+ KupferPVD / Negro mate+ Cobre PVD € 178,00



### YN920301.723

Box pcs. 8

Kg 1,9



Miscelatore monocomando per lavello YEN, canna orientabile, flessibili cm 50 3/8" F.

Single lever sink mixer YEN, swivel spout, with 3/8" F flex. hoses cm 50.

Mitigeur dévier YEN avec bec mobile et flexible d'alimentation cm 50 3/8" F.

EHM Stand-Spültischbatterie YEN, mit schwenkbarem Auslauf und flex. Anschlussschläuchen cm 50 3/8" F.

Monomando para fregadero YEN, caño orientable y tubos flexibles de 50 cm, 3/8" F.

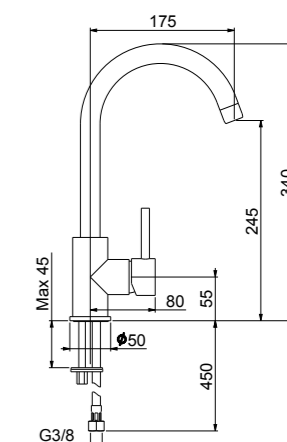

YN920302

.723 Nero opaco+oro PVD / Matt black+gold PVD / Noir mat+or PVD / Matt Schwarz+Gold PVD / Negro mate+oro PVD € 178,00

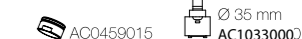

### YN920301.724

Box pcs. 8

Kg 1,9



Miscelatore monocomando per lavello YEN, canna orientabile, flessibili cm 50 3/8" F.

Single lever sink mixer YEN, swivel spout, with 3/8" F flex. hoses cm 50.

Mitigeur dévier YEN avec bec mobile et flexible d'alimentation cm 50 3/8" F.

EHM Stand-Spültischbatterie YEN, mit schwenkbarem Auslauf und flex. Anschlussschläuchen cm 50 3/8" F.

Monomando para fregadero YEN, caño orientable y tubos flexibles de 50 cm, 3/8" F.

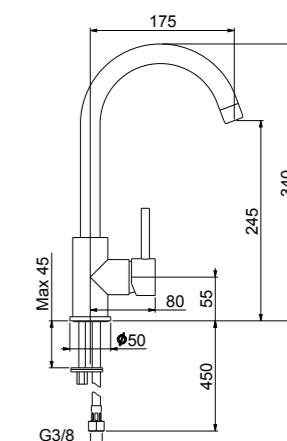

YN920302

.724 Nero opaco+antracite PVD / Matt black+antracite PVD / Noir mat+antracite PVD / Matt Schwarz+Anthrakit PVD / Negro mate+antracita PVD € 178,00



## ON921201

Box pcs. 4

 Kg 1,6



Miscelatore monocomando per lavello ONE-A, canna orientabile, flessibili cm 70 3/8" F.

Single lever sink mixer ONE-A, swivel spout, with 3/8" F flex. hoses cm 70.

Mitigeur évier ONE-A avec bec mobile et flexible d'alimentation cm 70 3/8" F.

EHM Stand-Spültischbatterie ONE-A, mit schwenkbarem Auslauf und flex. Anschlussschläuchen cm 70 3/8" F.

Monomando para fregadero ONE-A, caño orientable y tubos flexibles de 70 cm, 3/8" F.

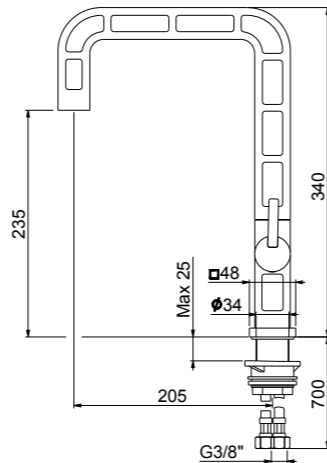

 ON921202

.441 Acciaio + nero / Steel + black / Acier + noir / Stahl + Schwarz / Acero + negro € 2.350,00

.560 Nero opaco / Matt black / Noir mat / Matt Schwarz / Negro mate € 2.350,00



## EN920301

Box pcs. 4

 Kg 1,7



Miscelatore monocomando per lavello ESSENTIAL, canna orientabile, flessibili cm 70 3/8" F.

Single lever sink mixer ESSENTIAL, swivel spout, with 3/8" F flex. hoses cm 70.

Mitigeur évier ESSENTIAL avec bec mobile et flexible d'alimentation cm 70 3/8" F.

EHM Stand-Spültischbatterie ESSENTIAL, mit schwenkbarem Auslauf und flex. Anschlussschläuchen cm 70 3/8" F.

Monomando para fregadero ESSENTIAL, caño orientable y tubos flexibles de 70 cm, 3/8" F.

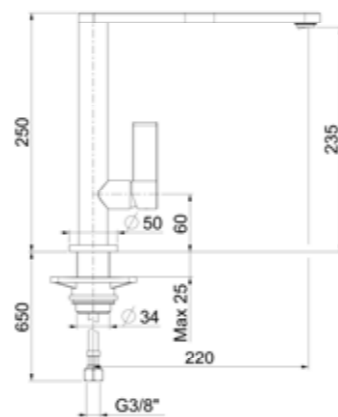

 EN921202

.441 Acciaio + nero / Steel + black / Acier + noir / Stahl + Schwarz / Acero + negro € 740,00

.560 Nero opaco / Matt black / Noir mat / Matt Schwarz / Negro mate € 740,00



## OB920601

Box pcs. 4

 Kg 1,6



Design: Manuela Busetti e Matteo Redaelli

 OB920602

Miscelatore monocomando per lavello OBLIQUE PRO, con doccetta estraibile e canna orientabile a 360° e flessibili cm 37 3/8" F.

OBLIQUE PRO single lever sink mixer with pull-out spray, with 3/8" F flex. hoses cm 37, swivel spout.

Mitigeur d'évier série OBLIQUE PRO avec bec mobile, douche extractible et flexibles d'alimentation cm 37 3/8" F.

EHM Stand-Spültischbatterie, Armaturensérie OBLIQUE PRO, mit Geschirrbrause, schwenkbarem Auslauf und flex. Anschlussschläuchen cm 37 3/8" F.

Mezclador monomando para fregadero OBLIQUE PRO con ducha extraible, caño orientable 360° y tubos flexibles de 37 cm, 3/8" F.

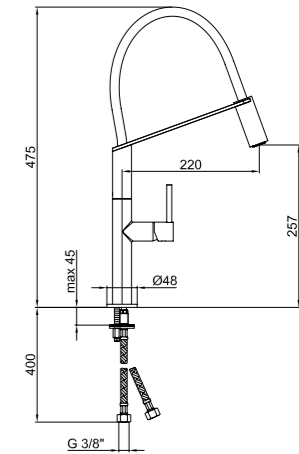

.015 Cromo / Chrome / Chromée / Verchromt / Cromado € 295,00



## TO940301

Box pcs. 4

 Kg 1,6



 TO940302

Miscelatore monocomando per lavello TOULOUSE, con doccetta monogetto estraibile e canna orientabile a 360° e flessibili cm 50 3/8" F.

TOULOUSE single lever sink mixer with pull-out 1 jet spray, with 3/8" F flex. hoses cm 50, swivel spout.

Mitigeur d'évier série TOULOUSE avec bec mobile, douche extractible 1 jet et flexibles d'alimentation cm 50 3/8" F.

EHM Stand-Spültischbatterie, Armaturensérie TOULOUSE, mit Einstrahl-Handbrause, schwenkbarem Auslauf und flex. Anschlussschläuchen cm 50 3/8" F.

Mezclador monomando para fregadero TOULOUSE con ducha extraible un chorro, caño orientable 360° y tubos flexibles de 50 cm, 3/8" F.

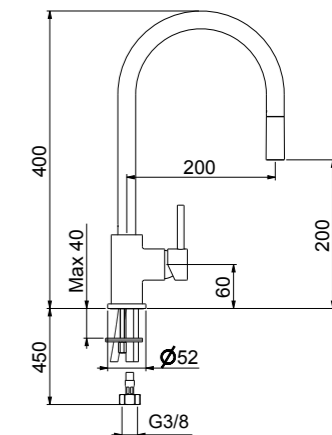

.015 Cromo / Chrome / Chromée / Verchromt / Cromado € 148,00

.564 Nero opaco-Cromo / Matt black-Chrome / Noir mat-Chromé / Matt Schwarz-Verchromt / Negro mate-Cromado € 162,00

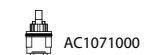

## VT940301

Box pcs. 4

 Kg 1,6



 VT940302

Miscelatore monocomando per lavello VOLTERRA, con doccetta estraibile 2 getti e canna orientabile a 360° e flessibili cm 50 3/8" F.

VOLTERRA single lever sink mixer with pull-out 2 jets spray, with 3/8" F flex. hoses cm 50, swivel spout.

Mitigeur d'évier série VOLTERRA avec bec mobile, douche extractible 2 jets et flexibles d'alimentation cm 50 3/8" F.

EHM Stand-Spültischbatterie, Armaturensérie VOLTERRA, mit Zweistrahl-Handbrause, schwenkbarem Auslauf und flex. Anschlussschläuchen cm 50 3/8" F.

Mezclador monomando para fregadero VOLTERRA con ducha extraible dos chorros, caño orientable 360° y tubos flexibles de 50 cm, 3/8" F.

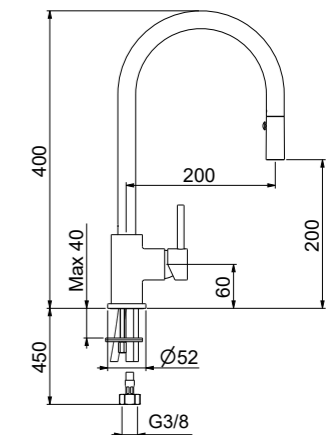

.015 Cromo / Chrome / Chromée / Verchromt / Cromado € 165,00

.564 Nero opaco-Cromo / Matt black-Chrome / Noir mat-Chromé / Matt Schwarz-Verchromt / Negro mate-Cromado € 180,00

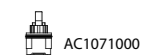

## DK940301

Box pcs. 4

 Kg 1,6



Miscelatore monocomando per lavello DAKAR, con doccetta estraibile e canna orientabile a 360° e flessibili cm 50 3/8" F.

DAKAR single lever sink mixer with pull-out spray, with 3/8" F flex. hoses cm 50, swivel spout.

Mitigeur d'évier série DAKAR avec bec mobile, douchette extractible et flexibles d'alimentation cm 50 3/8" F.

EHM Stand-Spültischbatterie, Armaturensérie DAKAR, mit Geschirrbrause, schwenkbarem Auslauf und flex. Anschlussschläuchen cm 50 3/8" F.

Mezclador monomando para fregadero DAKAR con ducha extraíble, caño orientable 360° y tubos flexibles de 50 cm, 3/8" F.

.015 Cromo / Chrome / Chromée / Verchromt / Cromado € 197,00

.560 Nero opaco / Matt black / Noir mat / Matt Schwarz / Negro mate € 276,00

 DK940302



## KE920301

Box pcs. 6

 Kg 2,9



Miscelatore monocomando per lavello KEO, canna orientabile a 180° e flessibili cm 37 3/8" F.

Single lever sink mixer swivel spout KEO, with 3/8" F flex. hoses cm 37.

Mitigeur d'évier série KEO avec bec mobile et flexibles d'alimentation cm 37 3/8" F.

EHM Stand-Spültischbatterie KEO, mit schwenkbarem Auslauf und Anschlussschläuchen cm 37 3/8" F.

Mezclador monomando para fregadero KEO, caño orientable 180° y tubos flexibles de 37 cm, 3/8" F.

.015 Cromo / Chrome / Chromée / Verchromt / Cromado € 252,00

 KE920302

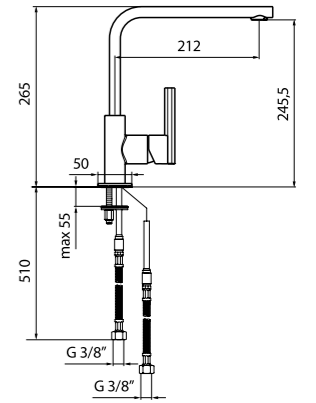

## LV920301

Box pcs. 8

 Kg 1,9



Miscelatore monocomando per lavello LIVING, canna orientabile a 180° e flessibili cm 37 3/8" F.

Single lever sink mixer LIVING swivel spout, with 3/8" F flex. hoses cm 37.

Mitigeur d'évier série LIVING avec bec mobile et flexibles d'alimentation cm 37 3/8" F.

EHM Stand-Spültischbatterie LIVING, mit schwenkbarem Auslauf und Anschlussschläuchen cm 37 3/8" F.

Mezclador monomando para fregadero LIVING, caño orientable 180° y tubos flexibles de 37 cm, 3/8" F.

.015 Cromo / Chrome / Chromée / Verchromt / Cromado € 240,00

 LV920302

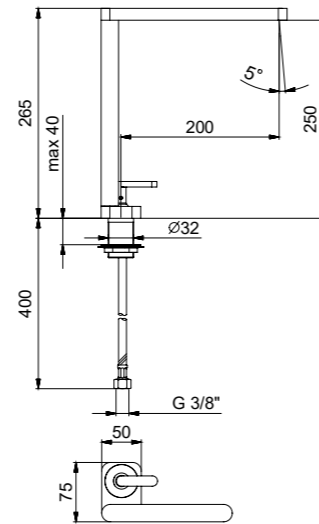

## HB940301

Box pcs. 6

 Kg 3



Miscelatore monocomando per lavello doccetta estraibile HABITAT con canna orientabile a 360° e flessibili cm 37 3/8" F.

HABITAT single lever sink mixer with pull-out spray, swivel spout, 3/8" F flex. hoses cm 37.

Mitigeur d'évier à mousseur extractible série HABITAT, bec mobile et flexibles d'alimentation cm 37 3/8" F.

EHM Stand-Spültischbatterie Armaturensérie HABITAT m/ Zugauslauf, schwenkbarem Auslauf, flex. Anschlussschläuchen cm. 37 3/8" F.

Mezclador monomando para fregadero HABITAT, ducha extraíble, con caño orientable 360° y tubos flexibles de 37 cm, 3/8" F.

.015 Cromo / Chrome / Chromée / Verchromt / Cromado € 263,00

 HB940302

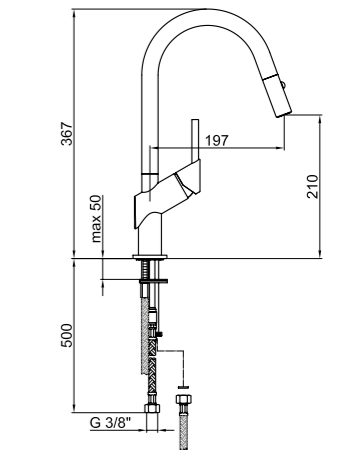

## SO920301

Box pcs. 6

 Kg 3



Miscelatore monocomando per lavello SPIRIT, canna orientabile a 180° e flessibili cm 37 3/8" F.

Single lever sink mixer SPIRIT swivel spout, with 3/8" F flex. hoses cm 37.

Mitigeur d'évier série SPIRIT avec bec mobile et flexibles d'alimentation cm 37 3/8" F.

EHM Stand-Spültischbatterie SPIRIT, mit schwenkbarem Auslauf und Anschlussschläuchen cm 37 3/8" F.

Mezclador monomando para fregadero SPIRIT, caño orientable 180° y tubos flexibles de 37 cm, 3/8" F.

.015 Cromo / Chrome / Chromée / Verchromt / Cromado € 215,00

.564 Nero opaco-Cromo / Matt black-Chrome / Noir mat-Chromé / Matt Schwarz-Verchromt / Negro mate-Cromado € 230,00

 SO920302

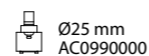
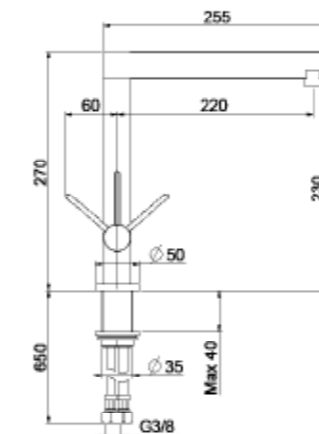

## OM920601

Box pcs. 4

 Kg 3,6



Miscelatore monocomando per lavello professionale OMEGA con doccetta estraibile e flessibili cm 37 3/8" F H 45 cm.

OMEGA professional single lever sink mixer with pull-out spray, swivel spout, 3/8" F flex. hoses cm 37 H 45 cm.

Mitigeur d'évier professionnel série OMEGA avec douchette et flexibles d'alimentation cm 37 3/8" F H 45 cm.

Professionelle EHM Stand-Spültischbatterie, Armaturensérie OMEGA, mit Zugauslauf und flex. Anschlussschläuchen cm 37 3/8" F H 45 cm.

Monomando para fregadero profesional OMEGA, con extraíble y tubos flexibles de 37 cm, 3/8" F. H 45 cm.

.015 Cromo / Chrome / Chromée / Verchromt / Cromado € 370,00

Design: Massimiliano Settimelli

 OM920602

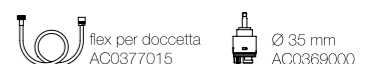
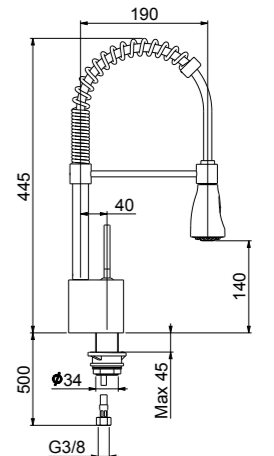

## CN920601

Box pcs. 6

 Kg 3,2



Miscelatore monocomando per lavello professionale CONIC con doccetta estraibile e flessibili cm 50 3/8" F H 47 cm.

CONIC professional single lever sink mixer with pull-out-spray, swivel spout, 3/8" F flex. hoses cm 50 H 47 cm.

Mitigeur d'évier professionnel série CONIC avec douchette et flexibles d'alimentation cm 50 3/8" F H 47 cm.

Professionelle EHM Stand-Spültischbatterie, Armaturensérie CONIC, mit Zugauslauf und flex. Anschlussschläuchen cm 50 3/8" F H 47 cm.

Monomando para fregadero profesional CONIC, con ducha extraíble y tubos flexibles de 50 cm, 3/8" F. H 47 cm.

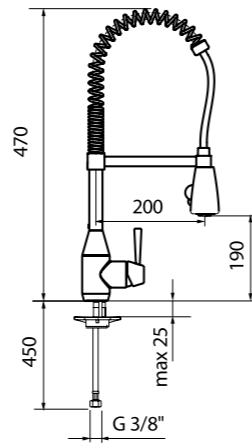

 CN920602

.015 Cromo / Chrome / Chromée / Verchromt / Cromado € 324,00



## SN921401

Box pcs. 4

 Kg 7



Miscelatore monocomando per lavello professionale SPRINGY con doccetta estraibile e flessibili cm 50 3/8" F. H 68 cm.

SPRINGY professional single lever sink mixer with pull-out-spray, swivel spout, 3/8" F flex. hoses cm 50 H 68 cm.

Mitigeur d'évier professionnel série SPRINGY avec douchette et flexibles d'alimentation cm 50 3/8" F. H 68 cm.

Professionelle EHM Stand-Spültischbatterie, Armaturensérie SPRINGY, mit Zugauslauf und flex. Anschlussschläuchen cm. 50 3/8" F. H 68 cm.

Monomando para fregadero profesional SPRINGY, con ducha extraíble y tubos flexibles de 50 cm, 3/8" F. H 68 cm.

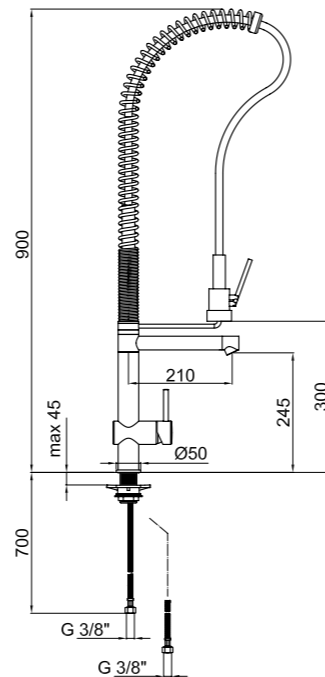

 SN921402

.015 Cromo / Chrome / Chromée / Verchromt / Cromado € 625,00



## IB920801

Box pcs. 12

 Kg 2,3



Monoforo lavello miscelatore con deviatore per acqua potabile IBIZA.

IBIZA single lever sink mixer with drinking water diverter.

Mitigeur d'évier IBIZA avec inverseur pour eau potable.

Einhebelmischer Stand-Spültischbatterie IBIZA mit Umstellung für Trinkwasser.

Monoblock para fregadero IBIZA, mezclador con desviador para agua potable.

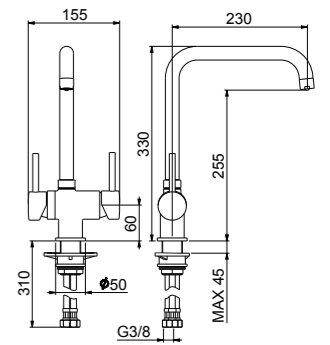

 IB920802

.015 Cromo / Chrome / Chromée / Verchromt / Cromado € 260,00

.560 Nero opaco / Matt black / Noir mat / Matt Schwarz / Negro mate € 312,00

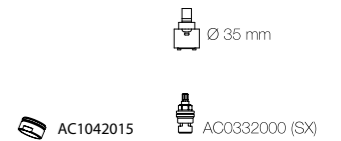

## BY920801

Box pcs. 12

 Kg 2,3



Monoforo lavello miscelatore con deviatore per acqua potabile BYBLOS.

BYBLOS single lever sink mixer with drinking water diverter.

Mitigeur d'évier BYBLOS avec inverseur pour eau potable.

Einhebelmischer Stand-Spültischbatterie BYBLOS mit Umstellung für Trinkwasser.

Monoblock para fregadero BYBLOS, mezclador con desviador para agua potable.

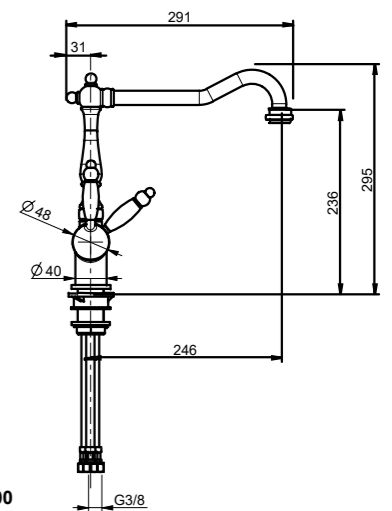

 BY920802

.015 Cromo / Chrome / Chromée / Verchromt / Cromado € 270,00

.010 Oro / Gold / Doré / Gold / Oro € 396,00

.065 Bronzato / Bronze / Bronze / Bronze / Bronze € 360,00



## SY940301

Box pcs. 6

 Kg 3,5



Miscelatore monocomando per lavello SIDNEY, con doccetta estraibile 2 getti e canna orientabile a 360° e flessibili cm 50 3/8" F.

SIDNEY single lever sink mixer with pull-out spray 2 jets, with 3/8" F flex. hoses cm 50, swivel spout.

Mitigeur d'évier série SIDNEY avec bec mobile, douchette extractible 2 jets et flexibles d'alimentation cm 50 3/8" F.

EHM Stand-Spültischbatterie, Armaturensérie SIDNEY, mit Zweistrah-Handbrause, schwenkbarem Auslauf und flex. Anschlussschläuchen cm 50 3/8" F.

Mezclador monomando para fregadero SIDNEY con ducha extraíble dos chorros, caño orientable 360° y tubos flexibles de 50 cm, 3/8" F.

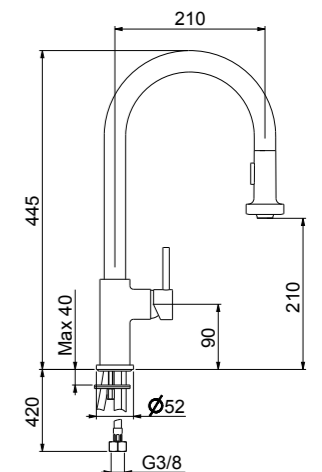

 SY940302

.015 Cromo / Chrome / Chromée / Verchromt / Cromado € 160,00

.564 Nero opaco-Cromo / Matt black-Chrome / Noir mat-Chromé / Schwarz Matt-Chrom / Negro mate-Cromado € 210,00

.345 Acciaio / Brushed nickel / Acier brossé / Edelstahl Optik / Acero cepillado € 230,00

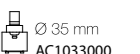

## DH940301

Box pcs. 6

 Kg 3,2



 DH940302

Miscelatore monocomando per lavello DOHA, con doccetta estraibile 2 getti e canna orientabile a 360° e flessibili cm 50 3/8" F.

DOHA single lever sink mixer with pull-out spray 2 jets, with 3/8" F flex. hoses cm 50, swivel spout.

Mitigeur d'évier série DOHA avec bec mobile, douchette extractible 2 jets et flexibles d'alimentation cm 50 3/8" F.

EHM Stand-Spültischbatterie, Armaturensérie DOHA, mit Zweistrahln-Handbrause, schwenkbarem Auslauf und flex. Anschlusschläuchen cm 50 3/8" F.

Mezclador monomando para fregadero DOHA con ducha extraíble dos chorros, caño orientable 360° y tubos flexibles de 50 cm, 3/8" F.

.015 Cromo / Chrome / Chromée / Verchromt / Cromado € 163,00

.560 Nero opaco / Matt black / Noir mat / Schwarz Matt / Negro mate € 190,00

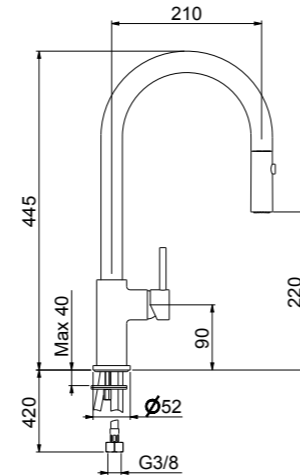

 Ø 35 mm  
AC1033000

## BA920301

Box pcs. 8

 Kg 1,9



 BA920302

Miscelatore monocomando per lavello BALTIMORA, canna orientabile e flessibili cm 50 3/8" F.

BALTIMORA single lever sink mixer swivel spout, with 3/8" F flex. hoses cm 50.

Mitigeur d'évier série BALTIMORA avec bec mobile et flexibles d'alimentation cm 50 3/8" F.

EHM Stand-Spültischbatterie BALTIMORA, mit schwenkbarem Auslauf und Anschlusschläuchen cm 50 3/8" F.

Mezclador monomando para fregadero BALTIMORA, caño orientable 180° y tubos flexibles de 50 cm, 3/8" F.

.015 Cromo / Chrome / Chromée / Verchromt / Cromado € 125,00

.560 Nero opaco / Matt black / Noir mat / Schwarz Matt / Negro mate € 148,00

.345 Acciaio / Brushed nickel / Acier brossé / Edelstahl Optik / Acero cepillado € 163,00

Collezione Primavera € 230,00

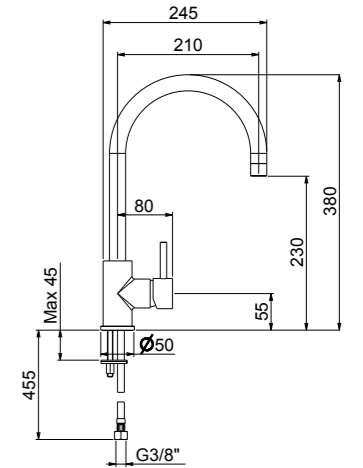

 AC1053015  Ø35 mm  
AC1033000

## OB920301

Box pcs. 6

 Kg 1,8



 OB920302

Miscelatore monocomando per lavello OBLIQUE, canna orientabile e flessibili cm 50 3/8" F.

OBLIQUE single lever sink mixer swivel spout, with 3/8" F flex. hoses cm 50.

Mitigeur d'évier série OBLIQUE avec bec mobile et flexibles d'alimentation cm 50 3/8" F.

EHM Stand-Spültischbatterie OBLIQUE, mit schwenkbarem Auslauf und Anschlusschläuchen cm 50 3/8" F.

Mezclador monomando para fregadero OBLIQUE, caño orientable 180° y tubos flexibles de 50 cm, 3/8" F.

.015 Cromo / Chrome / Chromée / Verchromt / Cromado € 125,00

.560 Nero opaco / Matt black / Noir mat / Schwarz Matt / Negro mate € 148,00

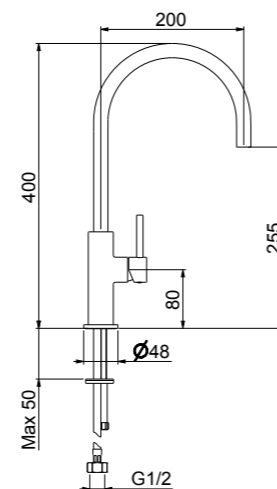

 AC0469015  Ø25 mm  
AC1072000

## WD920701

Box pcs. 8

 Kg 2,3



 WD920702

Miscelatore monocomando per lavello sottofinestra WINDOW, canna orientabile a 360° e flessibili cm 37 3/8" F.

Single lever sink mixer under-window WINDOW, swivel spout, with 3/8" F flex. hoses cm 37.

Mitigeur d'évier sous-fenêtre WINDOW avec bec mobile et flexibles d'alimentation cm 37 3/8" F.

EHM Stand-Spültischbatterie Unter-Fenster WINDOW, mit schwenkbarem Auslauf und flex. Anschlusschläuchen cm. 37 3/8" F.

Monomando para fregadero ubicado debajo de una ventana WINDOW, caño orientable 360° y tubos flexibles de 37 cm, 3/8" F.

.015 Cromo / Chrome / Chromée / Verchromt / Cromado € 222,00

.560 Nero opaco / Matt black / Noir mat / Matt Schwarz / Negro mate € 266,00

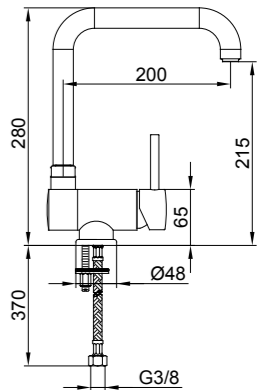

 AC0461015  Ø40 mm  
AC0370000

## LM940301

Box pcs. 6

 Kg 2,6



 LM940302

Miscelatore monocomando per lavello LIMA, con doccetta estraibile e canna orientabile a 360° e flessibili cm 50 3/8" F.

LIMA single lever sink mixer with pull-out spray, with 3/8" F flex. hoses cm 50, swivel spout.

Mitigeur d'évier série LIMA avec bec mobile, douchette extractible et flexibles d'alimentation cm 50 3/8" F.

EHM Stand-Spültischbatterie, Armaturensérie LIMA, mit Geschirrbrause, schwenkbarem Auslauf und flex. Anschlusschläuchen cm 50 3/8" F.

Mezclador monomando para fregadero LIMA con ducha extraíble, caño orientable 360° y tubos flexibles de 50 cm, 3/8" F.

.015 Cromo / Chrome / Chromée / Verchromt / Cromado € 165,00

.560 Nero opaco / Matt black / Noir mat / Schwarz Matt / Negro mate € 198,00

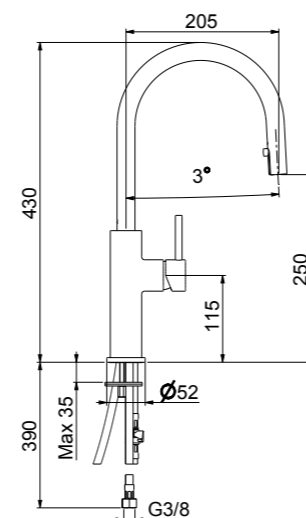

 Ø 35 mm  
AC1033000

## YN920301

Box pcs. 8

 Kg 1,9



 YN920302

Miscelatore monocomando per lavello YEN, canna orientabile a 360° e flessibili cm 50 3/8" F.

Single lever sink mixer swivel spout YEN, with 3/8" F flex. hoses cm 50.

Mitigeur d'évier série avec bec mobile et flexibles YEN d'alimentation cm 50 3/8" F.

EHM Stand-Spültischbatterie, Armaturensérie YEN, mit schwenkbarem Auslauf und flex Anschlusschläuchen cm 50 3/8" F.

Monomando para fregadero YEN, caño orientable 360° y tubos flexibles de 50 cm, 3/8" F.

.015 Cromo / Chrome / Chromée / Verchromt / Cromado € 119,00

.560 Nero opaco / Matt black / Noir mat / Schwarz Matt / Negro mate € 140,00

.740 Bianco opaco / Matt white / Blanc mat / Weiss Matt / Blanco mate € 140,00

.345 Acciaio / Brushed nickel / Acier brossé / Edelstahl Optik / Acero cepillado € 155,00

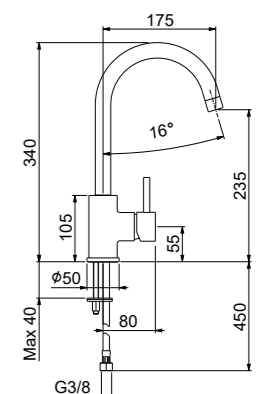

 AC0459015  Ø35 mm  
AC1033000

## PR920301

Box pcs. 8

 Kg 1,9



Miscelatore monocomando per lavello PRAGA, canna orientabile a 360° e flessibili cm 50 3/8" F.

Single lever sink mixer swivel spout PRAGA, with 3/8" F flex. hoses cm 50.

Mitigeur d'évier série avec bec mobile et flexibles PRAGA d'alimentation cm 50 3/8" F.



EHM Stand-Spültischbatterie, Armaturensérie PRAGA, mit schwenkbarem Auslauf und flex Anschlusschläuchen cm 50 3/8" F.

Monomando para fregadero PRAGA, caño orientable 360° y tubos flexibles de 50 cm, 3/8" F.

.015 Cromo / Chrome / Chromée / Verchromt / Cromado € 145,00

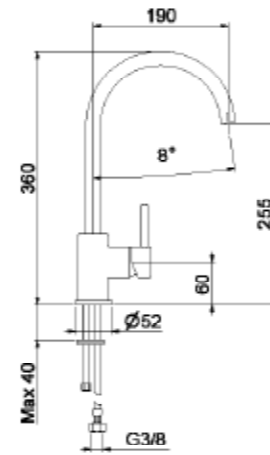
.560 Nero opaco / Matt black / Noir mat / Schwarz Matt / Negro mate € 171,00



 AC0469015  Ø35 mm AC1033000

 PR920302

## VP920601

Box pcs. 8

 Kg 1,5



Miscelatore monocomando per lavello VIPER, canna orientabile a 360° e flessibili cm 50 3/8" F.

Single lever sink mixer swivel spout VIPER, with 3/8" F flex. hoses cm 50.

Mitigeur d'évier série avec bec mobile et flexibles VIPER d'alimentation cm 50 3/8" F.

EHM Stand-Spültischbatterie, Armaturensérie VIPER, mit schwenkbarem Auslauf und flex Anschlusschläuchen cm 50 3/8" F.

Monomando para fregadero VIPER, caño orientable 360° y tubos flexibles de 50 cm, 3/8" F.

.564 Nero opaco-Cromo / Matt black-Chrome / Noir mat-Chromé / Schwarz Matt-Chrom / Negro mate-Cromado € 156,00

.744 Bianco opaco-Cromo / Matt white-Chrome / Blanc mat-Chromé / Glanzend Matt-Chrom / Blanco mate-Cromado € 156,00

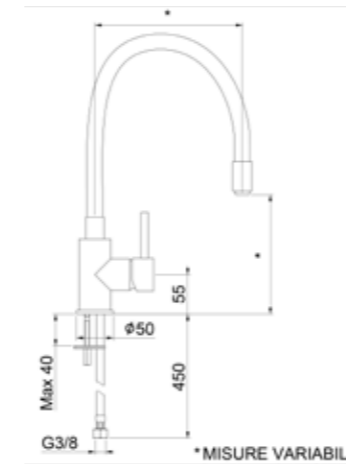

 Ø35 mm AC1033000

 VP920602

## LO920301

Box pcs. 8

 Kg 2,3



Miscelatore monocomando per lavello LONDON, canna orientabile a 360° e flessibili cm 50 3/8" F.

LONDON single lever sink mixer swivel spout, with 3/8" F flex. hoses cm 50.

Mitigeur d'évier série LONDON avec bec mobile et flexibles d'alimentation cm 50 3/8" F.

EHM Stand-Spültischbatterie, Armaturensérie LONDON, mit schwenkbarem Auslauf und flex. Anschlusschläuchen cm 50 3/8" F.

Mezclador monomando para fregadero LONDON, caño orientable 360° y tubos flexibles de 50 cm, 3/8" F.



.015 Cromo / Chrome / Chromée / Verchromt / Cromado € 127,00

.560 Nero opaco / Matt black / Noir mat / Schwarz Matt / Negro mate € 149,00

.740 Bianco opaco / Matt white / Blanc mat / Weiss Matt / Blanco mate € 149,00

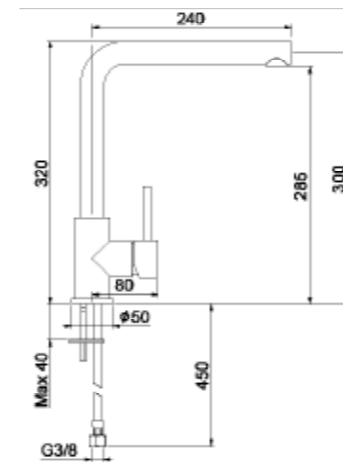
.345 Acciaio / Brushed nickel / Acier brossé / Edelstahl Optik / Acero cepillado € 165,00



 AC1071015  Ø35 mm AC1033000

 VP920602

## LO940301

Box pcs. 8

 Kg 2,6



Miscelatore monocomando per lavello LONDON con doccetta estraibile, bocca orientabile a 360° e flessibili cm 50 3/8" F.

LONDON single lever sink mixer with pull-out spray, with 3/8" F flex. hoses cm 50, swivel spout.

Mitigeur d'évier série LONDON avec bec mobile, douchette extractible et flexibles d'alimentation cm 50 3/8" F.

EHM Stand-Spültischbatterie, Armaturensérie LONDON, mit Geschirrbrause, schwenkbarem Auslauf und flex. Anschlusschläuchen cm 50 3/8" F.

Mezclador monomando para fregadero LONDON con ducha extraíble, caño orientable 360° y tubos flexibles de 50 cm, 3/8" F.

.015 Cromo / Chrome / Chromée / Verchromt / Cromado € 142,00

.560 Nero opaco / Matt black / Noir mat / Schwarz Matt / Negro mate € 167,00

.740 Bianco opaco / Matt white / Blanc mat / Weiss Matt / Blanco mate € 167,00

.345 Acciaio / Brushed nickel / Acier brossé / Edelstahl Optik / Acero cepillado € 185,00

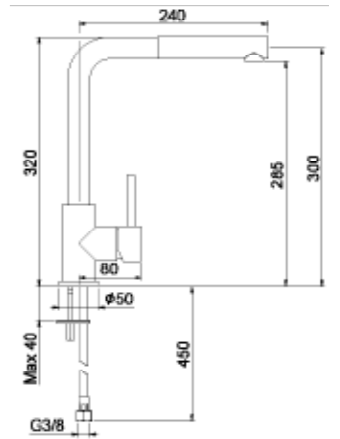

 Ø35 mm AC1033000

 LO940302

## SX940101

Box pcs. 12

 Kg 2,4



Miscelatore monocomando per lavello con doccetta estraibile SAX, bocca orientabile a 360° e flessibili cm 37 3/8" F.

SAX single lever sink mixer with pull-out spray, swivel spout with 3/8" F flex. hoses cm 37.

Mitigeur d'évier série SAX avec bec mobile, douchette extractible double jet et flexibles d'alimentation cm 37 3/8" F.

EHM Stand-Spültischbatterie, Armaturensérie SAX, mit Zugauslauf, schwenkbarem Auslauf und flex. Anschlusschläuchen cm 37 3/8" F.

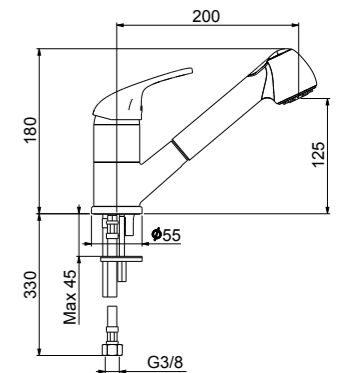

Monomando para fregadero con rociador extraíble SAX, caño orientable a 360° y tubos flexibles de 37 cm, 3/8" F.



 flex per doccetta AC0386015

 SX940102

.015 Cromo / Chrome / Chromée / Verchromt / Cromado € 135,00

 AC0462015  Ø40 mm AC0370000

## SX920101

Box pcs. 12

 Kg 1,8



Miscelatore monocomando per lavello, canna orientabile a 360° e flessibili cm 37 3/8" F.

Single lever sink mixer, swivel spout, with 3/8" F flex. hoses cm 37.

Mitigeur d'évier avec bec mobile et flexibles d'alimentation cm 37 3/8" F.

EHM Stand-Spültischbatterie, mit schwenkbarem Auslauf und flex. Anschlusschläuchen cm 37 3/8" F.

Monomando para fregadero, caño orientable 360° y tubos flexibles de 37 cm, 3/8" F.

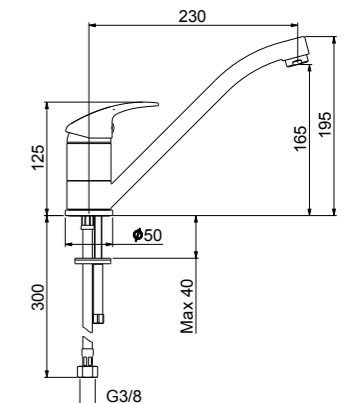

.015 Cromo / Chrome / Chromée / Verchromt / Cromado € 85,00

 AC0462015  Ø40 mm AC0370000

 SX920102

## SX920201

Box pcs. 12

 Kg 1,8



Miscelatore monocomando per lavello inclinato, bocca idroformata orientabile a 360° e flessibili cm 37 3/8" F.

Single lever sink mixer, goose neck and forged swivel spout, with 3/8" F flex. hoses cm 37.

Mitigeur d'évier série avec bec mobile idroformé et flexibles d'alimentation cm 37 3/8" F.

EHM Stand-Spültischbatterie, Armaturensérie, mit schwenkbarem Auslauf und flex. Anschlussschläuchen cm. 37 3/8" F.

Monomando para fregadero inclinado, caño hidroformado orientable 360° y tubos flexibles de 37 cm, 3/8" F.

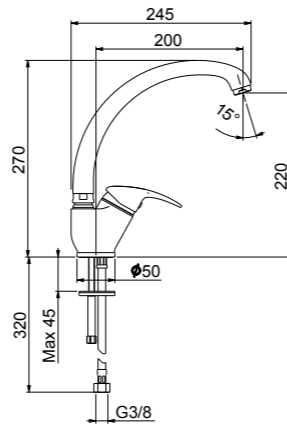

 SX920202

.015 Cromo / Chrome / Chromée / Verchromt / Cromado € 95,00

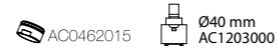

## SP920101

Box pcs. 12

 Kg 1,7



Miscelatore monocomando per lavello leva clinica SEMPLICE, canna orientabile a 360° e flessibili cm 37 3/8" F.

SEMPLICE single lever sink mixer sanitary lever, swivel spout, with 3/8" F flex. hoses cm 37.

Mitigeur d'évier série SEMPLICE avec bec mobile, poignée clinique et flexibles d'alimentation cm 37 3/8" F.

EHM Stand-Spültischbatterie, Armaturensérie SEMPLICE, Klinik Hebel, mit schwenkbarem Auslauf und flex. Anschlussschläuchen cm. 37 3/8" F.

Mezclador monomando para fregadero SEMPLICE, manilla tipo clínica, caño orientable 360° y tubos flexibles de 37 cm, 3/8" F.

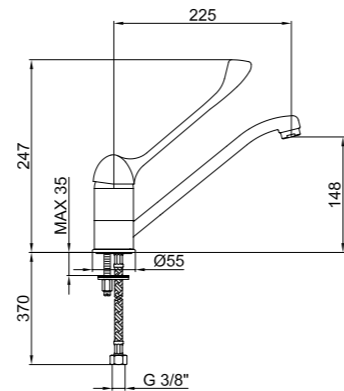

 SP920102

.015 Cromo / Chrome / Chromée / Verchromt / Cromado € 110,00



## SX910101

Box pcs. 12

 Kg 1,7



Miscelatore monocomando lavello a parete, bocca orientabile idroformata cm 20.

Wall mounted single lever sink mixer with forged swivel spout.

Mitigeur mural d'évier série avec bec idroformé mobile.

EHM Wand-Spültischbatterie, mit schwenkbarem Auslauf.

Monomando fregadero de pared, caño hidroformado orientable de 20 cm.

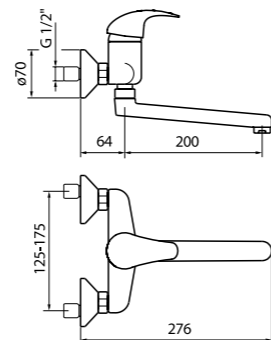

.015 Cromo / Chrome / Chromée / Verchromt / Cromado € 120,00

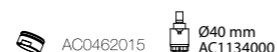

## DO780101

Box pcs. 8

 Kg 2,1



Monoforo due maniglie per lavello DORIAN, con canna orientabile stile antico a 360° e flessibili cm 37 3/8" F.

DORIAN sink mixer with old fashion swivel spout, 3/8" F flex. hoses cm 37.

Mélangeur d'évier rétro DORIAN avec bec mobile et flexibles d'alimentation cm 37 3/8" F.

Stand-Spültisch-Einlochbatterie DORIAN mit schwenkbarem waagerechtem Auslauf und flex. Anschlussschläuchen cm. 37 3/8" F.

Monoblock de dos manillas para fregadero DORIAN, con caño orientable 360°, estilo antiguo, tubos flexibles de 37 cm, 3/8" F.

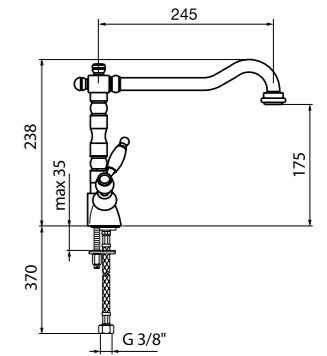

 DO780102

.015 Cromo / Chrome / Chromée / Verchromt / Cromado € 205,00

.010 Oro / Gold / Doré / Gold / Oro € 245,00

.065 Bronzato / Bronze / Bronze / Bronze / Bronze € 262,00



## VA920301

Box pcs. 8

 Kg 2,2



Miscelatore monocomando per lavello VALENTINO, canna orientabile a 360° e flessibili cm 50 3/8" F.

VALENTINO single lever sink mixer, swivel spout, with 3/8" F flex hoses cm 50.

Mitigeur d'évier VALENTINO avec bec mobile et flexibles d'alimentation cm 50 3/8" F.

EHM Stand-Spültischbatterie VALENTINO, mit schwenkbarem Auslauf und flex. Anschlussschläuchen cm. 50 3/8" F.

Monomando para fregadero VALENTINO, caño orientable 360° y tubos flexibles de 50 cm, 3/8" F.

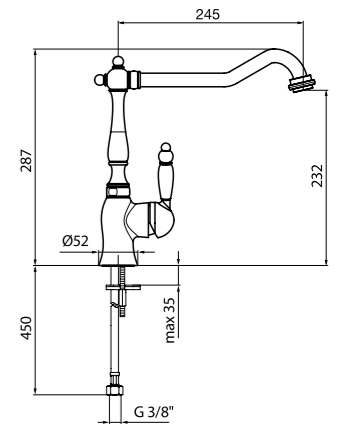

 VA920302

.015 Cromo / Chrome / Chromée / Verchromt / Cromado € 302,00

.010 Oro / Gold / Doré / Gold / Oro € 380,00

.065 Bronzato / Bronze / Bronze / Bronze / Bronze € 355,00



## AM780101

Box pcs. 8

 Kg 2,2



Monoforo due maniglie per lavello ARMONY, con canna orientabile stile antico a 360° e flessibili cm 37 3/8" F.

ARMONY double control sink mixer with old fashion swivel spout, 3/8" F flex. hoses cm 37.

Mélangeur d'évier rétro série ARMONY avec bec mobile et flexibles d'alimentation cm 37 3/8" F.

Stand-Spültisch-Einlochbatterie, Armaturensérie ARMONY, schwenkbarem waagerechtem Auslauf und flex. Anschlussschläuchen cm. 37 3/8" F.

Monoblock de dos manillas para fregadero ARMONY, con caño orientable 360°, estilo antiguo, tubos flexibles de 37 cm, 3/8" F.

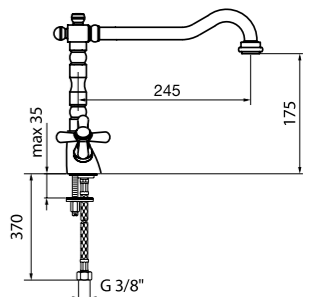

 AM780102

.015 Cromo / Chrome / Chromée / Verchromt / Cromado € 141,00

.065 Bronzato / Bronze / Bronze / Bronze / Bronze € 176,00



### AM780301

Box pcs. 8

Kg 2,4



Monoforo due maniglie per lavello ARMONY, con bocca idroformata orientabile a 360° e flessibili cm 37 3/8" F.

ARMONY double control sink mixer, forged swivel spout with 3/8" F flex. hoses cm 37.

Mélangeur d'évier série ARMONY avec bec coulé mobile hydroformé et flexibles d'alimentation cm 37 3/8" F.

Stand-Spültisch-Einlochbatterie, Armaturensérie ARMONY, mit schwenkbarem Auslauf und flex. Anschlussschläuchen cm 37 3/8" F.

Monoblock dos manillas para fregadero ARMONY con caño hidroformado orientable 360° y tubos flexibles cm 37 3/8" F.

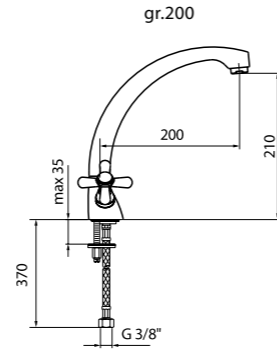

.015 Cromo / Chrome / Chromée / Verchromt / Cromado € 105,00

.065 Bronzato / Bronze / Bronze / Bronze / Bronze € 142,00



AM780302

### AM770101

Box pcs. 12

Kg 1,2



Lavello a parete ARMONY, con canna orientabile cm 20.

ARMONY wall mounted double control sink mixer with swivel spout 20 cm.

Mélangeur mural d'évier série ARMONY avec bec mobile de 20 cm.

Wand-Spültischbatterie, Armaturensérie ARMONY, mit schwenkbarem Auslauf, 20 cm.

Fregadero de pared ARMONY, con caño orientable de 20 cm.

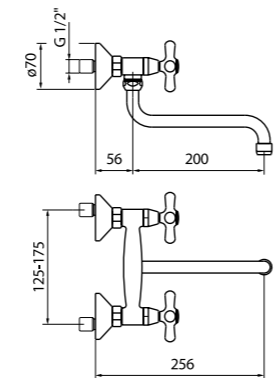

.015 Cromo / Chrome / Chromée / Verchromt / Cromado € 86,00

.065 Bronzato / Bronze / Bronze / Bronze / Bronze € 130,00

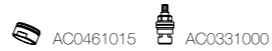

### MT780101

Box pcs. 12

Kg 1,2



Monoforo due maniglie per lavello MALTA con canna orientabile a 360° e flessibili cm 37 3/8" F.

MALTA double control sink mixer, swivel spout with 3/8" F flex. hoses cm 37.

Mélangeur d'évier série MALTA avec bec mobile et flexibles d'alimentation cm 37 3/8" F.

Stand-Spültisch-Einlochbatterie Armaturensérie MALTA, mit schwenkbarem Auslauf und flex. Anschlussschläuchen cm 37 3/8" F.

Monoblock dos manillas para fregadero MALTA con caño orientable 360° y tubos flexibles cm 37 3/8" F.

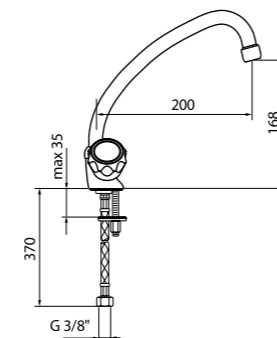

.015 Cromo / Chrome / Chromée / Verchromt / Cromado € 66,00



MT780102

### MT770101

Box pcs. 12

Kg 1,1



Lavello a parete MALTA, con canna orientabile cm 20.

MALTA wall mounted double control sink mixer with swivel spout 20 cm.

Mélangeur mural d'évier série MALTA avec bec mobile de 20 cm.

Wand-Spültischbatterie, Armaturensérie MALTA, mit schwenkbarem Auslauf 20 cm.

Fregadero de pared MALTA, con caño orientable de 20 cm.

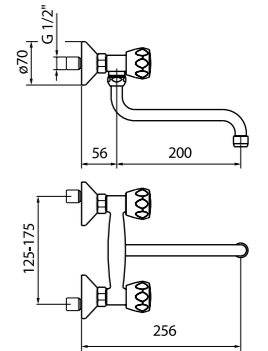

.015 Cromo / Chrome / Chromée / Verchromt / Cromado € 65,00



LIMA  
LM940301

Miscelatore lavello con doccia estraibile.  
One hole sink mixer with pull-out shower.

# ACCESSORIES & SPARE PARTS

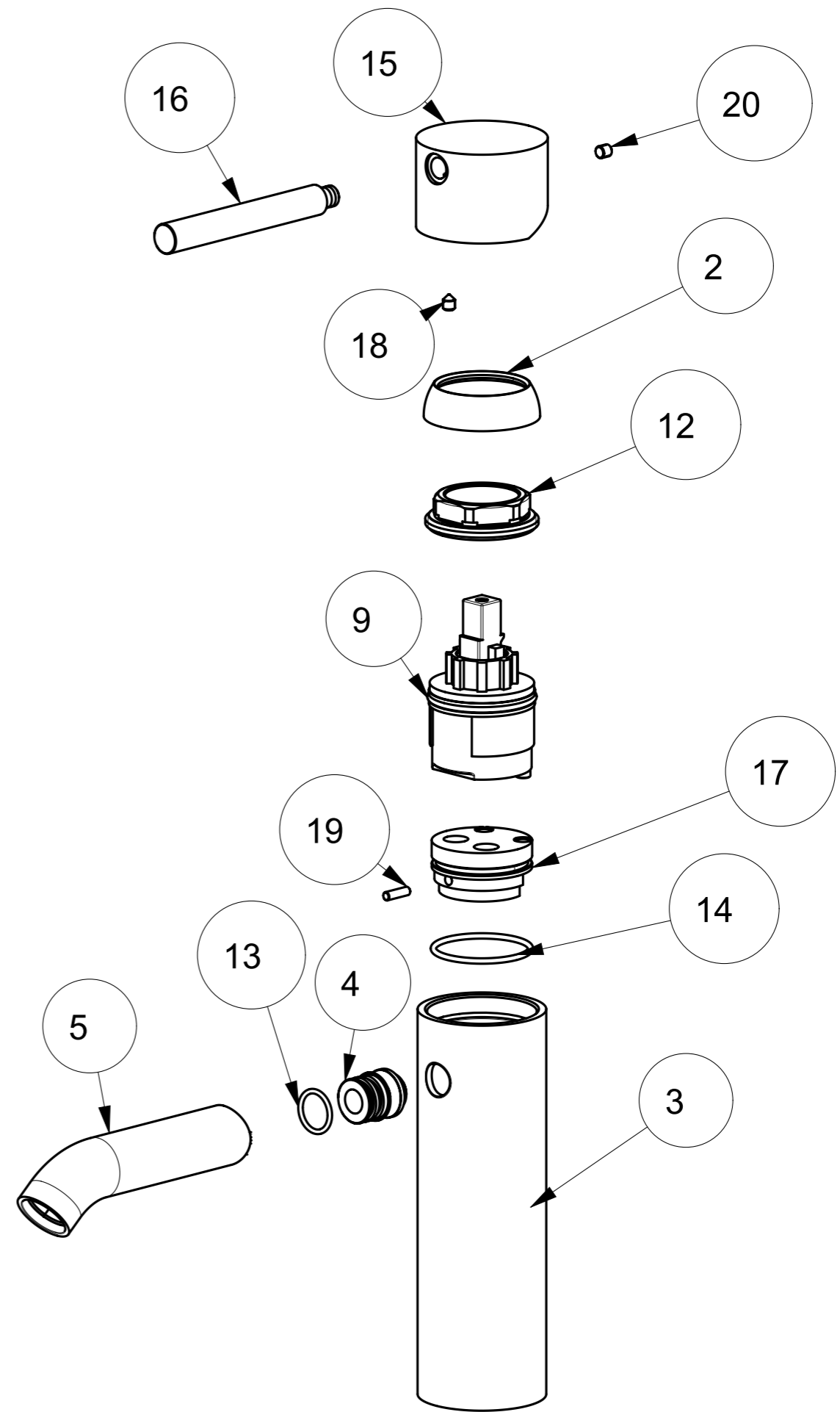

**AC8585**

Placca WC con pulsanti tondi.  
 Flush plate with two round buttons.  
 Plaque de déclenchement WC avec double bouton rond.  
 WC-Betätigungsplatte mit zwei runden Tasten  
 Placa de descarga WC con doble pulsador redondo.

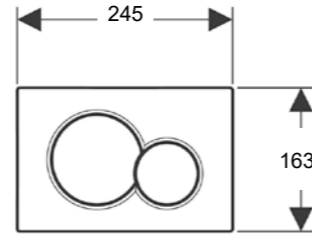

PLACCA COMPATIBILE CON  
 MODELLO SIGMA01

PLATE COMPATIBLE WITH  
 MODEL SIGMA01

Collezione Primavera € 200,00

**AC8586**

Placca WC con pulsanti quadrati.  
 Flush plate with two square buttons  
 Plaque de déclenchement WC avec double bouton carré.  
 WC-Betätigungsplatte mit zwei rechteckigen Tasten.  
 Placa de descarga WC con doble pulsador rectangular.

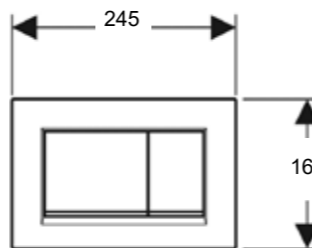

PLACCA COMPATIBILE CON  
 MODELLO SIGMA30

PLATE COMPATIBLE WITH  
 MODEL SIGMA30

Collezione Primavera € 325,00

**AC0042**

Supporti per bordo vasca attacco da 3/4" h. 64.  
 Legs for deck mounted bath mixer set 3/4" h. 64.  
 Couple raccords colonnettes 3/4" h. 64.  
 Halterungen für Wannenrandarmatur 3/4" h. 64.  
 Soportes para borde de bañera, conexión de 3/4" h. 64.

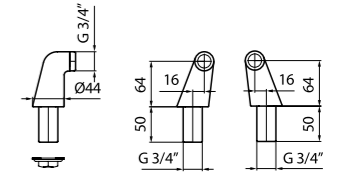

.015 Cromo / Chrome / Chromée / Verchromt / Cromado € 43,00  
 .010 Oro / Gold / Doré / Gold / Oro € 59,00  
 .065 Bronzato / Bronze / Bronze / Bonze / Bronze € 51,00

**AC0043**

Supporti per bordo vasca attacco da 3/4" h. 125.  
 Legs for deck mounted bath mixer set 3/4" h. 125.  
 Couple raccords colonnettes 3/4" h. 125.  
 Halterungen für Wannenrandarmatur 3/4" h. 125.  
 Soportes para borde de bañera, conexión de 3/4" h. 125.

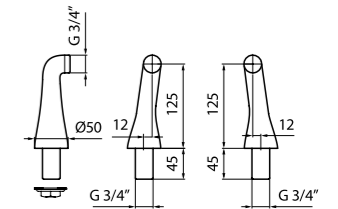

.015 Cromo / Chrome / Chromée / Verchromt / Cromado € 65,00  
 .010 Oro / Gold / Doré / Gold / Oro € 85,00  
 .065 Bronzato / Bronze / Bronze / Bonze / Bronze € 78,00

**AC0044**

Supporti a pavimento per gruppo vasca esterno.  
 Floor connections for bath mixer.  
 Raccords sur pieds pour bain/douche.  
 Standverschraubungen für Badebatterie.  
 Columnas de toma de agua de suelo.

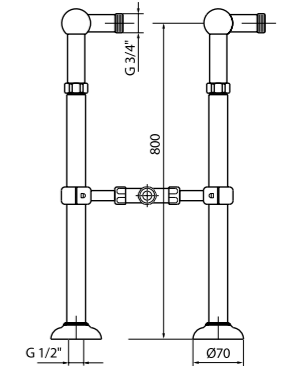

.015 Cromo / Chrome / Chromée / Verchromt / Cromado € 529,00  
 .010 Oro / Gold / Doré / Gold / Oro € 698,00  
 .065 Bronzato / Bronze / Bronze / Bonze / Bronze € 698,00

**AC0045**

Supporti a pavimento per gruppo vasca esterno.  
 Floor connections for bath mixer.  
 Raccords sur pieds pour bain/douche.  
 Standverschraubungen für Badebatterie.  
 Columnas de toma de agua de suelo.

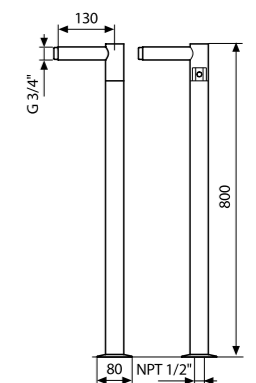

.015 Cromo / Chrome / Chromée / Verchromt / Cromado € 442,00

## AC0033



Colonna di scarico per vasca automatica con calotta e curva.

Pop-up bath tube waste with tail.

Vidage automatique à câble pour baignoire.

Ab- und Überlaufgarnitur für Badewanne.

Desagüe bañera con desagüe automático.

.015	Cromo / Chrome / Chromée / Verchromt / Cromado	€ 77,00
.010	Oro / Gold / Doré / Gold / Oro	€ 118,00
.065	Bronzato / Bronze / Bronze / Bonze / Bronze	€ 115,00
.980	Oro rosa / Rose gold / Or rose / Rosegold / Oro rosa	€ 155,00

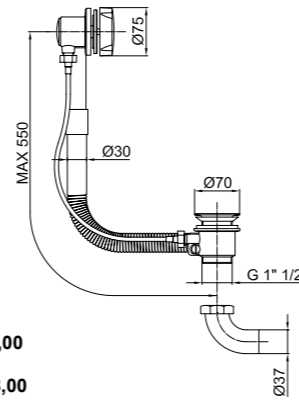

## AC0021



Sifone a bottiglia da 1" 1/4 regolabile.

Adjustable bottle siphon 1" 1/4.

Siphon 1" 1/4 avec tube de réglage.

Flaschensiphon 1" 1/4".

Sifón de 1" 1/4 regulable.

.015	Cromo / Chrome / Chromée / Verchromt / Cromado	€ 28,00
.010	Oro / Gold / Doré / Gold / Oro	€ 125,00
.065	Bronzato / Bronze / Bronze / Bonze / Bronze	€ 111,00

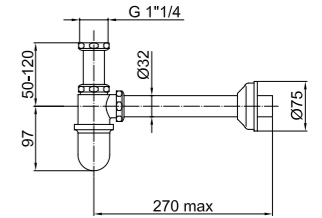

## AC0034



Colonna di scarico per vasca automatica con erogazione dal troppo pieno e curva.

Pop-up bath tube waste with overflow.

Vidage automatique à câble pour baignoire avec trop-plein.

Ab- und Überlaufgarnitur für Badewanne mit Tropfflächenauflauf.

Desagüe bañera con llenado en el rebosadero y desagüe automático.

.015	Cromo / Chrome / Chromée / Verchromt / Cromado	€ 130,00
.010	Oro / Gold / Doré / Gold / Oro	€ 189,00
.065	Bronzato / Bronze / Bronze / Bonze / Bronze	€ 186,00

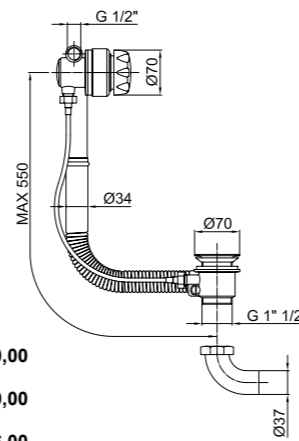

## AC0022



Sifone tipo "K" da 1" 1/4 con ispezione.

"K" siphon 1" 1/4 with inspection.

Siphon type "K" 1" 1/4 avec bouchon de visite.

"K" Röhrensiphon 1" 1/4.

Sifón a "K" de 1" 1/4 con abertura.

.015	Cromo / Chrome / Chromée / Verchromt / Cromado	€ 35,00
.010	Oro / Gold / Doré / Gold / Oro	€ 98,00
.065	Bronzato / Bronze / Bronze / Bonze / Bronze	€ 84,00

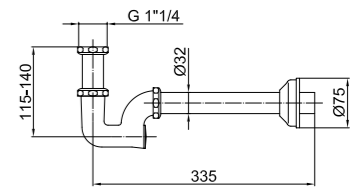

## AC0020



Sifone a bottiglia tubolare 1" 1/4.

Minimalist bottle siphon 1" 1/4.

Siphon tubulaire 1" 1/4.

Flaschensiphon 1" 1/4.

Sifón de 1" 1/4.

.015	Cromo / Chrome / Chromée / Verchromt / Cromado	€ 70,00
.560	Nero opaco / Matt black / Noir mat / Schwarz Matt / Negro mate	€ 98,00
.345	Simil acciaio / Steel / Acier brossé / Edelstahl Optik / Acero Cepillado	€ 112,00
.010	Oro / Gold / Doré / Gold / Oro	€ 140,00
.980	Oro rosa / Rose gold / Or rose / Rosegold / Oro rosa	€ 147,00
	Collezione Primavera	€ 126,00

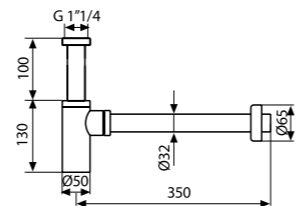

## AC0023

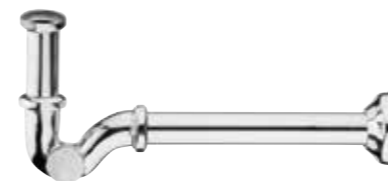

Sifone a "S" da 1" 1/4 con ispezione laterale.

"S" siphon 1" 1/4 side inspection.

Siphon "S" 1" 1/4 avec bouchon de visite.

"S" Röhrensiphon 1" 1/4.

Sifón a "S" de 1" 1/4 con abertura lateral.

.015	Cromo / Chrome / Chromée / Verchromt / Cromado	€ 35,00
.010	Oro / Gold / Doré / Gold / Oro	€ 98,00
.065	Bronzato / Bronze / Bronze / Bonze / Bronze	€ 84,00

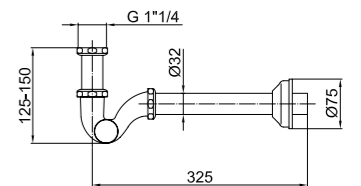

## AC0404



Sifone a bottiglia quadro 1" 1/4.

Minimalist bottle siphon 1" 1/4.

Siphon 1" 1/4.

Flaschensiphon 1" 1/4.

Sifón de 1" 1/4.

.015	Cromo / Chrome / Chromée / Verchromt / Cromado	€ 85,00
.560	Nero opaco / Matt black / Noir mat / Schwarz Matt / Negro mate	€ 136,00
.345	Simil acciaio / Steel / Acier brossé / Edelstahl Optik / Acero Cepillado	€ 153,00
.010	Oro / Gold / Doré / Gold / Oro	€ 170,00
	Collezione Primavera	€ 159,00

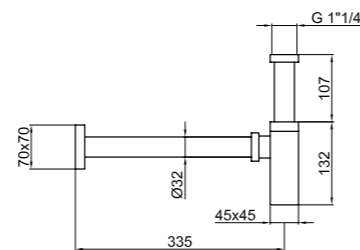

## AC0406



Scarico da 1" 1/4 per lavabo e bidet.

1" 1/4 Pop-up waste for washbasin and bidet mixer.

Garniture de vidage 1" 1/4 pour lavabo et bidet.

Ablaufgarnitur 1" 1/4 für Waschtisch- und Bidetbatterie.

Desagüe de 1" 1/4 para lavabo y bidet.

.015	Cromo / Chrome / Chromée / Verchromt / Cromado	€ 21,00
.010	Oro / Gold / Doré / Gold / Oro	€ 43,00
.065	Bronzato / Bronze / Bronze / Bonze / Bronze	€ 43,00
.025	Bianco / White / Blanc / Weiss / Blanco	€ 25,00

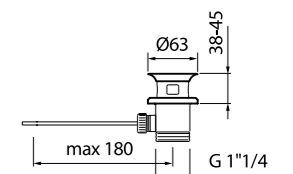

## AC0405



Scarico automatico (up & down) con troppo pieno 1"1/4.  
 1"1/4 "Up & down" automatic pop-up waste with overflow.  
 Vidage automatique 1"1/4 "Up & down" avec trop-plein.  
 Ablaufventil "Up & Down" 1"1/4 mit Ueberlauf.  
 válvula click-clack con rebosadero de 1"1/4.

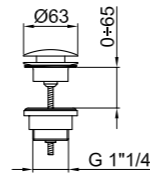

.015 Cromo / Chrome / Chromée / Verchromt / Cromado € 51,00  
 .010 Oro / Gold / Doré / Gold / Oro € 112,00

## AC0026



Copriforo per lavabo e bidet Ø 50.  
 Plug for washbasin and bidet mixer Ø 50.  
 Rosace cache-trou pour lavabo et bidet Ø 50.  
 Deckrosette für Waschtisch und Bidetbatterie Ø 50.  
 Cubreorificio para lavabo y bidet Ø 50.

.015 Cromo / Chrome / Chromée / Verchromt / Cromado € 11,00

## AC0032



Rubinetto sottolavabo con filtro.  
 Angle tap with filter.  
 Robinet à filtre sous lavabo.  
 Eckventil mit filter.  
 Llave escuadra con filtro.

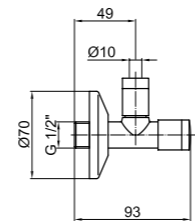

.015 Cromo / Chrome / Chromée / Verchromt / Cromado € 50,00

## AC0118



Rubinetto sottolavabo con filtro.  
 Angle tap with filter.  
 Robinet à filtre sous lavabo.  
 Eckventil mit filter.  
 Llave escuadra con filtro.

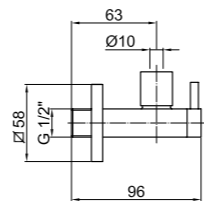

.015 Cromo / Chrome / Chromée / Verchromt / Cromado € 220,00

## AC0028



Rubinetto con filtro sottolavabo.  
 Angle tap with filter.  
 Robinet à filtre sous lavabo.  
 Eckventil mit Filter.  
 Llave escuadra con filtro.

.015 Cromo / Chrome / Chromée / Verchromt / Cromado € 16,00  
 .010 Oro / Gold / Doré / Gold / Oro € 62,00  
 .065 Bronzato / Bronze / Bronze / Bonze / Bronze € 44,00  
 .560 Nero opaco / Matt black / Noir mat / Schwarz Matt / Negro mate € 41,00

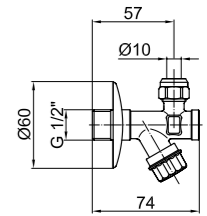

## AC0029



Rubinetto sottolavabo.  
 Angle tap.  
 Robinet sous lavabo.  
 Eckventil.  
 Llave escuadra.

.015 Cromo / Chrome / Chromée / Verchromt / Cromado € 11,00  
 .010 Oro / Gold / Doré / Gold / Oro € 55,00  
 .065 Bronzato / Bronze / Bronze / Bonze / Bronze € 38,00

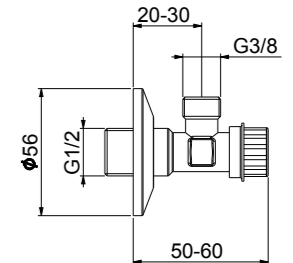

## AC0418



Eccentrico completo standard.  
 Complete standard S-connection with cover plate.  
 Rosace complete standard.  
 Kompletter standard S-Anschluss mit Rosette.  
 Excéntrica standard.

.015 Cromo / Chrome / Chromée / Verchromt / Cromado € 6,00  
 .010 Oro / Gold / Doré / Gold / Oro € 15,00  
 .065 Bronzato / Bronze / Bronze / Bonze / Bronze € 8,00  
 .025 Bianco / White / Blanc / Weiss / Blanco € 13,00

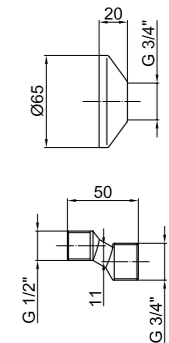

## AC0421

Eccentrico completo OTTOCENTO-KARENINA-ALEXANDRA-DORIAN.

Complete S-connection with cover plate OTTOCENTO-KARENINA-ALEXANDRA-DORIAN.

Rosace complete OTTOCENTO-KARENINA-ALEXANDRA-DORIAN.

Kompletter S-Anschluss mit Rosette OTTOCENTO-KARENINA-ALEXANDRA-DORIAN.

Excéntrica OTTOCENTO-KARENINA-ALEXANDRA-DORIAN.

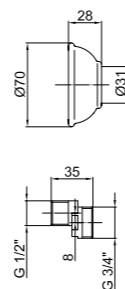

.015 Cromo / Chrome / Chromée / Verchromt / Cromado € 30,00

.010 Oro / Gold / Doré / Gold / Oro € 60,00

.065 Bronzato / Bronze / Bronze / Bonze / Bronze € 54,00

## AC0838

Doccetta per cucina.

Pull-down spray for kitchen mixer.

Douchette pour mitigeur d'évier.

Geschirrbrause für Küchenarmatur.

Ducha para cocina.



.015 Cromo / Chrome / Chromée / Verchromt / Cromado € 58,00

## AC0435

Doccetta per cucina.

Pull-down spray for kitchen mixer.

Douchette pour mitigeur d'évier.

Geschirrbrause für Küchenarmatur.

Ducha para cocina.



.015 Cromo / Chrome / Chromée / Verchromt / Cromado € 41,00

## AC0445

Tubetto di rame Ø 10 cm 35 M10x1.

Copper pipe Ø 10 cm 35 M10x1.

Tube cuivre Ø 10 cm 35 M10x1.

Kupferrohr Ø 10 cm. 35 M10x1.

Tubo de cobre, Ø 10, longitud 35 cm, M10x1.



Cromo / Chrome / Chromée / Verchromt / Cromado € 11,00

Oro / Gold / Doré / Gold / Oro € 20,00

Bronzato / Bronze / Bronze / Bonze / Bronze € 19,00

## AC0446

Flex in acciaio inox cm 37; attacco da 3/8" F. -M10x1 DN6 completo di guarnizione.

3/8" F. Flexible hose cm 37, -M10x1 DN6.

Flexible d'alimentation cm 37, 3/8" F. -M 10x1, DN6.

Flex. Anschlussschlauch cm 37, 3/8" F. -M10x1 DN6.

Tubo flexible de acero inoxidable, longitud 37 cm, de 3/8" F. -M10x1 DN6 con junta.



CM 37 AC0446000 € 4,00

CM 50 AC0447000 € 7,00

CM 70 AC0448000 € 9,00

## AC0449

Flex in acciaio inox cm 37; attacco da 1/2" F. -M10x1 DN6 completo di guarnizione.

1/2" F. Flexible hose cm 37, -M10x1 DN6.

Flexible d'alimentation cm 37, 1/2" F. -M 10x1, DN6.

Flex. Anschlussschlauch cm 37, 1/2" F. -M10x1 DN6.

Tubo flexible de acero inoxidable, longitud 37 cm, de 1/2" F. -M10x1 DN6 con junta.



CM 37 AC0449000 € 5,00

CM 50 AC0450000 € 8,00

CM 70 AC0451000 € 10,00

## AC0452

Flex in acciaio inox cm 37; attacco da 3/8" F. -M 8x1 DN6 completo di guarnizione.

3/8" F Flex. hose cm 37 -M 8x1 DN6.

Flexible d'alimentation cm 37 3/8" F.-M 8x1 DN6.

3/8" Flex. Anschlussschlauch cm. 37 M 8x1 DN6.

Tubo flexible de acero inoxidable, longitud 37 cm, de 3/8" F.-M 8x1 DN6 con junta.



CM 37 AC0452000 € 4,00

CM 50 AC0453000 € 6,00

CM 70 AC0454000 € 9,00

## AC0455

Flex in acciaio inox cm 37; attacco da 1/2" F. -M 8x1 DN6 completo di guarnizione.

1/2" F Flexible hose cm 37 -M 8x1 DN6.

Flexible d'alimentation cm 37 1/2" F. -M 8x1 DN6.

1/2" F Flex. Anschlussschlauch cm 37 -M 8x1 DN6.

Tubo flexible de acero inoxidable, longitud 37 cm de 1/2" F. -M 8x1 DN6 con junta.



CM 37 AC0455000 € 7,00

CM 50 AC0456000 € 9,00

CM 70 AC0457000 € 11,00

**AC0505**

Canna tipo "S" interasse 200/300 mm.  
 Swivel "S" spout 200/300 mm.  
 Bec mobile modèle "S" 200/300 mm.  
 "S" Schwenkrohrauslauf 200/300 mm.  
 Caño en forma de "S", distancia entre los ejes 200/300 mm.

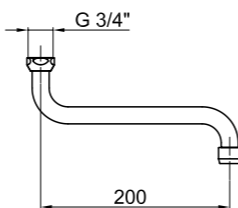

.015 Cromo / Chrome / Chromée / Verchromt / Cromado € 17,00

**AC0474**

Canna idroformata tipo "S" interasse 200 mm.  
 Swivel forged "S" spout 200 mm.  
 Bec mobile idroformée "S" 200 mm.  
 "S" Schwenkrohrauslauf Auslauf 200 mm.  
 Caño hidroformado en forma de "S", distancia entre los ejes 200 mm.

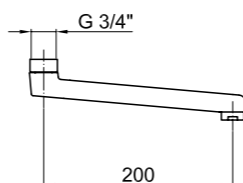

.015 Cromo / Chrome / Chromée / Verchromt / Cromado € 28,00

**AC0462**

Aeratore M 24x1.  
 Aerator M 24x1.  
 Aérateur complet M 24x1.  
 Mischdüse M 24x1.  
 Aireador M 24x1.



.015 Cromo / Chrome / Chromée / Verchromt / Cromado € 3,00

.010 Oro / Gold / Doré / Gold / Oro € 5,00

.065 Bronzato / Bronze / Bronze / Bonze / Bronze € 5,00

**AC0463**

Aeratore M 28x1.  
 Aerator M 28x1.  
 Aérateur complet M 28x1.  
 Mischdüse M 28x1.  
 Aireador M 28x1.



.015 Cromo / Chrome / Chromée / Verchromt / Cromado € 4,00

.010 Oro / Gold / Doré / Gold / Oro € 9,00

.065 Bronzato / Bronze / Bronze / Bonze / Bronze € 9,00

**AC0464**

Aeratore G3/8 Ø 18,5 completo di snodo per bidet ELIO - OPERA.  
 Aerator with ball-joint G3/8 Ø 18,5 for bidet ELIO - OPERA.  
 Aérateur avec rotule G3/8 Ø 18,5 pour bidet ELIO - OPERA.  
 Mischdüse mit Kugelgelenk G3/8 Ø 18,5 für Bidet ELIO - OPERA.  
 Aireador G3/8 Ø 18,5 articulado para bidet ELIO - OPERA.



.015 Cromo / Chrome / Chromée / Verchromt / Cromado € 16,00

**AC0465**

Aeratore M 22x1 completo di snodo per bidet.  
 Aerator with ball-joint M 22x1 for bidet.  
 Aérateur avec rotule M22x1 pour bidet.  
 Mischdüse mit Kugelgelenk M 22x1 für Bidet.  
 Aireador M 22x1 articulado para bidet.



.015 Cromo / Chrome / Chromée / Verchromt / Cromado € 7,00

.010 Oro / Gold / Doré / Gold / Oro € 11,00

.065 Bronzato / Bronze / Bronze / Bonze / Bronze € 11,00

**AC0470**

Aeratore WOLO caché M 24x1 con chiave.  
 Aerator WOLO caché M 22x1 with key.  
 Aérateur WOLO caché M 22x1 avec clé.  
 Mischdüse WOLO caché M 22x1 mit Schlüssel.  
 Aireador WOLO caché M 22x1 con llave.



.000 Neutro / Neutral / Neutre / Neutral / Neutral € 8,00

**AC0471**

Aeratore 360° caché M 21,5x1 con chiave.  
 Aerator 360° caché M 21,5x1 with key.  
 Aérateur 360° caché M 21,5x1 avec clé.  
 Mischdüse 360° caché M 21,5x1 mit Schlüssel.  
 Aireador 360° caché M 21,5x1 con llave.



.000 Neutro / Neutral / Neutre / Neutral / Neutral € 8,00

**AC1196**

Cartuccia Ø 35 con distributore 1 piolo.  
 Ceramic cartridge Ø 35 with distributor 1 foot.  
 Cartouche céramique Ø 35 avec distributeur.  
 Keramik-Kartusche Ø 35 mit Verteiler.  
 Cartucho Ø 35 con distribuidor.

.000 Neutro / Neutral / Neutre / Neutral / Neutral € 13,00

**AC1134**

Cartuccia Ø 42 mm senza distributore.

Ceramic cartridge Ø 42 mm without distributor.

Cartouche céramique Ø 42 mm sans distributeur.

Keramik-Kartusche Ø 42 mm ohne Verteiler.

Cartucho Ø 42 mm sin distribuidor.

.000 Neutro / Neutral / Neutre / Neutral / Neutral € 13,00

**AC1132**

Cartuccia Ø 25 mm per serie Pegaso e Ombra.

Ceramic cartridge Ø 25 mm for Pegaso and Ombra series..

Cartouche céramique Ø 25 mm pour Pegaso et Ombra.

Keramik-Kartusche Ø 25 mm Pegaso und Ombra.

Cartucho Ø 25 mm para Pegaso y Ombra.

.000 Neutro / Neutral / Neutre / Neutral / Neutral € 20,00

**AC1034**

Cartuccia Ø 25 mm 90° antioraria

Ceramic cartridge Ø 25 mm 90° anti-clockwise opening.

Cartouche céramique Ø 25 mm 90° antihoraire.

Keramik-Kartusche Ø 25 mm 90° links öffnend

Cartucho Ø 25 mm 90° antihorario.

.000 Neutro / Neutral / Neutre / Neutral / Neutral € 20,00

**AC0355****AC0267 WOLO**

Cartuccia AZETA Ø 25.

Ceramic cartridge AZETA Ø 25.

Cartouche céramique AZETA Ø 25.

Keramik-Kartusche AZETA Ø 25.

Cartucho AZETA Ø 25.

AC0355 .000 Neutro / Neutral / Neutre / Neutral / Neutral € 20,00

AC0267 .000 Neutro / Neutral / Neutre / Neutral / Neutral € 40,00

**AC0684**

Cartuccia ø25 aperta (lavabo ARIA standard).

Open cartridge ø25 (ARIA standard washbasin).

Cartouche ouverte ø25 (mitigeur de lavabo standard ARIA).

Offene Mischdüse ø25 (ARIA Standard Waschtischmischer).

Cartucho ø25 abierto (lavabo ARIA standard).

.000 Neutro / Neutral / Neutre / Neutral / Neutral € 60,00

**AC0977**

Cartuccia Ø 35 senza distributore (OPERA-BYBLOS-ELIO-DO RE MI).

Ceramic cartridge Ø 35 without distributor (OPERA-BYBLOS-ELIO-DO RE MI).

Cartouche céramique Ø 35 sans distributeur (OPERA-BYBLOS-ELIO-DO RE MI).

Keramik-Kartusche Ø 35 ohne Verteiler (OPERA-BYBLOS-ELIO-DO RE MI).

Cartucho Ø 35 sin distribuidor (OPERA-BYBLOS-ELIO-DO RE MI).

.000 Neutro / Neutral / Neutre / Neutral / Neutral € 20,00

**AC0361**

Cartuccia Ø 35 con distributore.

Ceramic cartridge Ø 35 with distributor.

Cartouche céramique Ø 35 avec distributeur.

Keramik-Kartusche Ø 35 mit Verteiler.

Cartucho Ø 35 con distribuidor.

.000 Neutro / Neutral / Neutre / Neutral / Neutral € 13,00

**AC0338**

Cartuccia Ø 35 senza distributore.

Ceramic cartridge Ø 35 without distributor.

Cartouche céramique Ø 35 sans distributeur.

Keramik-Kartusche Ø 35 ohne Verteiler.

Cartucho Ø 35 sin distribuidor.

.000 Neutro / Neutral / Neutre / Neutral / Neutral € 13,00

**AC0335**

Deviatore a cartuccia Ø 40, 3 vie (WOLO - ARIA).

3-ways diverter with ceramic discs Ø 40 (WOLO - ARIA).

Inverseur 3-voies avec disques céramiques Ø 40 (WOLO - ARIA).

3-Weg Umsteller mit keramischen Scheiben Ø 40 (WOLO - ARIA).

Desviador de cartucho Ø 40, 3 vías (WOLO - ARIA).

.000 Neutro / Neutral / Neutre / Neutral / Neutral € 38,00

**AC0312**

Cartuccia Ø 35 senza distributore, con limitatore di portata-temperatura ed asta ottone (WOLO).

Ceramic cartridge Ø 35 without distributor, with brass rod (WOLO).

Cartouche céramique Ø 35 sans distributeur, avec tige en laiton (WOLO).

Keramik-Kartusche Ø 35 ohne Verteiler, mit Messinghebel (WOLO).

Cartucho Ø 35 sin distribuidor, con varilla de latón (WOLO).

.000 Neutro / Neutral / Neutre / Neutral / Neutral € 28,00

**AC0329**

Deviatore a cartuccia 2 vie Ø 35 con asta ottone (ELIO).  
 2-ways diverter with brass rod Ø 35 (ELIO).  
 Inverseur 2-voies avec tige en laiton Ø 35 (ELIO).  
 2-Weg Umsteller mit Messinghebel Ø 35 (ELIO).  
 Desviador de cartucho Ø 35, 2 vías, con varilla de latón (ELIO).

.000 Neutro / Neutral / Neutre / Neutral / Neutral € 26,00

**AC0855**

Cartuccia termostatica (LIVING).  
 Cartridge for thermostatic mixer (LIVING).  
 Cartouche pour mitigeur thermostatique (LIVING).  
 Thermostat-Kartusche (LIVING).  
 Cartucho termostático (LIVING).

.000 Neutro / Neutral / Neutre / Neutral / Neutral € 72,00

**AC0330**

Cartuccia termostatica (WOLO).  
 Cartridge for thermostatic mixer (WOLO).  
 Cartouche pour mitigeur thermostatique (WOLO).  
 Thermostat-Kartusche (WOLO).  
 Cartucho termostático (WOLO).

.000 Neutro / Neutral / Neutre / Neutral / Neutral € 70,00

**AC0331**

Vitone 1/2" 90° DX a dischi ceramici broccia 8X20.  
 1/2" ceramic upperpart right 90°.  
 Tête céramique 1/2" droite 90°.  
 1/2" keramik-Oberteil rechts 90°.  
 Montura 1/2", 90° DX de discos cerámicos.

.000 Neutro / Neutral / Neutre / Neutral / Neutral € 16,00

**AC0332**

Vitone 1/2" 90° SX a dischi ceramici broccia 8x20.  
 1/2" ceramic upperpart left 90°.  
 Tête céramique 1/2" droite 90°.  
 1/2" keramik-Oberteil rechts 90°.  
 Montura 1/2", 90° SX de discos cerámicos.

.000 Neutro / Neutral / Neutre / Neutral / Neutral € 16,00

**AC0325**

Vitone 1/2"90°DX regolabile a dischi ceramici broccia 8x20 (LIVING - ARIA).  
 1/2" ceramic upperpart right 90° (LIVING - ARIA).  
 Tête céramique 1/2" droite 90° (LIVING - ARIA).  
 1/2" keramik-Oberteil rechts 90° (LIVING - ARIA).  
 Montura 1/2", 90° DX de discos cerámicos (LIVING - ARIA).

.000 Neutro / Neutral / Neutre / Neutral / Neutral € 19,00

**AC0326**

Vitone 1/2" 90° SX regolabile a dischi ceramici broccia 8x20 (LIVING - ARIA).  
 1/2" ceramic upperpart left 90° (LIVING - ARIA).  
 Tête céramique 1/2" droite 90° (LIVING - ARIA).  
 1/2" keramik-Oberteil rechts 90° (LIVING - ARIA).  
 Montura 1/2", 90° SX de discos cerámicos (LIVING - ARIA).

.000 Neutro / Neutral / Neutre / Neutral / Neutral € 19,00

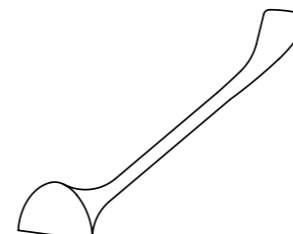
**AC0475**

Leva tipo "CLINICA" ø 40.  
 Sanitary lever ø 40.  
 Poignée clinique ø 40.  
 Klinik Hebel ø 40.  
 Maneta medical ø 40.

.015 Cromo / Chrome / Chromée / Verchromt / Cromado € 15,00

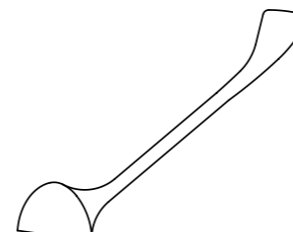
**AC1158**

Leva tipo "CLINICA" ø 35.  
 Sanitary lever ø 35.  
 Poignée clinique ø 35.  
 Klinik Hebel ø 35.  
 Maneta medical ø35.

.015 Cromo / Chrome / Chromée / Verchromt / Cromado € 17,00



## QUALITÀ CERTIFICATA / CERTIFIED QUALITY / QUALITÉ CERTIFIÉE QUALITÄT MIT ZERTIFIKAT / CALIDAD CERTIFICADA

Tra i valori che formano le principali caratteristiche di Webert vi è la qualità di processo e di prodotto. Non concetti astratti ma realtà vissuta pienamente e certificata da primari enti internazionali preposti.

The procedure and product quality is the value that is Webert main characteristic.  
Not abstract concepts, but a real situation certified by primary international accredited companies.

Parmi les valeurs qui constituent les principales caractéristiques de Webert, il ya la qualité de processus et de produit. Il ne s'agit pas de concepts abstraits mais d'une réalité concrète et certifiée par des premiers organismes internationaux.

Zu den wichtigsten Werten, die charakteristisch für WEBERT sind, zählen Qualität in Prozess und Produkt. Keine abstrakten Begriffe, sondern gelebte Wirklichkeit, bestätigt von führenden, international anerkannten Prüfanstalten.

Entre los valores que forman las principales características de Webert, hay la calidad de proceso y producto. Ningun conceptos abstractos, sino realidad experimentada y certificada para las mas importantes marcas de



## CROMATURA / CHROME PLATING / CHROMAGE VERCHROMUNG / CROMADO

La qualità dei rivestimenti superficiali è di fondamentale importanza per garantire nel tempo la durata del prodotto; per ottenere un ottimo trattamento l'intero processo galvanico di cromatura è realizzato internamente all'azienda con tecnologie moderne e costantemente aggiornate.  
L'impianto di depurazione, collegato a quello di produzione, utilizza sistemi a "scarico zero" che limitano l'impatto ambientale al minimo.

The quality of the coating surfaces is very important to guarantee the working life of the product: in order to obtain a perfect result all galvanic processes are completely carried out inside the factory, using modern technologies being continuously updated.  
The depuration plant is connected to the manufacturing machinery and uses "zero waste" methods thus reducing the environmental impact.

La qualité des revêtements des surfaces est très importante pour garantir dans le temps la durée du produit: pour obtenir un excellent traitement, tout le processus galvanique de chromage est réalisé totalement auprès de notre usine avec des technologies modernes et mises à jours.  
L'implantation de dépuraton relié à celui de la production utilise des systèmes avec « déchargement zéro » qui limitent au minimum l'impact sur l'environnement.

Die Qualität der oberflächigen Beschichtung ist sehr wichtig, damit ist die Dauer des Produktes garantiert; um ein sehr gute Behandlung zu haben, wird der komplette galvanische Verchromungsprozess innen der Firma mit modernen und aktualisierten Technologien durchgeführt.  
Der Reinigungsprozess, mit der Produktionsanlage verbunden, benutzt „Null-Abfluss“ Methoden, die die Umweltauswirkungen beschränken.

La calidad de los revestimientos superficiales es fundamental para garantizar la duración del producto. El proceso de galvanizado es hecho en el interior de la empresa y se cumple con tecnologías modernas y actualizadas. La depuradora es conectada a la instalación de producción y utiliza una forma "descarga cero" que limita el impacto ecológico.



## OTTONE / BRASS / LAITON / MESSING / LATÓN

Tutte le gamme di prodotti WEBERT sono caratterizzate dall'impiego di materie prime di primissima qualità. Gli ottoni utilizzati nei processi di fusione, stampaggio e lavorazioni meccaniche sono contraddistinti da un basso contenuto di piombo osservando i limiti imposti dalle attuali Normative Internazionali applicate alle acque destinate al consumo umano.

All ranges of Webert products are characterized by the use of first quality raw materials. The brass metal used for casting, forging and mechanical operations contains a very low percentage of lead in compliance with the levels fixed by the present International Norms applied to the drinking water.

Toutes les gammes de produits Webert sont caractérisées par l'emploi de matières premières de haute qualité. Le laiton utilisé dans les processus de fusion, matriçage et usinage est caractérisé par un bas pourcentage de plomb en respectant les limites imposées par les normes internationales actuelles appliquées aux eaux potables.

Das gesamte Sortiment zeichnet sich durch beste Qualität der Rohmaterialien aus. Das Metall wird aus einem Guss gefertigt und maschinell verarbeitet. Das Material entspricht genau den internationalen Normen sowie der Trinkwasserordnung.

Todas las gamas de productos WEBERT son caracterizadas por la utilización de materias primas de primera calidad. Los latones empleados en los procesos de fusión, moldeo y elaboraciones mecánicas se distinguen por un bajo contenido de plomo, observando los límites puestos por las actuales normativas internacionales, aplicadas en las aguas para consumo humano.



## VERNICIATURA / PAINTING / VERNISSAGE / LACKIERUNG / PINTURA

I trattamenti di verniciatura vengono effettuati con l'impiego di polveri epossidiche atossiche che conferiscono ai prodotti un'ottima resistenza al graffio, all'umidità, alle condizioni ambientali aggressive e ai raggi UV.

The painting treatments are carried out using epoxidic and atoxic powders giving the products an excellent endurance against scratches, humidity, aggressive environmental conditions and UV rays.

Les traitements de vernissage sont effectués avec l'emploi de poudres époxydiques et atoxiques et donnent aux produits une excellente endurance aux égratignures, à l'humidité, aux conditions environnementales agressives et aux rayons UV.

Die Lackierungsbehandlungen sind mit dem Einsatz von epoxidischen und atoxischen Pulvern durchgeführt, die die Produkten gegen Kratzer, Feuchtigkeit, aggressiven Umweltbedingungen und UV Strahlen schützen.

Los tratamientos de pintura son efectuados por medio de polvos epoxidicos atóxicos que confieren una optima resistencia a los rasguños, a la humedad y a las condiciones medioambientales agresivas y a los rayos UV.



## FLESSIBILI ALIMENTAZIONE / FLEXIBLES HOSES / FLEXIBLES D'ALIMENTATION FLEXIBLE ANSCHLUSSSCHLÄUCHE / TUBOS FLEXIBLES DE ALIMENTACIÓN

I flessibili di alimentazione utilizzati nell'intera gamma WEBERT sono rispondenti a tutte le normative nazionali ed internazionali relative ai materiali a contatto con l'acqua potabile, tra le quali il DVGW KTW Classe A in Germania, il KIWA olandese, il certificato WRAS inglese, il SVGW svizzero, l'ACS francese, il NSF negli Stati Uniti e il Sai Global australiano.

The used flexible hoses into the full range of Webert products are in conformity with the national and international norms with regards to the materials in contact with drinking water, such as DVGW KTW Class A in Germany, the Dutsch KIWA, the English WRAS certificate, the Swiss SVGW, the french ACS, the NSF in the United States and the australian Sai Global product certification.

Les flexibles d'alimentation utilisés dans toute la gamme des produits Webert sont conformes à toutes les normes nationales et internationales qui concernent les matériaux en contact avec l'eau potable, parmi les autres: le DVGW KTW Classe A en Allemagne, le KIWA hollandais, le certificat WRAS anglais, le SVGW suisse, l'ACS français, le NSF aux EtatsUnis et l'australien Sai Global.

Die verwendeten flex. Anschlussschläuche im gesamten Sortiment entsprechen genau den nationalen und internationalen Normen. Diese entsprechen ebenfalls der Trinkwasserordnung. Deutschland DVGW KTW Klasse A, Holland KIWA, England WRAS Zertifikat, Schweiz SVGW, Frankreich ACS, Vereinigten Staaten NSF, Australien Sai Global Produktzertifikat.

Los flexibles de alimentación empleados en la entera gama WEBERT responden a todas las normativas nacionales y internacionales, que se refieren a los materiales en contacto con el agua potable, entre las cuales DVGW KTW Clase A en Alemania, KIWA en los Países Bajos, la certificación WRAS en Inglaterra, SVGW en Suiza, ACS en Francia, NSF en los Estados Unidos y Sai Global en Australia.



## IMBALLAGGIO / PACKAGING / EMBALLAGE / VERPACKUNG / EMBALAJES

Gli imballi sono accuratamente studiati per proteggere il prodotto e garantirne l'integrità e la qualità estetica fino al momento dell'installazione, soprattutto per prevenire danni durante il trasporto. Normalmente sono impiegate scatole di cartone microtriplo molto resistenti e internamente il prodotto è protetto da sagome in spugna.

The packaging is carefully prepared to protect the product and guarantee the integrity and the esthetical quality up to the installation, above all in order to prevent damages during transportation. Normally packaging consists of very resistant three folded carton boxes and internally the product is protected by sponges.

Les emballages ont été étudiés pour protéger le produit et lui garantir l'intégrité et la qualité esthétique jusqu'au moment de l'installation et surtout pour prévenir des dommages pendant le transport. Normalement on emploie des boîtes de carton micro-triple très résistantes et à l'intérieur, le produit est protégé par des profils d'éponge.

Die Verpackungen sind sorgfältig vorbereitet, um die den Produkt zu schützen und dessen Unversehrtheit und ästhetischen Qualität zu sichern, bis der Endverbraucher den Produkt montiert und vor allem um Schaden während des Transportes zu verhindern. Normalerweise werden sehr widerstandsfähige dreifache Kartonschachtel verwendet und innen ist der Produkt mit Schwammeinlagen geschützt.

Los embalajes son proyectados para proteger el producto y garantizar la integridad y la calidad estética hasta el momento de la instalación, sobre todo para prevenir danos durante el transporte. Las cajas empleadas son de cartón micro triple muy resistentes y el producto es protegido por medio de perfiles de esponja.



## CARTUCCE MISCELATRICI A DISCHI CERAMICI / CERAMIC CARTRIDGES CARTOUCHES À DISQUES CÉRAMIQUES / KERAMISCHE KARTUSCHEN CARTUCHOS CON DISCOS CERÁMICOS

Le cartucce miscelatrici impiegate nei prodotti WEBERT soddisfano le richieste delle più importanti normative internazionali. Le cartucce dia. 35 e dia. 40 SONO DOTATE DI UN DOPPIO DISPOSITIVO DI REGOLAZIONE DELLA PORTATA E DELLA TEMPERATURA, offrendo la possibilità all'utente finale di impostare i parametri in base alle proprie esigenze e condizioni di utilizzo PER UN EFFETTIVO RISPARMIO DI RISORSE ED ENERGETICO.

The ceramic cartridges used in Webert products meet the requirements of the most important international standards. The 35 and 40 Ø cartridges are equipped with a double control device of flow rates and temperature, enabling the consumer to adjust flow and temperature parameters according to his needs in order to save energy and resources.

Les cartouches employées dans les produits Webert sont conformes aux demandes des plus importantes réglementations internationales. Les cartouches de diamètre 35 et diamètre 40 ont un double dispositif de régulation DU débit et de la température, et offrent à l'utilisateur final d'établir les paramètres sur la base de ses exigences et conditions d'usage pour obtenir une effective économie énergétique et de ressources.

Die in Webert Produkte verwendeten keramische Kartuschen kommen den Forderungen der internationalen. Die 35 and 40 Ø kartuschen SIND MIT EINER DOPPELTEN VORRICHTUNG VERSEHEN, DIE DIE WASSERMENGE UND DIE TEMPERATUR REGULIERT, und das erlaubt den endverbraucher die parameter je nach bedarf anzulegen und verbrauchsbedingungen FÜR EINE EFFEKTIVE ERSPARUNG DER MATERIELLEN UND ENERGIEQUELLEN.

Los cartuchos empleados en los productos Webert satisfacen las mas severas normativas internacionales. Los cartuchos con diámetro 35 y 40 SON EQUIPADOS CON UN DISPOSITIVO DOBLE PARA LA REGULACIÓN DE CAUDAL Y TEMPERATURA y ofrecen la posibilidad de ajustar los parámetros en base a las propias exigencias y condiciones de utilización PARA PERMITIR UN EFECTIVO AHORRO DE RECURSOS Y DE ENERGÍA.



## INOX / INOX / INOX / INOX / INOX EDELSTAHL / ACERO INOX

I rubinetti più esclusivi della collezione Webert impiegano materiali con caratteristiche superiori rispetto gli ottoni ed in particolare utilizziamo l'acciaio INOX AISI 304 L che è il più indicato per l'acqua potabile.

The most exclusive taps of Webert collection are produced with materials of higher quality than those used for the brass products; we indeed use the INOX AISI 304 L steel, which is the most suitable for drinking water.

La robinetterie la plus exclusive de la collection Webert utilise des matériaux avec des caractéristiques supérieures par rapport au laiton et en particulier nous utilisons l'acier INOX AISI 304, qui est le plus indiqué pour l'eau potable.

Die mehr exklusive Armaturen von Webert Kollektion verwenden hochwertigere Rohmaterialien als Messing. Ins besonders wird Inox Edelstahl AISI 304 I verwendet, der für Trinkwasser empfohlen ist.

Para las griferías de las colecciones más exclusivas de Webert, se utilizan materiales con características superiores a los latones, en particular utilizamos el acero INOX AISI 304 que es el más indicado para el agua potable.



## PARTE INTERNA INCASSO / BUILT-IN PRODUCTS / ROBINETTERIE ENCASTREE / UNTERPUTZ-KÖRPER / GRIFERÍAS EMPOTRADA

Tutti i sistemi da incasso della gamma Webert hanno una doppia protezione: una parte è in polistirolo e protegge il rubinetto dal muro per evitare che la condensa s'infiltri lungo la parete e provochi macchie o distacco del rivestimento. Una seconda protezione è esterna e serve per proteggere le parti in finitura durante i lavori di installazione e di finitura del rivestimento.

All built-in systems of the Webert range have a double protection: a part is made of polystyrene and protects the tap from the wall, in order to avoid the condensate seeps into the wall, causing damp patches or the detachment of the coating. A further protection is external and is used to protect the finished parts during the installation or the coating finishing.

Tous les systèmes encastrés de la gamme Webert ont une double protection: une partie en polystyrène protège le robinet et empêche que le condensat s'infilte à travers les murs et soit cause de tâches ou de détachement du revêtement. Une deuxième protection est extérieure et sert pour la protection des parties finies pendant les travaux d'installation et du finissage du revêtement.

Alle die Unterputz-Systeme von Webert Kollektion haben einen Doppelschutz: ein Kasten aus Polystyrol der, die Armatur vom Wand schützt, um zu vermeiden, dass das Kondenswasser sich der Wand entlang infiltriert und Flecken oder Beschichtungsablösungen verursacht. Ein zweite Außenschutz, der die Armaturausführung während der Installation und bzw. Beschichtungsarbeiten schützt.

## Certificato di garanzia

Gentile Cliente:

La Webert Industry garantisce i propri prodotti per vizi di fabbricazione per cinque anni dalla data del documento fiscale comprovante l’acquisto, entro tale termine, in caso di accertato difetto di fabbricazione, la Webert Industry, provvederà, a suo insindacabile giudizio, alla sostituzione gratuita del pezzo o all’eliminazione dei vizi.

Rammentiamo che non sono garantiti i danni causati da:

Messa in opera non conforme, utilizzo anomalo o inadeguato, errata manutenzione, normale usura, impiego di prodotti di pulizia non adatti, urti generati da trasporti o mancanza di cura durante l’istallazione, gelo, parti estranee presenti nelle condutture.

La garanzia non sarà, inoltre, operante in mancanza della documentazione comprovante la data di acquisto e in nessun caso (la garanzia) da diritto alla rifusione di spese e risarcimenti da danni diretti e indiretti subiti dal cliente quali montaggio/smontaggio del prodotto, interventi tecnici da personale specializzato, sospensione dell’utilizzo del prodotto.

Disposizioni tecniche
1) È opportuno installare appositi filtri e addolcitori da pulire periodicamente a monte della rubinetteria.
2) Il filtro dell’aeratore deve essere pulito periodicamente.
3) Pulire esclusivamente il rubinetto con acqua e sapone asciugando con panno morbido, non utilizzare detersivi contenenti acidi, alcool, detersivi in polvere, paglie metalliche, spugne abrasive.
4) Effettuare il risciacquo delle tubazioni prima di installare il rubinetto.
5) Pressione d’uso consigliata: 2:5 bar
6) Pressione max: 8 bar
7) Temperatura acqua calda consigliata: 60°C
8) Temperatura acqua calda max: 70°C

### Certificat de garantie

La Webert Industry garantie ses produits contre tous défauts de fabrication pendant une période de 5 ans à partir de la date de la facture d’achat ; dans ce délai, au cas où on a constaté le défaut de fabrication, la Webert Industry décidera, selon son avis, de remplacer gratuitement ou réparer le produit.

La garantie ne couvre pas les dommages causés par :
Installation erronée du produit, utilisation non conforme où inadéquate, maintenance (entretien) erronée, usure normale, emploi de produits de nettoyage non appropriés, coups reçus pendant le transport ou mauvais entretien pendant l’installation, gel, corps étrangers présents dans les conduites.

La garantie ne sera pas valable si le client n’est pas en mesure de présenter les documents qui certifient la date d’achat. En aucun cas la garantie donne droit au remboursement des frais et dédommagement direct ou indirect que le client a eu pendant l’installation ou le démontage d’un produit ni elle couvre la prestation technique du personnel spécialisé ou si le produit reste inutilisé pendant longtems.

1) Il est opportun d’installer des filtres appropriés en installant la robinetterie et des adoucissants qui doivent être nettoyés périodiquement.
2) Le filtre de l’aérateur doit être nettoyé périodiquement
3) Le robinet doit être nettoyé seulement avec de l’eau tiède savonneuse et essuyé avec un linge souple, il ne faut pas utiliser des détergents avec de l’acide, alcool, poudres détergentes, paillettes métalliques et éponges abrasives.
4) Effectuer le rinçage des conduites avant d’installer le robinet.
5) Pression d’usage recommandée: 2:5 bar
6) Pression de service maximale: 8 bar
7) Température de l’eau chaude conseillée: 60° C
8) Température maximale de l’eau conseillée: 70° C

### Certificado de garantía

Estimado Cliente:

Webert Industry garantiza sus productos por vicios de fabricación, por cinco años a partir de la fecha del comprobante fiscal de la adquisición; durante dicho período, en caso de verificación de un defecto de fabricación, Webert Industry, procederá, a su juicio inapelable, a sustituir gratuitamente la pieza defectuosa o a eliminar los vicios existentes.

Le recordamos que no están cubiertos por la garantía los daños causados por: puesta en obra no conforme, utilización anómala o inadecuada, incorrecto mantenimiento, normal desgaste, utilización de productos de limpieza no apropiados, choques causados por negligencia durante el transporte y la instalación, hielo, cuerpos extraños presentes en la tubería.

La garantía no será válida, además, si no se posee el comprobante de compra que certifica la fecha, y en ningún caso (la garantía) da derecho a indemnización de gastos y resarcimientos de daños directos e indirectos, sufridos por el cliente, como montaje/desmontaje del producto, intervenciones técnicas realizadas por

## Guarantee certificate

Dear customer,

Webert Industry guarantees its products against manufacturing defects for five years from the date of the document certifying the purchase; within this period, in case of a stated defective product, Webert Industry may choose at its own discretion whether to repair or replace it.

The following cases aren’t covered by the aforesaid guarantee:
Wrong installation of product, Damages caused by improper use or bad care, Normal wear and tear, Use of unsuitable powders or creams, Damages caused by not careful transportation or an improper mounting, Ice or foreign parts in the piping.
This guarantee won’t be valid in case of missing documents certifying the purchase date.Any compensation for replacement expenses is excluded in case of direct or indirect damages suffured by customer, such as installation/disassembly of the product, technical intervention of skilled workers or not interruption of use of the product.

Technical devices
1) It is necessary to install suitable filters and water-softener to be kept duly cleaned
2) The filter of the aerator must be periodically cleaned
3) Tap must be cleaned exclusively using warm soapy water and dried with a soft cloth; don’t use powders or creams containing alcohol, acid, metal or abrasive-sponges.
4) Rinse the pipes before installing the tap
5) recommended operation pressure (unless products for Irland & UK, which are to be 0,1 upwards): 2:5 bar
6) Max operating pressure: 8 bar
7) Max operating temperature: 60° C
8) Max water temperature: 70°C

### Garantiekarte

Sehr geehrte Damen und Herren,
Webert Industry leistet auf all Ihre Produkte gegen mangelhafte Ware eine 5-jaehrige Garantie ab dem Kaufdatum. Vor Ablauf dieser Frist im Falle von festgestellten Herstellungsfehler, wird Webert Industry, nach eigener Wahl, für den kostenlosen Ersatz oder eine Reparatur der fehlerhaften Armatur sorgen.

Diese Garantie gilt nicht wenn der Schaden verursacht wird durch:
Fehlerhaften Installation, falsche, unsachgemäße Behandlung oder Bedienung, unsachgemäße Montage, unüblichen Gebrauch, gebrauch ungeeigneter Putzmittel, einwirkungen während des Transports oder nicht sorgfältige Installation, frost oder Schmutz in den Leitungen.
Diese Garantie ist nur gültig, mit dem dazugehörigen Kassenbeleg, der das Kaufdatum bestätigt. Auf keinem Fall berechtigt die Garantie jegliche Ersatzansprüche hinsichtlich fehlerhafte Installation des Produkts, Wartung und Reparaturen durch unbefugtes Personal oder wenn das Produkt nicht mehr in Verwendung ist.

Pflegeanleitungen und technische Daten
1) Wir empfehlen, an die Wasseranlage eine Filterarmatur oder mindestens ein Filter zu montieren, um den Eingang von Fremdkörpern zu vermeiden. Diese Filter müssen ab und zu gereinigt werden.
2) Der Filter der Mischdüse muss ab und zu gereinigt werden.
3) Reinigen sie die Armatur nur mit Wasser und Seife und trocknen sie diese mit einem weichen Tuch
4) Die Wasserleitungen gut durchspülen bevor die Armatur montiert ist.
5) Empfohlener Betriebsdruck: 2:5 bar
6) Maximaler Betriebsdruck: 8 bar
7) Empfohlene Warmwassertemperatur: 60° C
8) Maximale Warmwassertemperatur: 70°C

personal especializado y suspensión del uso del producto.

Disposiciones técnicas
1) Es oportuno instalar especificos filtros y descondensadores aguas arriba de la grifería; límpielos periódicamente.
2) El filtro del ventilador también se debe limpiar periódicamente.
3) Limpie el grifo exclusivamente con agua y jabón secándolo con un paño suave, no utilice detergentes que contengan ácidos o alcohol, detergentes en polvo ni esponjas metálicas o abrasivas.
4) Realice un enjuague de las tuberías antes de instalar el grifo.
5) Presión de uso aconsejada : 2 : 5 bar
6) Presión máx : 8 bar
7) Temperatura del agua caliente aconsejada : 60°C
8) Temperatura del agua máx. 70°C

## CONDIZIONI GENERALI DI VENDITA

LISTINO PREZZI
I prezzi indicati sono espressi in euro al netto dell’IVA e si intendono per merce resa franco nostro stabilimento di MAGGIORA e sono quelli vigenti alla data dell’ordine salva nostra diversa offerta scritta che prevarrà sulla presente condizione generale.
ACCETTAZIONE
Salva preventiva deroga scritta da noi proveniente e sottoscritta, tutti gli ordini si intendono accettati alle condizioni generali di vendita vigenti e, se pervenuti agli agenti saranno per noi vincolanti solamente a decorrere dalla nostra specifica approvazione.
TERMINI DI CONSEGNA
I termini di consegna si intendono sempre indicativi e mai perentori, anche in deroga a qualsivoglia diversa precisazione contenuta negli ordini ovvero nelle conferme d’ordine provenienti dal cliente.
Ritardi di consegna non daranno il diritto al cliente di annullare o ridurre l’ordine ne a qualsivoglia domanda di addebito o penale di sorta. I termini sono calcolati in giorni lavorativi al netto delle sospensioni determinate da caso fortuito, forza maggiore o da cause comunque riferibili al cliente.
PRODOTTI
I nostri prodotti sono progettati, fabbricati e collaudati nel rispetto delle seguenti norme:

- per la rubinetteria tradizionale UNI EN 200.
- per i miscelatori monocomando UNI EN 817.
TRASPORTI

La merce anche se spedita franco destino viaggia a rischio e pericolo dell’acquirente.Al destinatario, anche differente dall’acquirente compete a pena di decadenza la verifica della merce, del numero dei colli, dello stato dell’imballaggio all’atto del ritiro nonchè l’espressione delle eventuali riserve e contestazioni al vettore o allo spedizioniere. Eventuali differenti condizioni dovranno risultare da atto da noi sottoscritto a pena di nullità.

TOLLERANZE
Il campionario finiture è puramente indicativo e non è data garanzia di uniformità di colorazione tra diverse partite. Il conferimento degli ordini indica accettazione delle tolleranze di differenza colore.
È nostra facoltà modificare le caratteristiche tecniche e costruttive dei prodotti, con il solo limite della riduzione delle funzionalità garantite al prodotto.
RECLAMI
Reclami di qualunque genere dovranno pervenire esclusivamente alla nostra società non essendo legittimati a riceverli gli agenti ne alcun altro soggetto esterno alla nostra direzione vendite.

## GENERAL SALES CONDITIONS

PRICE-LIST
The indicated prices are expressed in Euro net of VAT and are valid for goods ex our factory in MAGGIORA and are in force on the date of order except for our written order, which will prevail these general conditions.
ACCEPTANCE
Besides our anticipated written and signed dispensation, all the orders will be accepted according to the general sales conditions in force and if they have been carried out to our agents, they will be binding only upon our specific approval.
DELIVERY TERMS
Delivery terms are always indicative and in a peremptory way, even in dispensation or whatever text written in the orders or in the order confirmation by the customer. Delays in delivery don’t give the customer the right to cancel or reduce the order nor to ask for a debit or a penalty. The terms have been calculated in working days without interruptions due to accidental case, to circumstances beyond our control or to causes reportable to the customer.

PRODUCTS
Our products are planned, manufactured and tested according to the following rules:
- for traditional taps and fittings UNI EN 200.
- for single lever mixers UNI EN 817.

TRANSPORTS
The goods are transported upon risk and danger of the purchaser, even if they have been sent franco destination.
The receiver, if different from the purchaser, has to check the goods, the number of parcels, the condition of packaging at receipt and has to express possible doubts and notifications directly to the shipping or forwarding agency. Other conditions than the nominated ones should be signed by us otherwise they will be declared null and void.
TOLERANCES
The finishing sampling is purely indicative and the uniformity of colouring among the different parties can’t be guaranteed. The assignment of the orders indicates the acceptance of the different colour tolerances.
It is our faculty to modify the technical and construction features of the products upon guaranteeing the functionality of the product.

COMPLAINTS
Complaints of whatever kind should be send exclusively to our company since our agents don’t have the right to receive them neither any other person external to the sales management.
Complaints regarding the delivered goods will be checked effectively only, if they have been paid completely.
The complaints should be carried out in a written and detailed from within 8 days

Reclami sui beni forniti saranno validamente proposti alla sola condizione che sia avvenuto il preventivo loro integrale pagamento.

I reclami dovranno pervenire in forma scritta e dettagliata a pena di inammissibilità entro 8 giorni dal ricevimento della merce, salvo quanto prescritto al capo trasporti e salva diversa inderogabile norma di legge.

GARANZIA
Riconosciamo dalla data di consegna del prodotto il periodo di garanzia di 5 anni. La garanzia è limitata alla riparazione o sostituzione a nostra discrezione del prodotto accertato difettoso, esclusa ogni altra nostra obbligazione.
La sostituzione del prodotto avrà luogo franco nostro stabilimento di Maggiora. La garanzia non copre danni derivanti da negligenza o dolo ovvero da cause di forza maggiore.

La sostituzione o la riparazione della merce viziata potrà aver luogo solamente previa riconsegna franco nostro stabilimento di Maggiora degli esemplari contestati.

PAGAMENTI
I pagamenti dovranno essere trasmessi unicamente alla nostra sede.
Il mancato o ritardato pagamento anche parziale di una sola fattura o scadenza ci autorizza a sospendere l’esecuzione delle forniture incorso e al rifiuto di evasione di qualsivoglia ordine salvo il risarcimento del danno da noi subito.
L’esistenza di contestazioni sulle forniture non legittima alla sospensione o ritardo nei pagamenti.
L’inosservanza dei termini di pagamento comporterà l’addebito degli interessi di mora al tasso di cui al D.LGS. 231/02 con decorrenza dalla data di messa in mora, salva diversa nostra precisazione scritta.
Le merci restano di nostra proprietà fino all’integrale pagamento del relativo prezzo (art.li 1523- 1526 cod civ. ).
GIURISDIZIONE E LEGGE APPLICABILE
I rapporti commerciali con la nostra azienda sono regolati dalla legge italiana ovvero dalle prevalenti convenzioni internazionali ed ogni eventuale controversia sarà soggetta in via esclusiva alla giurisdizione del giudice italiano.

after receipt of the goods, except for the complaints made to the forwarding agent or except for rules binding by the law.

WARRANTY
We acknowledge a warranty period of 5 years after delivery date of the product. The warranty is limited to repair or replacement after we have decided the damages of the product, except for any other bond.
The replacement of the product will take place ex-factory in Maggiora.
The warranty doesn’t cover damages deriving from negligence or criminal intent or to circumstances beyond our control.
The replacement or the repair of the damaged goods can take place only after return ex-factory in Maggiora of the notified items.
PAYMENTS
Payments should be carried out to our head office only.
The missed or delayed payment, even partially of a single invoice or deadline, authorizes us to suspend the execution of the current supplies and the refusal to carry out whatever order, except for the restitution of the damages we were subject to.

The existence of notifications regarding supplies doesn’t allow suspension or delay in payments.
The non-observance of the payments terms will involve the charge of interests on delayed payments at a rate according to D.LGS. 231/02, starting from the date of interests except, for our written specifications.
The goods will be of our property till the complete payment of the related article (articles 1523- 1526 civil code).
JURISDICTION AND ENFORCEABLE LAWS.
The commercial relationships with our company have been regulated by the Italian law as well as by the prevalent international agreements and each possible controversy will be subject exclusively to the jurisdiction of the Italian judge.

## LES CONDITIONS GÉNÉRALES DE VENTE

### LA LISTE DES PRIX

Les prix indiqués sont exprimés en Euro au net de la TVA et ils s’entendent pour la marchandise rendue franco notre usine de MAGGIORA et ils sont ceux en vigueur à la date de la commande sauf notre différente offre écrite qui prévale sur cette condition générale.

### L'ACCEPTATION

Sauf une dérogation écrite préventive que nous avons écrit et souscrit, toutes les commandes s’entendent acceptées aux conditions générales de vente en vigueur, et si elles sont parvenues aux agents, elles seront pour nous liées par des engagements précis seulement à partir de notre approbation.

### LES TERMES DE LIVRAISON

Les termes de livraison s’entendent toujours indicatifs et péremptoires, aussi en dérogation ou une explication quelconque contenue dans les commandes ou dans les confirmations de commande qui proviennent du client. Les retards de la livraison ne donneront pas le droit au client d’annuler ou de réduire la commande ni à une quelconque demande de débit ou d’une amende de quelque sorte. Les termes sont calculés en jours de travail au net des suspensions déterminées par un cas imprévu, de force majeure ou de causes qui se réfèrent au client.

### LES PRODUITS

Nos produits sont projetés, fabriqués et essayés dans le respect des normes suivantes:

- pour la robinetterie traditionnelle UNI EN 200.
- pour les mélangeurs mono-commande UNI EN 817.

### LES TRANSPORTS

La marchandise voyage au risque et péril de l’acheteur, même si elle est expédiée franco destination. Au destinataire, même diffèrent de l’acheteur, il ressort de la peine de la décadence de la vérification de la marchandise, du nombre de colis, de l’état de l’emballage au moment du retrait ainsi que de l’expression des réserves et des contestations au transporteur et à l’expéditionnaire. De différentes conditions devront résulter par un acte souscrit par nous sous peine de nullité.

### LES TOLÉRANCES

L’échantillonnage des finissages est indicatif et nous ne donnons pas de garantie d’uniformité de couleur entre les différentes parties. L’attribution des commandes indique l’acceptation des tolérances de la différence de couleurs.

Nous pouvons modifier les caractéristiques techniques et constructives des produits, avec la seule limite de la réduction des fonctions garanties au produit.

### LES RÉCLAMATIONS

Les réclamations de tout genre devront parvenir exclusivement à notre société

# ALLGEMEINE VERKAUFSBEDINGUNGEN

### PREISLISTE

Die angegebenen Preise sind in Euro und nach Abzug der Mehrwertsteuer in Höhe von ausgedrückt und verstehen sich für frei unserer Niederlassung in MAGGIORA.

Diese gelten am Bestelldatum, unter Vorbehalt eines anderweitigen schriftlichen Angebotes unsererseits, welches über die vorliegenden, allgemeinen Verkaufsbedingungen vorherrscht.

### ANNAHME

Außer bei einer vorausgehenden, von uns stammenden und unterschriebenen schriftlichen Abweichung, verstehen sich alle Bestellungen zu den gültigen, allgemeinen Verkaufsbedingungen angenommen und, wenn sie uns über Vertreter erreicht haben sind diese für uns nur bis zum Ablauf unserer spezifischen Annahme bindend.

### LIEFERBEDINGUNGEN

Die Lieferbedingungen verstehen sich immer als richtungsweisend und nie endgültig, auch in Abweichung irgendeiner anderen, in den Bestellungen enthaltener Präzisierung, oder besser gesagt in den Auftragsbestätigungen seitens der Kunden.

Lieferverzögerungen verleihen dem Kunden kein Recht die Bestellung zu annullieren oder zu vermindern, noch Anrecht auf irgendein Lastschriftgesuch oder Strafe irgendeiner Art. Die Liefertermine sind als Arbeitstage berechnet, unter Abzug der Unterbrechungen, verursacht durch Zufall, höhere Gewalt oder irgendwelche Gründe, die dem Kunden anzurechnen sind.

### PRODUKTE

Unsere Produkte sind unter Berücksichtigung der folgenden Vorschriften entwickelt, hergestellt und abgenommen worden:
- die traditionellen Armaturen UNI EN 200.
- die Einhebel-Mischbatterien UNI EN 817.

### TRANSPORTE

Die Ware, auch wenn sie frei Bestimmungsort verschickt wird, wird sie auf Risiko und Gefahr des Erwerbers transportiert. Der Empfänger, auch wenn dieser nicht der Erwerber ist, ist unter Verwirkungsstrafe dafür zuständig, die Ware, die Anzahl der Warenposten, den Zustand der

car les agents ne sont pas légitimés à les recevoir ainsi qu’aucun autre sujet extérieur à notre direction des ventes. Les réclamations sur les biens fournis seront proposées à la seule condition que le paiement tout entier soit advenu. Les réclamations devront parvenir en forme écrite et détaillée sous peine d’inadmissibilité dans les 8 (huit) jours de la réception de la marchandise, sauf tout ce qui a décrit au chef des transports et sauf une différente norme de loi indéréglable.

### LA GARANTIE

Nous reconnaissons une période de garantie de 5 ans de la date de la livraison du produit.

La garantie est limitée à la réparation ou à la substitution à notre discrétion du produit que nous estimons défectueux, exclue notre obligation à la substitution. La substitution du produit aura lieu franco notre usine de Maggiora. La garantie ne couvre pas les dégâts qui dérivent de la négligence ou de dol ou des causes de force majeure.

La substitution ou la réparation de la marchandise abîmée pourra avoir lieu seulement à un préalable livraison des exemplaires contestés.

### LES PAYEMENTS

Les paiements doivent être transmis seulement à notre siège. Le payement manqué ou retardé et aussi partiel d’une seule facture ou d’une échéance nous autorise à suspendre l’exécution des fournitures en cours et au refus d’évasion d’une commande quelconque sauf le dédommagement du dégât subi par nous.

L’existence de contestations sur les fournitures, elle n’est pas légitime à la suspension ou aux retards dans les payements.

L’inobservance des termes de payement comportera le débit des intérêts d’amende moratoire au taux du D.LGS. 231/02 à partir de la date de la mise en amende moratoire, sauf notre explication écrite.

Les marchandises sont de notre propriété jusqu’au payement entier du prix relatif (selon les articles 1523- 1526 du code civil).

### LA JURIDICTION ET LA LOI APPLICABLE

Les rapports commerciaux avec notre usine sont réglés par la loi italienne ou par les conventions internationales et toute controverse sera sujette en voie exclusive à la juridiction du juge italien.

<p>Verpackung bei der Entgegennahme zu kontrollieren, sowie dem Frachtführer oder Spediteur gegenüber eventuelle Vorbehalte oder Beanstandungen auszu- drücken. Eventuell abweichende Bedingungen, müssen sich aus einem von uns unterschriebenem Dokument ergeben, da sie sonst nichtig sind.</p>
<p><b>TOLERANZEN</b> Die Beschaffenheit der Muster ist rein indikativ und es wird keine Garantie für die Farbgleichheit zwischen unterschiedlichen Partien gegeben. Die Erteilung von Bestellungen bedeutet die Annahme der Farbabweichungen. Es liegt in unserer Macht, technische oder bauliche Eigenschaften der Produkte abzuändern, mit der einzigen Einschränkung, dass diese nicht die, für das Pro- dukt garantierte Funktionalität vermindern.</p>
<p><b>REKLAMATIONEN</b> Reklamationen jeglicher Art müssen ausschließlic<span>h</span> unserer Gesellschaft zukom- men, insofern weder die Vertreter dazu berechtigt sind, diese entgegenzuneh- men, noch irgendjemand anderer, der nicht unserer Verkaufsleitung angehört. Reklamationen hinsichtlich der gelieferten Waren sind nur unter der Bedingung gültig vorgebracht, wenn der Gesamtbetrag für diese in voller Höhe vorausgezahlt ist. Die Reklamationen müssen uns in schriftlicher und detaillierter Form innerhalb von 8 Tagen ab Warenerhalt erreichen, da sie sonst unzulässig sind, unter Vorbehalt der Vorschriften unter dem Absatz Transporte und unter Vorbehalt anderslautender unabdingbarer gesetzlicher Bestimmungen.</p>

### GARANTIE

Wir gewährleisten ab Lieferdatum des Produktes eine 5-jaerige Garantiezeit. Die Garantie beschränkt sich auf die Reparatur oder das Austauschen des, nach unserem Ermessen als defekt festgestelltes Produkt, ausgeschlossen jeder anderen unserer Verpflichtung. Das Austauschen des Produktes vollzieht sich frei unserer Niederlassung in Maggiora. Die Garantie deckt keine Schäden, die auf Fahrlässigkeit oder Vorsatz, bzw. auf höhere Gewalt zurückzuführen sind. Das Austauschen oder die Repa- ratur der fehlerhaften Ware kann erst nach vorausgehender Rücklieferung der beanstandeten Produkte frei unserer Niederlassung in Maggiora durchgeführt werden.

### ZAHLUNGSBEDINGUNGEN

Die Überweisungen müssen einzig und allein an unsere Niederlassung durch- geführt werden. Eine fehlende oder verspätete Zahlung, wenn auch nur teilweise, einer einzigen Rechnung oder hinsichtlich der Fälligkeit berechtigt uns, die Durchführung der laufenden Lieferungen einzustellen und zur Verweigerung der Erledigung jeglicher Bestellung, unter Vorbehalt einer Entschädigung hinsichtlich des, von uns erlittenen Schaden
Das Vorhandensein von Beanstandungen hinsichtlich der Lieferungen berechtigt nicht zur Einstellung oder Verzögerung von Zahlungen. Die Nichtbeachtung der Zahlungsfristen führt zur Lastschrift bezüglich der Verzu- gszinsen gemäß Ermächtigungsgesetz 231/02 ab dem Datum der in Verzugset-

# CONDICIONES GENERALES DE VENTA

### LISTA DE PRECIOS

Los precios indicados se expresan en euros, al neto del de IVA, y se consideran para la mercancia puesta en nuestro establecimiento de MAGGIORA; son los precios vigentes a la fecha del pedido, salvo diversa oferta nuestra escrita, que prevalecerá sobre la presente condición general.

### ACEPTACIÓN

Salvo preventiva derogación nuestra, escrita y firmada, todos los pedidos se consideraran aceptados en las condiciones generales de venta vigentes y, si han sido transmitidos a los agentes, serán vinculantes para nosotros solamente a partir de nuestra específica aprobación.

### TÉRMINOS DE ENTREGA

Los términos de entrega se consideran siempre indicativos y perentorios, incluso en derogación de toda diversa indicación contenida en los pedidos, o sea, en las confirmaciones de pedido provenientes del cliente. Retrasos en la entrega no dan derecho al cliente a anular o reducir el pedido, ni a solicitar adeudo o sanción alguna. Los plazos se calculan en días laborales al neto de las suspensiones determinadas por caso fortuito, fuerza mayor o causas de todos modos referibles al cliente.

### PRODUCTOS

Nuestros productos se proyectan, fabrican y ensayan en concordancia con las siguientes normas:
- para la grifería tradicional, UNI EN 200.
- para los mezcladores monomando, UNI EN 817.

### TRANSPORTE

La mercancia, incluso cuando es enviada franco destinación, viaja a riesgo y pe- ligro del comprador. El destinatario aun cuando es diferente del comprador debe, pena la caducidad, verificar la mercancia, el número de fardos, el estado del em- balaje en el momento de la entrega, así como expresar las eventuales reservas y reclamaciones al vector o al transportista. Eventuales diferentes condiciones deberán resultar en documento firmado por nosotros, pena la nulidad.

### TOLERANCIAS

El muestrario de acabados es puramente indicativo y no se entrega garantía de uniformidad de coloración entre diversas partidas. El retiro de los pedidos indica aceptación de las tolerancias inherentes a la diferencia de color. Nos reserva- mos la facultad de modificar las características técnicas y constructivas de los productos, con el solo límite de la reducción de las funcionalidades garantizadas al producto.

### RECLAMACIONES

# PULIZIA / CLEAN

Si raccomanda di pulire le superfici cromate, dorate e colorate con acqua e sapo- ne usando un pammo morbido.

It is recommended to clean chrome plated, gold and coloured surfaces with soap and water by using a soft cloth.

Pour l’entretien de toute notre robinetterie dans les solutions chromées, dorées et colorées, nous recommandons d’utiliser uniquement de l’eau et du savon avec un chiffon souple.

Wir empfehlen die verchromte, vergoldete und farbige Oberfläche mit Wasser, Seife und einem weichen Tuch zu reinigen.

Se recomienda limpiar las superficies cromadas, doradas y coloreadas con agua y jabón utilizando un paño suave.

zung, unter Vorbehalt anderslautender schriftlicher Präzision unsererseits. Die Ware bleiben bis zur vollständigen Zahlung des jeweiligen Preises unser Eigentum (Art. 1523- 1526 BGB ).

### GERICHTSBARKEIT UND ANWENDBARE GESETZE

Die Geschäftsverhältnisse mit unserem Unternehmen unterliegen dem italieni- schen Gesetz, bzw. den vorherrschenden internationalen Abkommen und jegliche Streitfrage unterliegt ausschließlich der Gerichtsbarkeit des italienischen Richters.

Reclamaciones de cualquier naturaleza deberán enviarse exclusivamente a nues- tra sociedad; no serán legítimas aquellas recibidas por los agentes ni cualquier otro sujeto externo a nuestra dirección de ventas.

Las reclamaciones sobre los bienes proveídos serán válidas a condición de que se haya realizado su preventivo e integral pago.

Las reclamaciones deberán entregarse por escrito y en forma detallada, pena la no admisibilidad, en los 8 días siguientes a la recepción de la mercancia, salvo las prescripciones del jefe de transporte y salvo diversa inderogable norma de ley.

### GARANTÍA

Reconocemos, a partir de la fecha de entrega del producto, el período de garan- tía de 5 anos.

La garantía se limita a la reparación o sustitución, a nuestra discreción, del pro- ducto defectuoso, excluyendo cualquier otra nuestra obligación.

La sustitución del producto tendrá lugar en nuestro establecimiento de Maggiora. La garantía no cubre daños derivados de negligencia o dolo, o sea, de causas de fuerza mayor.

La sustitución o la reparación de la mercancia imperfecta podrá realizarse sola- mente previa devolución en nuestro establecimiento de Maggiora de las unidades reclamadas.

### PAGOS

Los pagos deberán ser transmitidos únicamente a nuestra sede. La falta o el retraso del pago incluso parcial de una sola factura o vencimiento, nos autoriza a suspender la realización de las provisiones en curso y a rechazar la entrega de cualquier otro pedido, salvo el resarcimiento del daño sufrido. La existencia de reclamaciones acerca de las provisiones no legitima la suspen- sión o el atraso en los pagos.

La inobservancia de los términos de pago comportará el adeudo de los intereses de mora con la tasa indicada por el Dec. Leg. 231/02 con efecto a partir de la fecha de declaración en mora, salvo nuestra diversa indicación escrita. Las mercancías son de nuestra propiedad hasta el pago integral del correspon- diente precio (Art. 1523 - 1526 del Código Civil).

### JURISDICCIÓN Y LEY APLICABLE

Las relaciones comerciales con nuestra empresa son reguladas por la ley italia- na, o sea por las convenciones internacionales que prevalecen, y toda eventual controversia estará sujeta en vía exclusiva a la jurisdicción del juez italiano.

<b>5</b>
anni di garanzia years guarantee ans de garantie jahre garantie años de garantía





Le fotografie e i disegni sono puramente indicativi / The pictures and the drawings are only indicative

Webert Industry srl  
Via Maggiate 69/C  
Borgomanero / NO / Italy  
+39 0322 840771  
info@webert.it

 webert\_official

 Webert